

Thank you for purchasing Samwontech production. Please use after read instruction manual for safety. Free to contact to our sales Div. for Production Inquiry and After Service.
 Tel : +82-32-326-9120 FAX : 032-326-9119
 http://www.samwontech.com E-mail : webmaster@samwontech.com

Safety Guide

The following safety symbols are used in this manual.

- CAUTION** If this symbol is marked on the product, the operator must investigate the explanation given in this manual to protect injury or death to personnel or damage to instrument.
- Be sure to operate the controller installed on a panel to prevent electric shock.
 - Keep the input circuit wiring as far as possible away from power and ground circuit.
 - Do not mount front panel facing downward.
 - To prevent electric shock, be sure to turn off and the source circuit breaker before wiring.
 - The power consumptions are 100-240VAC, 50/60Hz, 10VAmx(24VDC/17VAC) and operate without power switching in advance.
 - No work in wet hands (it caused electric shock)
 - Refer the way of grounding connection, however, keep away from grounding to Gas pipe, water pipe, lightning rod etc.
 - No magnetic disturbances are caused.

Control Keys and Display

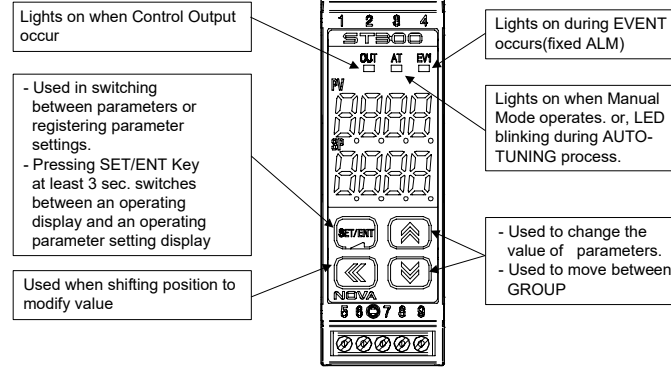

Type of Input Sensor

*display range : -5% ~ +105%

No.	TYPE	Temp.Range(°C)	Temp.Range(°F)	Group	DISP
1	K1	-200 ~ 1370	-300 ~ 2500	T/C	TC.K1
2	K2	-199.9 ~ 999.9	0 ~ 2300		TC.K2
3	J	-199.9 ~ 999.9	-300 ~ 2300		TC.J
4	E	-199.9 ~ 999.9	-300 ~ 1800		TC.E
5	T	-199.9 ~ 400.0	-300 ~ 750		TC.T
6	R	0 ~ 1700	32 ~ 3100		TC.R
7	B	0 ~ 1800	32 ~ 3300		TC.B
8	S	0 ~ 1700	32 ~ 3100		TC.S
9	L	-199.9 ~ 900.0	-300 ~ 1600		TC.L
10	N	-200 ~ 1300	-300 ~ 2400		TC.N
11	U	-199.9 ~ 400.0	-300 ~ 750		TC.U
12	W	0 ~ 2300	32 ~ 4200		TC.W
13	Platinel II	0 ~ 1390	32 ~ 2500		TC.PL
14	PIA	-199.9 ~ 850.0	-300 ~ 1560	RTD	PTA
15	PB	-199.9 ~ 500.0	-199.9 ~ 999.9		PTB
16	PTC	-150.0 ~ 150.0	-199.9 ~ 300.0		PTC
17	JPIA	-199.9 ~ 500.0	-199.9 ~ 999.9		JPTA
18	JPIB	-150.0 ~ 150.0	-199.9 ~ 300.0		JPTB
19	0.4~2.0V	0.400 ~ 2.000V			DCV
20	1~5V	1 ~ 5V		5V	
21	0~10V	0 ~ 10V		10V	
22	-10~20mV	-10 ~ 20mV		mV	20M
23	0~100mV	0 ~ 100mV			100M

Parameter Map

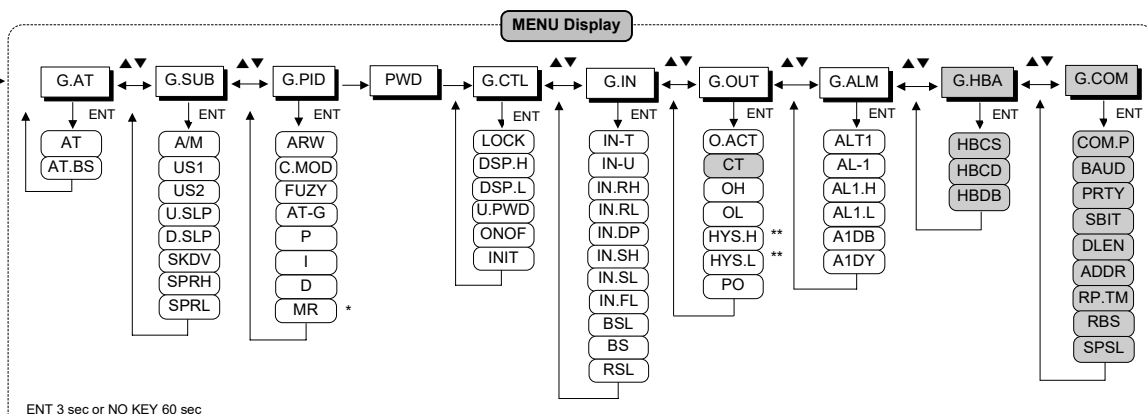
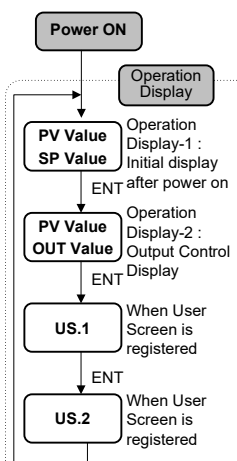

OPTION

I=0

ON/OFF Operation

* Operation in Power ON : Start in Operation MODE before Power OFF

· AUTO Operation MODE : Start Control from PO

Type & Suffix Code

Model	Suffix Code	Description	Remark
ST300	-□□/□□	Digital Controller	
Control Output	S	SSR	
	A	SCR(4~20mA)	
	R	RELAY	
Power	0	100~240V AC	
	1	24V DC	
Options	/RS	RS485	
	/HBA	Heater Break Alarm	

Specification

- PV/SP Data Display : each 4 digits
- Sampling Time : 250ms
- Indication Accuracy : ±0.2% of FS
- Running Mode : AUTO / MAN
- Control Loops and Mode : Single-Loop Control
- Number of Setpoint(SP) : 1SP(1 Zone PID)
- Communication Protocols : PC-Link, MODBUS(ASCII, RTU), SYNC Master, Slave
- Power Supply and Consumption : 100 ~ 240V AC, 50 ~ 60Hz / Max 10VA below 24V DC(17V AC) / Max 10VA below

Sensor

- PV Input : Universal Input(1 Point)
- Type of Input
T/C : K, J, E, T, R, B, S, L, N, U, W, Platinel II
RTD : Pt100, JPt100
DCV : -10 ~ 20mV, 0 ~ 100mV, 0.4 ~ 2.0V DC, 1 ~ 5V DC, 0 ~ 10V DC (4 ~ 20mA, 0 ~ 20mA, with external 250Ω, 500Ω)

Output

- Control Output : 1 Point
- Time-proportional PID : Relay, SSR(V-Pulse)
- Continuous PID : SCR(4 ~ 20mA DC)

Alarm

- Alarm Capacity : 1 Point
- Alarm Type : 21 types(High/Low Temp Limit, Deviation Limit etc)

HBA

- CT Spec : use CTL-6-S or 800:1 CT

Safety & EMC

- Safety : EN61010-1, UL61010C-1, CAN/CSA C22.2 No.10101-92, Category II
- EMC : EMI(Emission) - EN61326, ClassA
EMS(Immunity) - EN61326

Type of Alarm

No.	Type	Output Direct For Rev	Standby Off On	Display Data	No.	Type	Output Direct For Rev	Standby Off On	Display Data
1	Absolute-Value Upper-Limit Alarm	○	○	AH.F	11	Absolute-Value Upper-Limit Alarm	○	○	AH.FS
2	Absolute-Value Lower-Limit Alarm	○	○	AL.F	12	Absolute-Value Lower-Limit Alarm	○	○	AL.FS
3	Upper-Limit Alarm of Deviation	○	○	DH.F	13	Upper-Limit Alarm of Deviation	○	○	DH.FS
4	Lower-Limit Alarm of Deviation	○	○	DL.F	14	Lower-Limit Alarm of Deviation	○	○	DL.FS
5	Upper-Limit Alarm of Deviation	○	○	DH.R	15	Upper-Limit Alarm of Deviation	○	○	DH.RS
6	Lower-Limit Alarm of Deviation	○	○	DL.R	16	Lower-Limit Alarm of Deviation	○	○	DL.RS
7	Upper-and-Lower-Limit alarm of Deviation	○	○	DO.F	17	Upper-and-Lower-Limit alarm of Deviation	○	○	DO.FS
8	Upper-and-Lower-Limit Range of Deviation	○	○	DI.F	18	Upper-and-Lower-Limit Range of Deviation	○	○	DI.FS
9	Absolute-Value Upper-Limit Alarm	○	○	AH.R	19	Absolute-Value Upper-Limit Alarm	○	○	AH.RS
10	Absolute-Value Lower-Limit Alarm	○	○	AL.R	20	Absolute-Value Lower-Limit Alarm	○	○	AL.RS
21	Soak	○	○	Soak	22	Lower-Limit Alarm of HBA	○	○	HBA

Alarm Operation

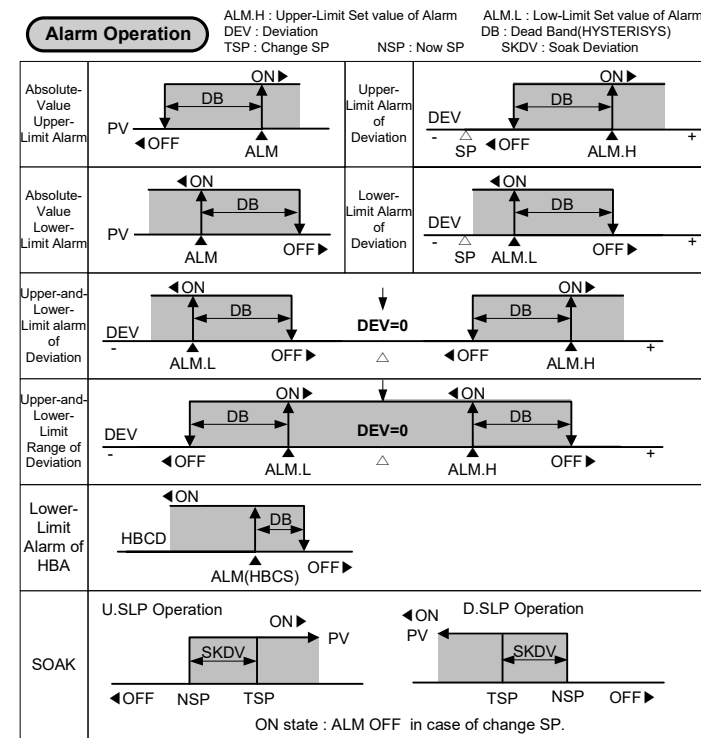

PARAMETER Table

AT GROUP

Symbol	Parameter	Setting Range	Unit	Initial	Remark
AT	Auto Tuning	OFF, ON	ABS	OFF	AUTO Operation
AT.BS	Auto Tuning Bias	EUS(-10.0 ~ 10.0%)	EUS	EUS(0.0%)	Always

⊙ AT GROUP is skipped in ON/OFF MODE operation.

SUB GROUP

Symbol	Parameter	Setting Range	Unit	Initial	Remark
A/M	AUTO, MAN	AUTO, MAN	ABS	AUTO	Always
US1	User Screen	OFF, D-Register Number(1~1299)	ABS	OFF	Always
US2	User Screen	OFF, D-Register Number(1~1299)	ABS	OFF	Always
U.SLP	Up Slope	OFF(0), EUS(0.0%+1digit~100.0%)/min	EUS	OFF(0)	Always
D.SLP	Down Slope	OFF(0), EUS(0.0%+1digit~100.0%)/min	EUS	OFF(0)	Always
SKDV	Soak Deviation	EUS(0.0 ~ 10.0%)	EUS	EUS(0.0%)	When select ALM=SOAK
SPRH	Set Point Range High	EU(0.0 ~ 100.0%)	EU	EU(100.0%)	Always
SPRL	Set Point Range Low	EU(0.0 ~ 100.0%)	EU	EU(0.0%)	Always

P.I.D GROUP

Symbol	Parameter	Setting Range	Unit	Initial	Remark
ARW	Anti-Reset Wind-Up Select	Auto(0.0) ~ 200.0%	%	100.0%	Always
C.MOD	Control Mode	D.DV, D.PV	ABS	D.PV	Always
FUZY	Fuzzy	OFF, ON	ABS	OFF	Always
AT-G	AT Gain	0.1 ~ 10.0	ABS	1.0	AUTO Operation
P	Proportional Band	0.1 ~ 999.9%	%	10.0%	Always
I	Integral Time	OFF, 1 ~ 6000 sec	sec	120 sec	Always
D	Derivative Time	OFF, 1 ~ 6000 sec	sec	30 sec	Always
MR	Manual Reset	-5.0 ~ 105.0%	%	50.0%	I=0

⊙ P.I.D GROUP is skipped in ON/OFF MODE operation.

CTL GROUP

Symbol	Parameter	Setting Range	Unit	Initial	Remark
LOCK	Key Lock	OFF, ON(No Editing)	ABS	OFF	Always
DSP.H	Display High Limit	EU(-5.0 ~ 105.0%) ; However, DSP.L < DSP.H	EU	EU(105.0%)	Always
DSP.L	Display Low Limit	EU(-5.0 ~ 105.0%) ; However, DSP.L < DSP.H	EU	EU(-5.0%)	Always
U.PWD	User Password	0 ~ 9999	ABS	0	Always
ONOF	ON/OFF MODE	OFF, ON	ABS	OFF	Always
INIT	Parameter Initialization	OFF, ON	ABS	OFF	Always

IN GROUP

Symbol	Parameter	Setting Range	Unit	Initial	Remark
IN-T	Input Type	refer to "Type of Input Sensor"	ABS	TC.K1	Always
IN-U	Display Range	°C, °F	ABS	°C	T/C, RTD
IN.RH	Max. Value of Measurement Range	refer to "Type of Input Sensor"	EU	EU(100%)	Always
IN.RL	Min. Value of Measurement Range	However, INRH > INRL	EU	EU(0.0%)	Always
IN.DP	Decimal Point Position	0 ~ 3	ABS	1	mV, V
IN.SH	Max Value of Input Scale	Within -1999 ~ 9999 however, INSH > INSL	EU	100.0	mV, V
IN.SL	Min Value of Input Scale	The Decimal Point Position is relay on the value of IN.DP	EU	0.0	mV, V
IN.FL	PV Filter	OFF, 1 ~ 120	sec	OFF	Always
BSL	BOU SEL	OFF, UP, DOWN	ABS	0	UP (DCV=OFF) Always
BS	Bias Value	EUS(-100.0 ~ 100.0%)	ABS	0	Always
RSL	RJC SEL	TC, TC.RJ, RJC	ABS	TC.RJ	T/C

OUT GROUP

Symbol	Parameter	Setting Range	Unit	Initial	Remark
O.ACT	Reverse and Forward	REV, FWD	ABS	REV	Always
CT	Cycle Time	1 ~ 300 sec	sec	2 sec	Output=SSR, RLY
OH	High-Limit value of Output	OL + 1Digit ~ 105.0% (However, OH>OL)	%	100.0%	Always(ON/OFF Mode: SKIP)
OL	Low-Limit value of Output	-5.0% ~ OH - 1Digit (However, OH>OL)	%	0.0%	Always(ON/OFF Mode: SKIP)
HYS.H	HYSTERISYS HIGH	EUS(0.0 ~ 10.0%)	EUS	EUS(0.5%)	ON/OFF Mode
HYS.L	HYSTERISYS LOW	EUS(0.0 ~ 10.0%)	EUS	EUS(0.5%)	ON/OFF Mode
PO	Preset Out	-5.0 ~ 105.0%	%	0.0%	Always

ALARM GROUP

Symbol	Parameter	Setting Range	Unit	Initial	Remark
ALT1	Alarm Type 1	refer to "Type of Alarm"	ABS	AH.F	Always
AL-1	Set value of ALT1	EU(-100.0 ~ 100.0%)	EU	EU(100.0%)	Not Deviation Alarm
AL1.H	Upper-Limit Set value of ALT1	EUS(-100.0 ~ 100.0%)	EUS	EUS(0.0%)	Deviation Operation
AL1.L	Low-Limit Set value of ALT1	EUS(-100.0 ~ 100.0%)	EUS	EUS(0.0%)	Deviation Operation
A1DB	Alarm 1 Hys	EUS(0.0 ~ 100.0%)	EUS	EUS(0.5%)	Always
A1DY	Alarm 1 Operation Delay Time	0.00~99.59(MM.SS) ALT1-HH:MM in case of Soak	TIME	0.00	Always

HBA GROUP

Symbol	Parameter	Setting Range	Unit	Initial	Remark
HBCS	Heater Break Current Set	OFF, 1 ~ 50A	ABS	OFF	Option
HBCD	Heater Break Current Display	DISPLAY ONLY	ABS	INRH	Option
HBDB	Heater Break Current DB	0 ~ 10A	ABS	1	Option

COMM GROUP

Symbol	Parameter	Setting Range	Unit	Initial	Remark
COM.P	Communication Protocol	PCC0, PCC1, MODBUS ASCII, MODBUS RTU, SYNC-Master, SYNC-Slave	ABS	PCC0	Option
BAUD	Baud Rate	600, 1200, 2400, 4800, 9600, 19.2K	ABS	9600	Option
PRTY	Parity	None, Even, Odd	ABS	None	Option
SBIT	Stop Bit	1, 2	ABS	1	Option
DLEN	Data Length	7,8(SKIP in MODBUS)	ABS	8	Option
ADDR	Address	1 ~ 99(Max 31 can connect)	ABS	1	Option
RP.TM	Response Time	0 ~ 10(x10ms)	ABS	1	Option
RBS	Remote Bias	EUS(-100.0 ~ 100.0%)	EUS	EUS(0.0%)	SYNC-Slave
SPSL	SP SELECT	RSP, LSP	ABS	LSP	Option

Power Cable Connection

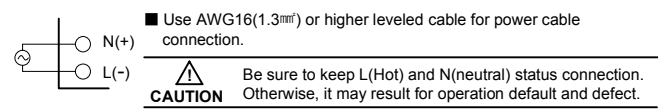

ANALOG INPUT Connection

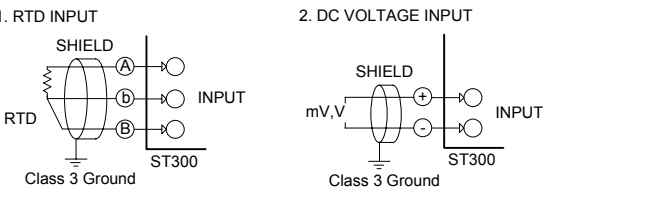

DC CURRENT INPUT

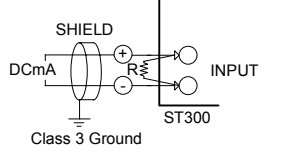

ANALOG OUTPUT Connection

CAUTION To prevent electric shock, be sure to turn off the ST300 Controller and the source circuit breaker before wiring.

1. SSR / SCR

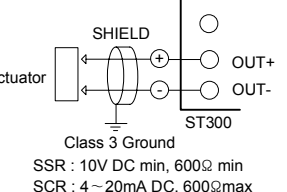

CAUTION To prevent electric shock, be sure to turn off the ST300 controller and the source circuit breaker before connection/disconnection of the actuator as well as wiring.

Terminal Arrangement and External wiring

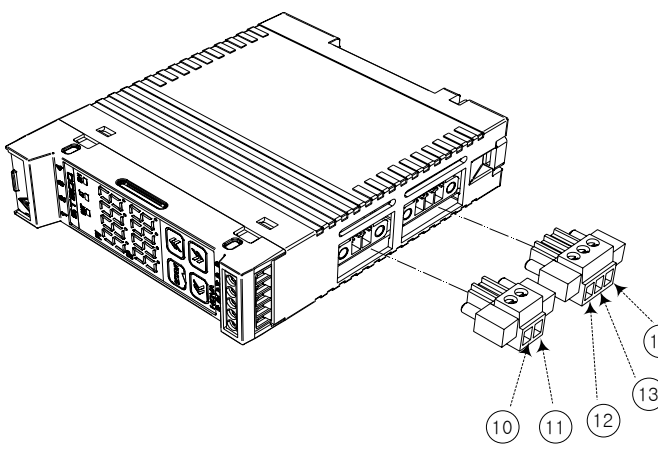
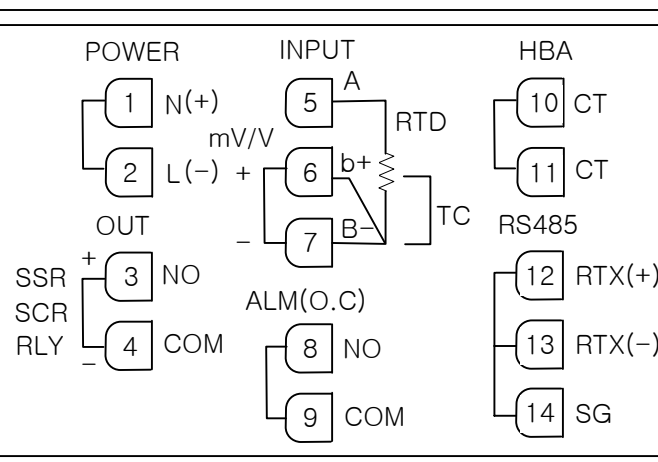

RELAY Connection

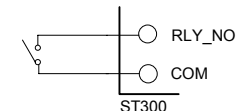

CAUTION To protect electric shock, be sure to turn off the ST300 controller and the source circuit breaker before wiring.

Use an Auxiliary RELAY

When using an auxiliary relay or inductance load (L) such as solenoid, be sure to insert a CR filter(for AC) or diode (for DC) in parallel as a surge-suppressor circuit to reject sparks, preventing malfunction or damage.

Recommended CR FILTER

- ▶ Seong Ho Electronics : BSE104R120 25V (0.1μ+120Ω)
- ▶ HANA PARTS CO. : HN2EAC
- ▶ Songmi Electric Co.,Ltd. : CR UNIT 953, 955 etc
- ▶ Jiwol Electric Co.,Ltd. : SKV, SKVB etc
- ▶ Shinyoung Communications Co.,Ltd. : CR-CFS, CR-U etc

1. In case of DC RELAY

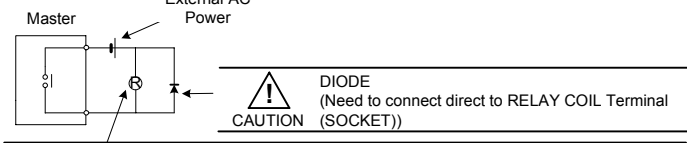

CAUTION RELAY (Rating Specification of RELAY COIL should be used lower than the Contact Rating of Controller)

2. In case of AC RELAY

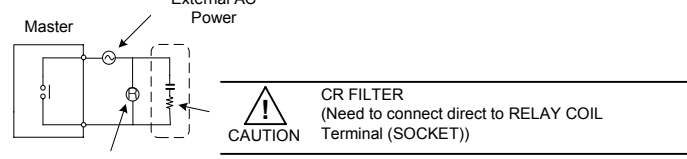

CAUTION RELAY (Rating Specification of RELAY COIL should be used lower than the Contact Rating of Controller)

DO Connection

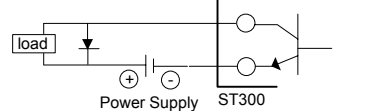

Communication Wiring (RS485)

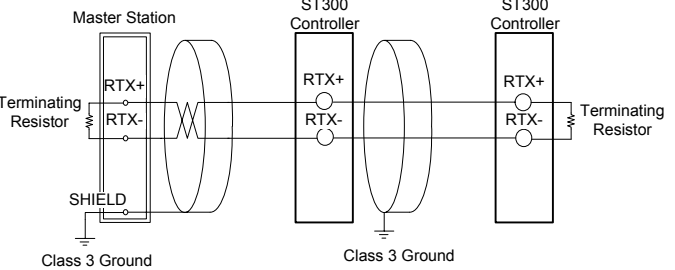

Up to 31 slave controllers(ST300 instruments equipped with communication option) can be multidrop-connected.

Be sure to connect terminating resistors(220Ω, 1/4W) to slave and master controllers at communication-channel ends as shown above.

CAUTION To prevent electric shock, be sure to turn off the ST300 controller and source circuit breaker before wiring.

Power Cable Specification

Power Cable Specification(1,2 Terminal) : AWG16(1.3mm²)

Cable Specification

Cable Specification(3~9 Terminal) : AWG26-16(0.13mm² ~ 1.3mm²)

CAUTION Never touch the terminal in the rear panel to prevent electric shock when power is supplied to the controller, and Be sure to turn off the electric power before wiring. Bind the wires connected to the controller terminals neatly together in order to prevent electromagnetic wave radiation.

Display Error and Correction

Display ERROR	ERROR Contents	Correction
E.SYS	EEPROM, DATA Loss	Ask repair
E.RJC	RJC SENSOR Failure	Ask repair
Flash Decimal point of SP	Communication Failure	Comm Cable CHECK
S.OPN	SENSOR Open	SENSOR CHECK
E.AT	AT Time Out (27h over)	PROCESS CHECK

Dimension

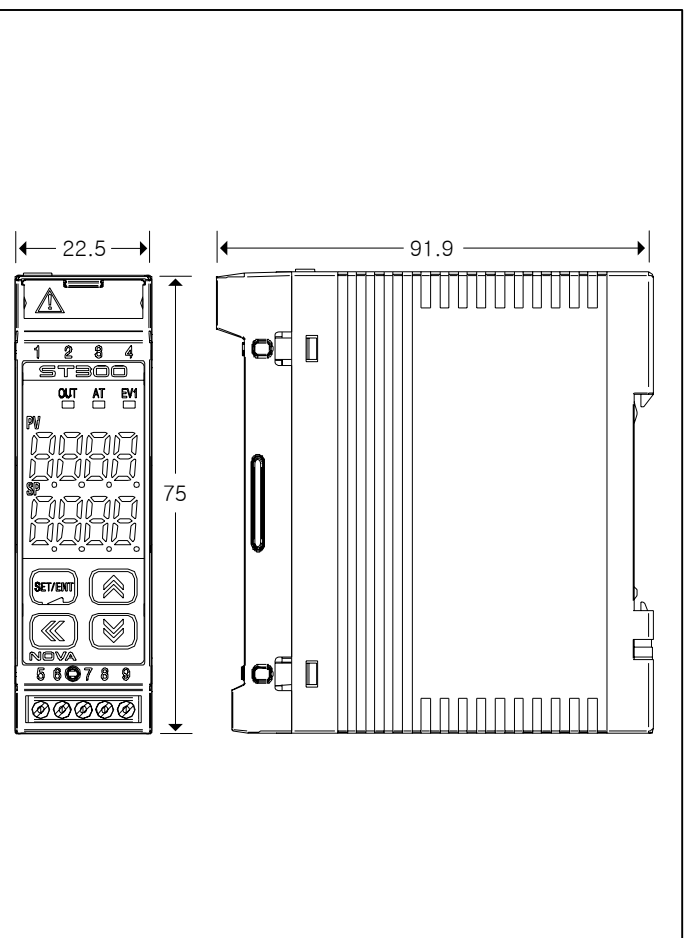

RAIL Installation

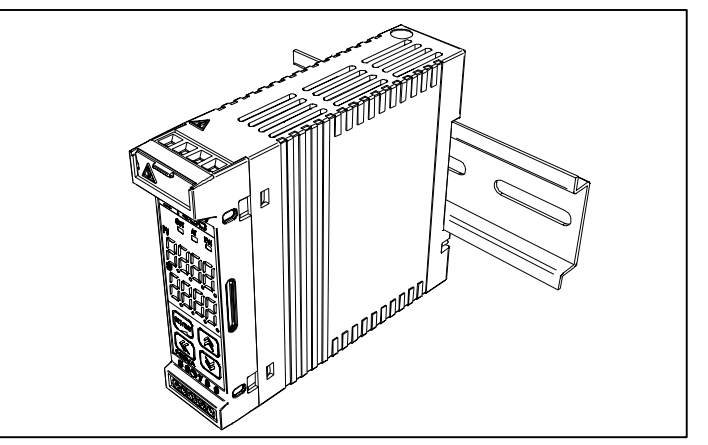

Assembly Method with Communication Function(Optional)

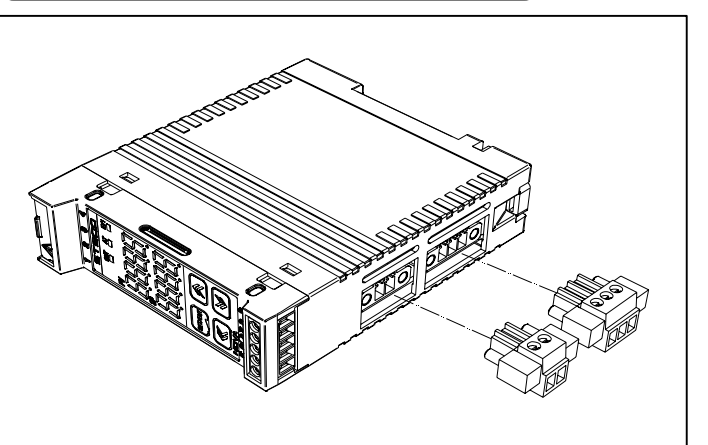

D-Register

NO	PROCESS	FUNCTION	CONTROL	HBA	ALARM	PID	IN/OUT
0	100	200	300	400	500	600	
0							
1	NPV		SP	HBCS	ALT1	ARW	IN-T
2	NSP			HBCD		FUZZY	IN-U
3			LOCK	HBDB		P	IN.RH
4			DSP.H			I	IN.RL
5		A/M	DSP.L			D	IN.DP
6	MVOUT				AL-1	MR	BS
7			ONOF			C.MOD	IN.SH
8			INIT				IN.SL
9							IN.FL
10							BSL
11			SPRH		AL1.H		O.ACT
12			SPRL				CT
13							OH
14	ALSTS						OL
15							HYS.H
16			U.SLP		AL1.L		HYS.L
17			D.SLP				PO
18			SKDV				RSL
19							
20							
21		AT			A1DB		
22		AT-G					
23		AT.BS					
24							
25							
26					A1DY		
27							
28							COM.P
29							BAUD
30							PRTY
31							SBIT
32							DLEN
33							ADDR
							RP.TM

NO	PROCESS	FUNCTION	CONTROL	HBA	ALARM	PID	IN/OUT
0	100	200	300	400	500	600	
34							
35							
36		US1					
37		US2					
38							
39							
40							
41							
42							
43							
44							
45							
46							
47							
48							
49							
50							
51							
52							
53							
54							
55							
56							
57							
58							
59							
60							
61							
62							
63							
64							
65							
66							
67							

NO	PROCESS	FUNCTION	CONTROL	HBA	ALARM	PID	IN/OUT
0	100	200	300	400	500	600	
68							RBS
69							SPSL
70							
71							
72							
73							
74							
75							
76							
77							
78							
79							
80							
81							
82							
83							
84							
85							
86							
87							
88							
89							
90							
91							
92							
93							
94							
95							
96							
97							
98							
99							

(* Thick Line : Read Only)