

Thank you for purchasing SamwonTech. Please use after read instruction for safety. Free to contact to our sales Div. for Production Inquiry and After Service.
Tel : +82-32-326-9120 FAX : 032-326-9119
http://www.samwontech.com E-mail : webmaster@samwontech.com

Safety Guide

The following safety symbols are used in this manual.

- CAUTION** If this symbol is marked on the product, the operator must investigate the explanation given in this manual to protect injury or death to personnel or damage to instrument.
- CAUTION**
1. Be sure to operate the controller installed on a panel to prevent electric shock.
 2. Keep the input circuit wiring as far as possible away from power and ground circuit.
 3. Do not mount front panel facing downward.
 4. To prevent electric shock, be sure to turn off and the source circuit breaker before wiring.
 5. The power consumptions are 100-240VAC, 50/60Hz, 10VAmax and operate without power switching in advance.
 6. No work in wet hands(it caused electric shock)
 7. Refer the way of grounding connection, however, keep away for grounding to Gas pipe, water pipe, lightning rod etc.
 8. No magnetic disturbances are caused.

Control Keys and Display

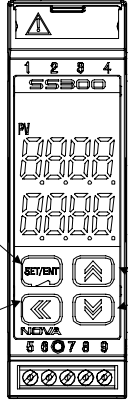

- Used in switching between parameters or registering parameter settings.
- Pressing SET/ENT Key at least 3 sec. switches between an operating display and an operating parameter setting display

Used when shifting position to modify value

- Used to change the value of parameters.
- Used to move between GROUP

Type & Suffix Code

Model	Suffix Code	Description	Remark
SS300	-□□/□□	Digital Signal Converter	
Retransmission Output	A	4~20mA	
	B	0~20mA	
	1	0~100mV	
	2	0~10V	
	3	0~5V	
Power	0	100~240V AC	
	1	24V DC	
Options	/RS	RS485	
	/4~20mA	4~20mA	
	/0~20mA	0~20mA	
	/0~100mV	0~100mV	
	/0~10V	0~10V	
	/0~5V	0~5V	
	/1~5V	1~5V	

PARAMETER Table

SUB GROUP

Symbol	Parameter	Setting Range	Unit	Initial	Remark
US1	User Screen	OFF, D-Register Number(1~1299)	ABS	OFF	Always
US2	User Screen	OFF, D-Register Number(1~1299)	ABS	OFF	Always

CTL GROUP

Symbol	Parameter	Setting Range	Unit	Initial	Remark
PV.LO	PV MIN.Value	EU(-5.0~105.0%) : Read Only	EU	EU(100.0%)	Always
PV.HI	PV MAX.Value	EU(-5.0~105.0%) : Read Only	EU	EU(0.0%)	Always
M.CLR	MIN MAX CLEAR	OFF, ON	ABS	OFF	Always
DSP.H	Display High Limit	EU(-5.0 ~ 105.0%) : However, DSP.L<DSP.H	EU	EU(105.0%)	Always
DSP.L	Display Low Limit	EU(-5.0 ~ 105.0%) : However, DSP.L<DSP.H	EU	EU(-5.0%)	Always
LOCK	Key Lock	OFF, ON(No Editing)	ABS	OFF	Always
U.PWD	User Password	0 ~ 9999	ABS	0	Always
INIT	Parameter Initialization	OFF, ON	ABS	OFF	Always

Type of Input Sensor

*display range : -5% ~ +105%

No.	TYPE	Temp.Range(°C)	Temp.Range(°F)	Group	DISP
1	K1	-200 ~ 1370	-300 ~ 2500	T/C	TC.K1
2	K2	-199.9 ~ 999.9	0 ~ 2300		TC.K2
3	J	-199.9 ~ 999.9	-300 ~ 2300		TC.J
4	E	-199.9 ~ 999.9	-300 ~ 1800		TC.E
5	T	-199.9 ~ 400.0	-300 ~ 750		TC.T
6	R	0 ~ 1700	32 ~ 3100		TC.R
7	B	0 ~ 1800	32 ~ 3300		TC.B
8	S	0 ~ 1700	32 ~ 3100		TC.S
9	L	-199.9 ~ 900.0	-300 ~ 1600		TC.L
10	N	-200 ~ 1300	-300 ~ 2400		TC.N
11	U	-199.9 ~ 400.0	-300 ~ 750		TC.U
12	W	0 ~ 2300	32 ~ 4200		TC.W
13	Platinel II	0 ~ 1390	32 ~ 2500		TC.PL
14	PIA	-199.9 ~ 850.0	-300 ~ 1560	RTD	PTA
15	PIB	-199.9 ~ 500.0	-199.9 ~ 999.9		PTB
16	PTC	-150.0 ~ 150.0	-199.9 ~ 300.0		PTC
17	JPIA	-199.9 ~ 500.0	-199.9 ~ 999.9		JPTA
18	JPIB	-150.0 ~ 150.0	-199.9 ~ 300.0	JPTB	
19	0.4~2.0V	0.400 ~ 2.000V		DCV	2V
20	1~5V	1 ~ 5V			5V
21	0~10V	0 ~ 10V			10V
22	-10~20mV	-10 ~ 20mV		mV	20M
23	0~100mV	0 ~ 100mV			100M

Specification

- PV Data Display : 4 digits
- Sampling Time : 250ms
- Indication Accuracy : ±0.2% of FS
- Communication Protocols : PC-Link, MODBUS(ASCII, RTU)
- Power Supply and Consumption : 100 ~ 240V AC, 50 ~ 60Hz / Max 6W below

Sensor

- PV Input : Universal Input(1 Point)
- Type of Input
T/C : K, J, E, T, R, B, S, L, N, U, W, Platinel II
RTD : Pt100, JPt100
DCV : -10 ~ 20mV, 0 ~ 100mV, 0.4 ~ 2.0V DC, 1 ~ 5V DC, 0 ~ 10V DC
(4 ~ 20mA, 0 ~ 20mA, with external 250Ω, 500Ω)

Retransmission Output

- Control Output : 2 Points
- Type of Output : Current Output : 4~20mA, 0~20mA
Voltage Output : 0~100mV, 0~10V, 0~5V, 1~5V

Safety & EMC

- Safety : EN61010-1, UL61010C-1, CAN/CSA C22.2 No.10101-92, Category II
- EMC : EMI(Emission) - EN61326, ClassA
EMS(Immunity) - EN61326

IN GROUP

Symbol	Parameter	Setting Range	Unit	Initial	Remark
IN-T	Input Type	refer to "Type of Input Sensor"	ABS	TC.K1	Always
IN-U	Display Range	°C, °F	ABS	°C	T/C, RTD
IN.RH	Max. Value of Measurement Range	refer to "Type of Input Sensor" However, INRH > INRL	EU	EU(100%)	Always
IN.RL	Min. Value of Measurement Range		EU	EU(0.0%)	Always
IN.DP	Decimal Point Position	0 ~ 3	ABS	1	mV, V
IN.SH	Max Value of Input Scale	Within -1999 ~ 9999 however, INSH > INSL The Decimal Point Position is rely on the value of IN.DP	ABS	100.0	mV, V
IN.SL	Min Value of Input Scale			0.0	mV, V
IN.FL	PV Filter	OFF, 1 ~ 120	sec	OFF	Always
BSL	BOU SEL	OFF, UP, DOWN	ABS	UP (DCV=OFF)	Always
BS	Bias Value	EUS(-100.0 ~ 100.0%)	ABS	0	Always
RSL	RJC SEL	TC, TC.RJ, RJC	ABS	TC.RJ	T/C

RET GROUP

Symbol	Parameter	Setting Range	Unit	Initial	Remark
RT1.H	Upper-Limit Set Value of Retransmission Output1	T/C, RTD : INRH ~ INRL mV, V : INSH ~ INSL However, RT1.H > RT1.L	EU	INRH	Always
RT1.L	Lower-Limit Set Value of Retransmission Output1		EU	INRL	
RT2.H	Upper-Limit Set Value of Retransmission Output2	T/C, RTD : INRH ~ INRL mV, V : INSH ~ INSL However, RT2.H > RT2.L	EU	INRH	Option
RT2.L	Lower-Limit Set Value of Retransmission Output2		EU	INRH	

COMM GROUP

Symbol	Parameter	Setting Range	Unit	Initial	Remark
COM.P	Communication Protocol	PCC0, PCC1, MODBUS ASCII, MODBUS RTU	ABS	PCC0	Option
BAUD	Baud Rate	600, 1200, 2400, 4800, 9600, 19.2K	ABS	9600	Option
PRTY	Parity	None, Even, Odd	ABS	None	Option
SBIT	Stop Bit	1, 2	ABS	1	Option
DLEN	Data Length	7,8(SKIP in MODBUS)	ABS	8	Option
ADDR	Address	1 ~ 99(Max 31 can connect)	ABS	1	Option
RP.TM	Response Time	0 ~ 10(x10ms)	ABS	0	Option

Parameter Map

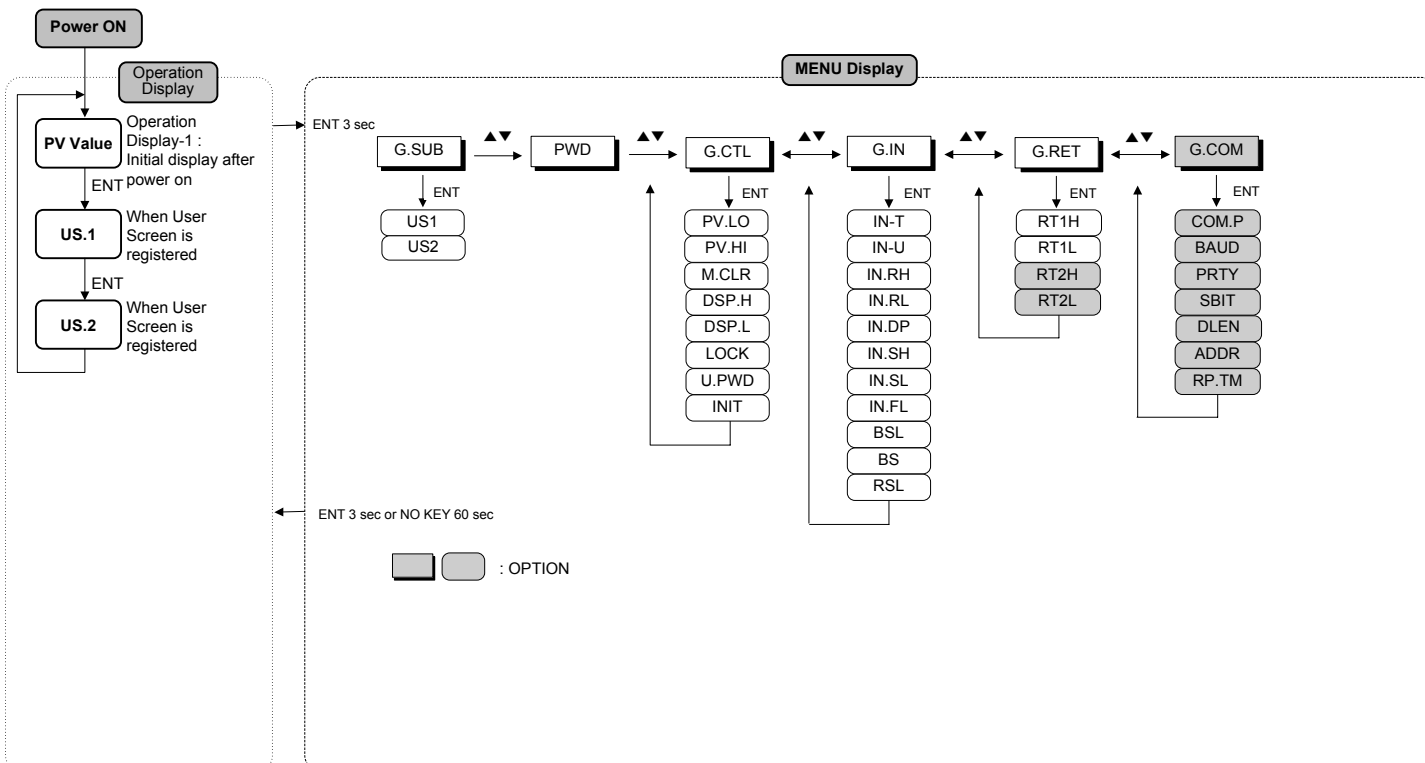

※ Operation in Power ON : Start in Operation MODE before Power OFF
· AUTO Operation MODE : Start Control from PO

Power Cable Connection

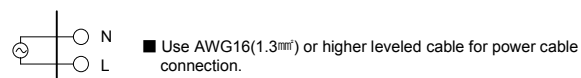

CAUTION Be sure to keep L(Hot) and N(neutral) status connection. Otherwise, it may result for operation default and defect.

ANALOG INPUT Connection

1. RTD INPUT

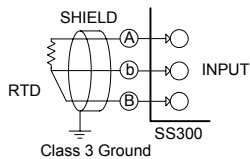

2. DC VOLTAGE INPUT

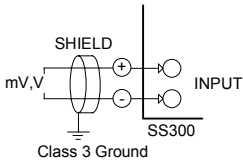

3. DC CURRENT INPUT

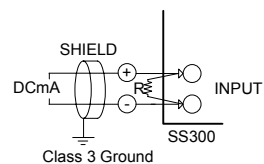

ANALOG OUTPUT Connection

CAUTION To prevent electric shock, be sure to turn off the SS300 Controller and the source circuit breaker before wiring.

1. Retransmission Output

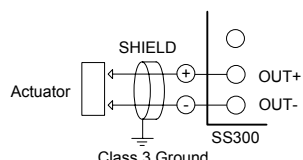

Current Output : 4~20mA, 0~20mA
Voltage Output : 0~100mV, 0~10V, 0~5V, 1~5V

CAUTION To prevent electric shock, be sure to turn off the SS300 controller and the source circuit breaker before connection/disconnection of the actuator as well as wiring.

Communication Wiring (RS485)

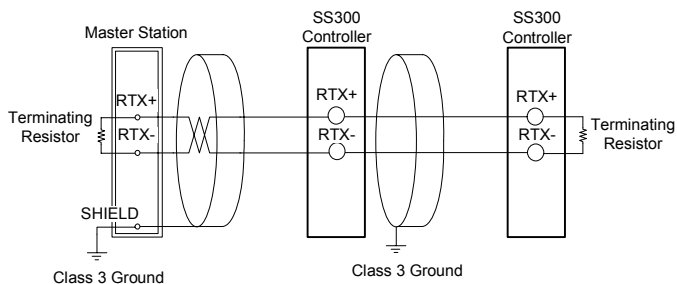

- Up to 31 slave controllers(SS300 instruments equipped with communication option) can be multidrop-connected.
- Be sure to connect terminating resistors(220Ω, 1/4W) to slave and master controllers at communication-channel ends as shown above.

CAUTION To prevent electric shock, be sure to turn off the SS300 controller and source circuit breaker before wiring.

Power Cable Specification

Power Cable Specification(1,2 Terminal) : AWG16(1.3mm²)

Cable Specification

Cable Specification(3~9 Terminal) : AWG26-16(0.13mm² ~ 1.3mm²)

CAUTION Never touch the terminal in the rear panel to prevent electric shock when power is supplied to the controller, and Be sure to turn off the electric power before wiring. Bind the wires connected to the controller terminals neatly together in order to prevent electromagnetic wave radiation.

Display Error and Correction

Display ERROR	ERROR Contents	Correction
E.SYS	EEPROM, DATA Loss	Ask repair
E.RJC	RJC SENSOR Failure	Ask repair
Flash Decimal point of SP	Communication Failure	Comm Cable CHECK
S.OPN	SENSOR Open	SENSOR CHECK

Terminal Arrangement and External wiring

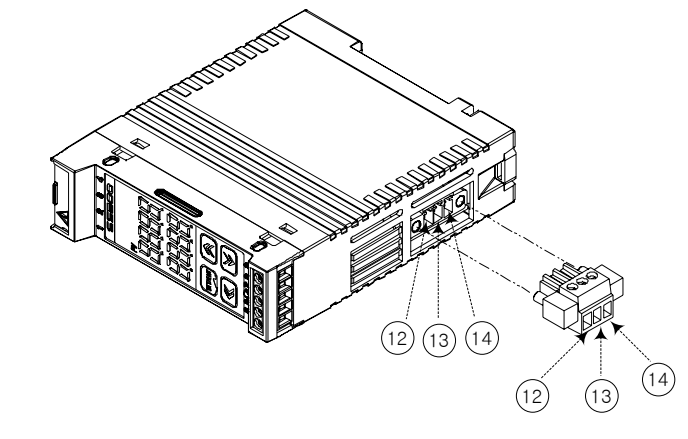
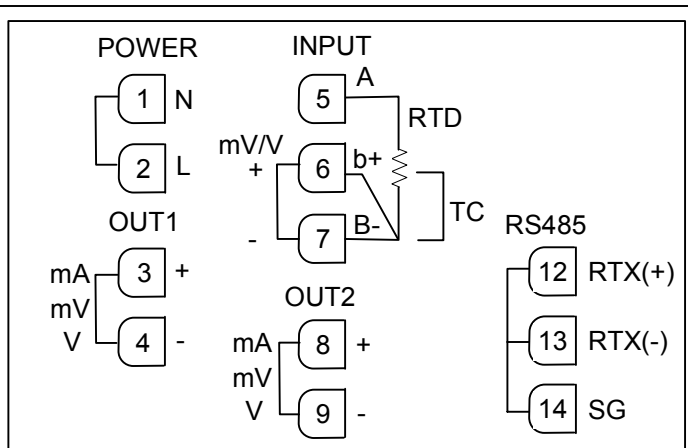

Dimension

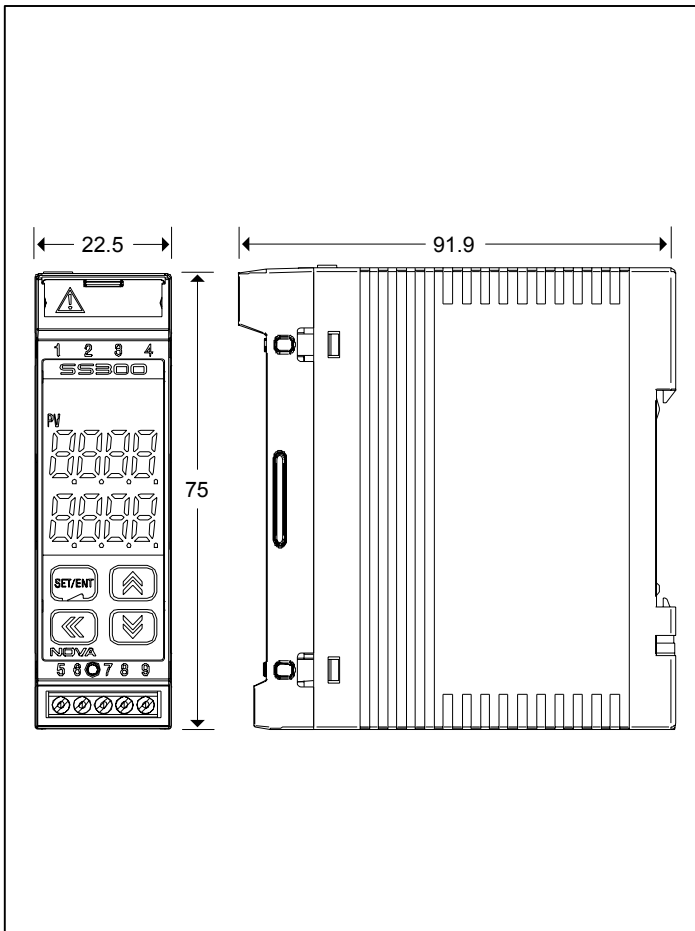

RAIL Installation

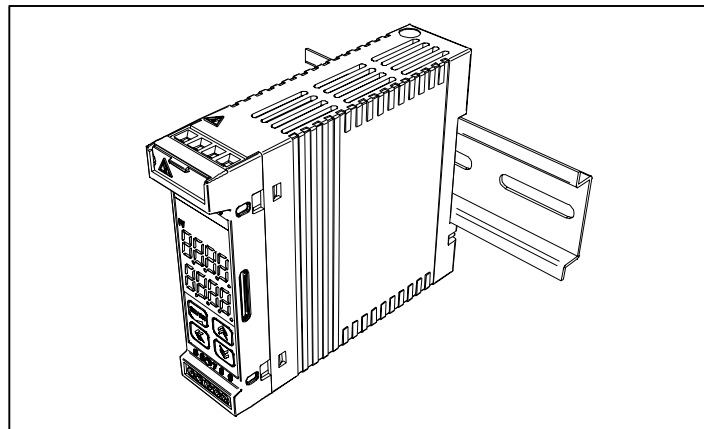

Assembly Method with Communication Function(Optional)

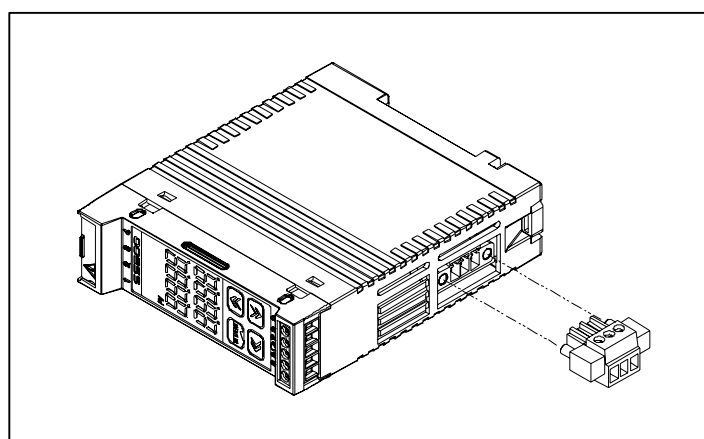

D-Register

NO	PROCESS	FUNCTION	CONTROL	HBA	ALARM	PID	IN/OUT
0	100	200	300	400	500	600	
0							
1	NPV						IN-T
2							IN-U
3			LOCK				IN.RH
4			DSP.H				IN.RL
5			DSP.L				IN.DP
6							BS
7							IN.SH
8			INIT				IN.SL
9			M.CLR				IN.FL
10							BSL
11							
12							
13							
14	ALSTS						
15							
16							
17							
18							RSL
19							
20							
21							
22	PV.LO						
23	PV.HI						
24							
25							
26							
27							
28							
29							
30							
31							
32							
33							

NO	PROCESS	FUNCTION	CONTROL	HBA	ALARM	PID	IN/OUT
0	100	200	300	400	500	600	
34							
35		US1					
36		US2					
37							
38							
39							
40							
41							
42							
43							
44							
45							
46							
47							
48							
49							
50							
51							
52							
53							RT2.H
54							RT2.L
55							RT1.H
56							RT1.L
57							
58							
59							
60							
61							
62							COM.P
63							BAUD
64							PRTY
65							SBIT
66							DLEN
67							ADDR
							RP.TM

NO	PROCESS	FUNCTION	CONTROL	HBA	ALARM	PID	IN/OUT
0	100	200	300	400	500	600	
68							
69							
70							
71							
72							
73							
74							
75							
76							
77							
78							
79							
80							
81							
82							
83							
84							
85							
86							
87							
88							
89							
90							
91							
92							
93							
94							
95							
96							
97							
98							
99							

(* Thick Line : Read Only)