

NOVA500^e SERIES

Instruction Manual ST590^e/580^e/570^e/540^e/510^e (Digital Controller)



WELCOME

Thank you for purchasing furnace controller production.
Please use after read instruction manual for safety.
Free to contact to our sales O/U for
production inquiry and after service.



Various

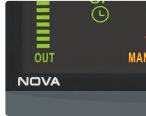

SAMWON
Promising the Best

As a general-purpose temperature controllers PLC supports automatic connection and timer outputs various output and products with a common control with heating and cooling control and Position proportional control.

<http://www.samwontech.com>

Being the controller market leader in the 21st century with the best technology



Copyright

Copyright© 2016 Samwon technology Co., Ltd

This operation manual is a work protected by the copyright law. A part or entire of this manual shall not be copied, air sent, distributed, translated or changed into the form to be read by electronic media or machine without prior written consent of Samwon technology Co., Ltd.



MSP-REM-S31-
NOVAESERIES

Part **I** **Instruction
Manual**



Safety Guide

Used symbol mark in this Instruction manual



- It means the "Handle with care" or "Cautions"

In case of violation of this point, it may cause the death, severe injury or the extreme damage on the product.

- (1) Product : It is marked on the points to be acknowledged certainly to protect the human body and device.
- (2) Instruction manual : It describes the cautions to prevent the cases of endangered situation on the life and body of the user due to the electric shock and so on.



- It means "Ground terminal"

Make the earth with the ground in case of product installation and controlling the product.



- It means the "supplementary explanation"

It describes the points to supplement the explanation.



- It describes the "references"

It describes the information and pages of reference to be referred.

Cautions in this Instruction manual

- Please deliver for the end user to possess always and keep it in the place accessible at any time.
- Use the product after full understanding of this installation manual.
- This installation manual does not warrant any other things because it is a description of the details for the function.
- A part or whole of this manual shall not be edited or copied randomly.
- The descriptions in this manual may be changed randomly without pre notice or warning.
- Even though this manual was made with elaboration, it will be appreciated if you inform to the purchasing point (Dealer shop and etc) or sales team in our company in case of deficiency, mistake or omission in the contents.

Safety Guide

Cautions for the safety and modification (Change) of the product

- Please use this product after full understanding on the safety cautions in this manual for the protection and safety for this product and the system connected to this system.
- Our company is not responsible to the damages occurred by using or handling or unattended using not relying on this installation manual.
- Please install at the outside of this product when the additional protection and safety circuit is installed. Otherwise for the protection and safety for this product and the system connected to this system.
- The internal modification (Change) and addition to this product are prohibited.
- Do not disassemble, repair and modify of this product because it becomes the reasons for electric shock, fire and malfunction.
- In case of changing the part or the consumables of this product, please contact to the sales department of our company.
- Do not contact to the moisture with this product. It may cause the failure on this product.
- Do not apply the strong impact on this product. It may cause the damage and failure on this product.

With regard to the exemption for the responsibility of this product

- We are not responsible for any warranty on this product besides the defined cases in the quality assurance condition of our company.
- We are not responsible for the direct or indirect damages on the user of any third party due to the not expectable defect or the natural disaster in use of this product.

With regard to the quality assurance condition of this product

- The warranty period shall be one year from the purchasing of this product. Free of charge repair is available only for the cases of out of order occurred from normal use conditions.
- The repair due to the out of order occurred after the warranty period shall be repaired at the actual cost according to the defined condition by our company.
- The out of order occurred within the warranty period shall be repaired at the actual cost for the following cases in spite of within the warranty period.
 - (1) Out of order due to the mistake or fault of the user (Ex: Initialization by losing the password and etc.)
 - (2) Out of order due to the natural disaster(Ex: Fire and flood and etc)
 - (3) Out of order due to the movement of product after installation.
 - (4) Out of order due to the random disassemble, change or damage on the product.
 - (5) Out of order due to the electric power instability.
 - (6) Others
- Please contact to the purchasing points or sales part of our company when after sales service is necessary because of the failure on the product.

Safety Guide

Environmental precautions for installation.

- Be sure to operate the controller installed on a panel to prevent electric shock.
- To install the controller, do select a location where:
 - (1) No one may accidentally touch terminal.
 - (2) Mechanical vibrations are minimal.
 - (3) No corrosive gas is present.
 - (4) Temperature fluctuation is minimal.
 - (5) Temperature can be maintained. (50 °C below / 10 °C over)
 - (7) No direct heat radiation is present.
 - (8) No magnetic disturbances are caused
 - (9) No water is splashed.
 - (10) No flammable materials are around.
 - (11) No wind blows. (prevent Dust with salt)
 - (12) No ultraviolet rays are present.

Precautions of Controller Mounting.

- Keep the input circuit wiring as far as possible away from power and ground circuit.
- Keep the controllers in 10°C ~ 50°C/ 20 % ~ 90 % RH, Warming up needed to use controller when temperature is below 10°C in advance.
- Do not mount front panel facing downward.
- To prevent electric shock, be sure to turn off and the source circuit breaker before wiring.
- The power consumptions are 100-240VAC, 50/60Hz, 10VAmax and operate without power switching in advance.
- No work in wet hands (it caused electric shock)
- Follow operation by precaution in the manual to avoid fire, electric shock, loss of life etc.
- Requested to follow mounting and operation methods just indicated in this manual.
- Refer the way of grounding connection, however, keep away for grounding to Gas pipe, water pipe, lightning rod etc.
- Be sure not to power connection before finishing of wiring between each contact point.
- Not close and wrapping the heat hole in back case of controller.

Rated Voltage and Power Consumption



- This product runs on 100-240VAC, 50/60Hz 10VA max.
 - It runs on 24VDC, 4.1VA max when using DC Power.
 - Risk of electric shock and fire if use power source in rating other than specified.
-

Engineering Units - EU, EUS

- EU and EUS are used for the scaling of the parameters of the controller.
- When the sensor type (IN-T) or the high limit, low limit of input range is changed, the parameters expressed in EU(), EUS() are changed in proportion to current data. (However, the high/low range setting data is initialized.)

☞ EU() : Value of engineering unit depending on the range of instrument

☞ EUS() : Value of engineering unit depending on the span of instrument

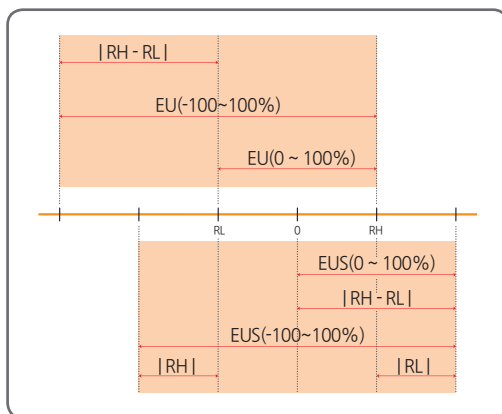

RL : Low limit of input range

RH : High limit of input range

※ The Range of EU(), EUS()

	Range	Center point
EU(0 ~ 100%)	RL ~ RH	$ RH - RL /2 + RL$
EU(-100 ~ 100%)	$- (RH - RL + RL) \sim RH$	RL
EUS(0 ~ 100%)	$0 \sim RH - RL $	$ RH - RL /2$
EUS(-100 ~ 100%)	$- RH - RL \sim RH - RL $	0

※ Ex) INPUT = TC.K2

RANGE = -200.0°C(RL) ~ 1370.0°C(RH)

	Range	Center point
EU(0 ~ 100%)	-200.0 ~ 1370.0°C	585.0°C
EU(-100 ~ 100%)	-1770.0 ~ 1370.0°C	-200.0°C
EUS(0 ~ 100%)	0 ~ 1570.0°C	785.0°C
EUS(-100 ~ 100%)	-1570.0 ~ 1570.0°C	0.0°C

Displays of the product

Numbers · Character in 7-Segment

- Numbers · Character in 7-Segment LED Display

0	1	2	3	4	5	6	7
0	1	2	3	4	5	6	7
8	9	.	-	/	Half -	Half 1	Half -1
8	9	.	-	/	Half -	Half 1	Half -1

Alphabets in 7-Segment

- Alphabets in 7-Segment LED Display

A, a	B, b	C, c	D, d	E, e	F, f	G, g	H, h
A, a	B, b	C, c	D, d	E, e	F, f	G, g	H, h
I, i	J, j	K, k	L, l	M, m	N, n	O, o	P, p
I, i	J, j	K, k	L, l	M, m	N, n	O, o	P, p
Q, q	R, r	S, s	T, t	U, u	V, v	W, w	X, x
Q, q	R, r	S, s	T, t	U, u	V, v	W, w	X, x
Y, y	Z, z						
Y, y	Z, z						



Precautions
Numeric 5 and alphabet S appear the same way

Contents

I Instruction Manual	1
1. Product Dimensions and Installation	10
1.1. Dimension and Panel Cutout.....	10
1.2. How to install Mount	15
1.3. Power Cable Specification	16
1.4. Terminal Specification	16
1.5. Terminal Arrangement and External wiring	17
1.6. Power Cable Wiring	22
1.7. Analog Input Wiring	23
1.7.1. RTD Input	23
1.7.2. DC Voltage Input	23
1.7.3. DC Current Input	23
1.8. Analog Output Wiring	24
1.8.1. Voltage Pulse Output(SSR)/Current Output(SCR)	24
1.8.2. Retransmission Output(RET)	24
1.9. External Contact Input Wiring(DI)	25
1.10. External Contact Output Wiring(RELAY)	26
1.11. Communication Wiring (RS485)	27
1.12. HBA Wiring.....	27
2. Control Keys and Display	28
3. Flow of Operating Display	29
4. Parameter Map	30
5. Setting Up Parameter in each Group	34
5.1. Auto Tuning Group(G,AT)	34
5.1.1. Auto tuning	34
5.1.2. GAIN Setting	34

Contents

5.2. SP Group(G.SP)	37
5.2.1. Run/Stop Selection Setting	37
5.2.2. Select SP Kind Setting	37
5.2.3. SP Setting	38
5.2.4. SP High/Low Limit Setting	38
5.2.5. Time Unit Setting	38
5.2.6. Slope of ramping up/down Setting	39
5.3. PID Group(G.PID)	40
5.3.1. Anti Reset Wind-Up Setting	40
5.3.2. Control Mode Setting	42
5.3.3. Fuzzy Function Setting	43
5.3.4. PID Number Setting	44
5.3.5. Proportional Band Setting	44
5.3.6. Integration Time Setting	44
5.3.7. Derivation Time Setting	45
5.3.8. Manual Set Value Of Integration Time Setting	45
5.3.9. Proportional Band (Cooling Control) Setting	45
5.3.10. Integration Time (Cooling Control) Setting	46
5.3.11. Derivation Time (Cooling Control) Setting	46
5.3.12. Heater And Cooler Dead Band Setting	46
5.3.13. PID Zone Setting	47
5.3.14. PID Hysteresis Setting	47
5.3.15. Deviation Value Setting	47
5.4. Control Functions Group(G.CTL)	50
5.4.1. Power Mode Setting	50
5.4.2. Process Timer Operation Mode Setting	50
5.4.3. Reservation RUN Setting	51
5.4.4. Run Time Setting	51
5.4.5. Auto/Man Control Setting	51
5.4.6. Valve Auto/Man Control Setting	52
5.4.7. User Screen Setting	52
5.4.8. Key Lock Setting	52
5.4.9. External Contact Input(DI) Setting	53
5.4.10. Output Status Display Setting	54
5.4.11. PV Display High/Low Limit Setting	54
5.4.12. Password Setting	54
5.4.13. ON/OFF Mode Setting	55
5.4.14. Initialization of The Controller	55

Contents

5.5. Input Group(G.IN)	56
5.5.1. Input Type Setting	56
5.5.2. Input Unit Setting	56
5.5.3. Input Range Setting	59
5.5.4. Decimal Point Setting	59
5.5.5. PV Display Range Setting	60
5.5.6. Input Filter Setting	60
5.5.7. Display Filter Setting	61
5.5.8. PV Direction Setting During Sensor-Open	61
5.5.9. Reference Junction Compensation Setting	61
5.5.10. All Bias Setting	62
5.5.11. Piece Bias Setting	62
5.6. Control Output Group(G.OUT)	65
5.6.1. Output Types Setting	65
5.6.2. Output Direction Setting	67
5.6.3. Output Cycle Setting	68
5.6.4. Valve Control Mode Setting	69
5.6.5. Valve Calibration(AUTO) Setting	69
5.6.6. Valve High/Low Position Calibration(MAN) Setting	70
5.6.7. Valve Traveling Time Setting	71
5.6.8. Output High / Low Limit Setting	71
5.6.9. Output Process Rate Setting	72
5.6.10. Hysteresis Setting	72
5.6.11. Valve Bead Band Setting	73
5.6.12. ON/OFF Mode Hysteresis Setting	74
5.6.13. Emergency Output Setting	75
5.6.14. Output LED Setting	75
5.7. Alarm Group(G.ALM)	76
5.7.1. Alarm Type Setting	76
5.7.2. Alarm Point Setting	76
5.7.3. High/Low Deviation Alarm Setting	77
5.7.4. Hysteresis Setting	77
5.7.5. Delay Time Setting	78
5.7.6. Alarm Mode Setting	78
5.7.7. Soak deviation Setting	80

Contents

5.8. Inner Signal Group(G.IS)	82
5.8.1. Type to be referenced Setting	82
5.8.2. Out or In band Setting	82
5.8.3. High/Low limits of band Setting	83
5.8.4. Delay Time Setting	83
5.9. Timer Group(G.TMR)	86
5.9.1. Timer operation Setting	86
5.9.2. Type of Timer Setting	86
5.9.3. Timer time unit Setting	87
5.9.4. Timer time Setting	87
5.10. Heater Current Alarm Group(G.HBA)	90
5.10.1. Heater current display Setting	90
5.10.2. Heater current alarm point Setting	90
5.10.3. Heater break dead band Setting	91
5.10.4. Power frequency Setting	91
5.10.5. CT Sensor Step-Up Ratio Setting	92
5.10.6. Bar Graph Setting	92
5.10.7. Heater Break Graph High/Low Setting	92
5.11. Loop Break Alarm Group(G.LBA)	93
5.11.1. Loop Break Alarm Setting	93
5.11.2. Loop Break Alarm Dead Band Setting	94
5.11.3. Loop Break Alarm Time Setting	94
5.12. Retransmission Group(G.RET)	95
5.12.1. Type of Retransmission Setting	95
5.12.2. High/Low Limits of Retransmission Setting	95
5.13. Communication Group(G.COM)	97
5.14. PLC Group(G.PLC)	99
5.15. Now PLC Display Group(G.NPL)	102
6. Display Error and Correction	104
II Communication Manual	105

1. Product Dimensions and Installation

1.1. Dimension and Panel Cutout

ST590^o

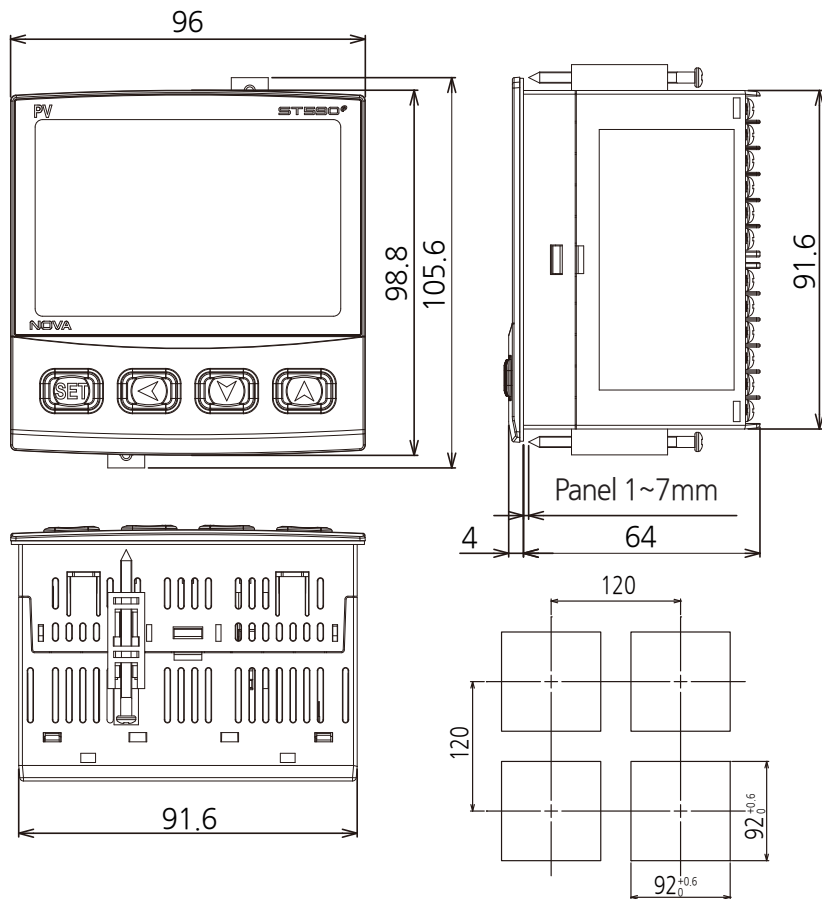

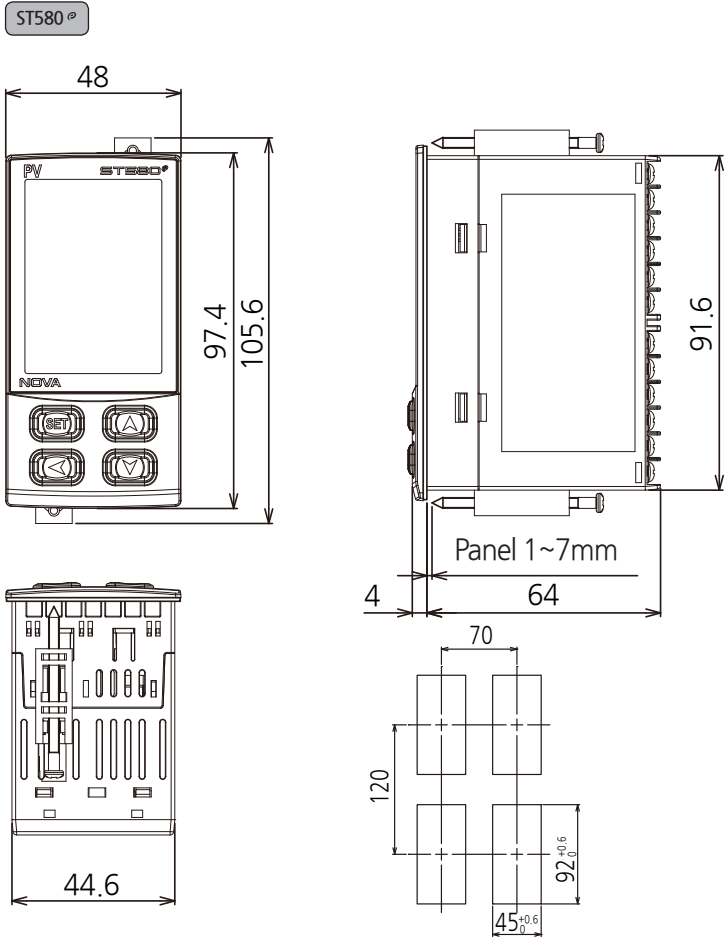

ST570^o

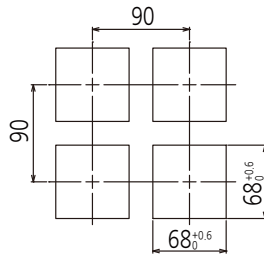
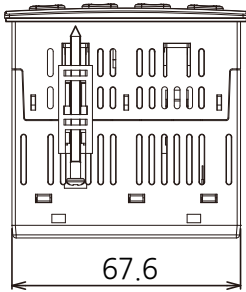
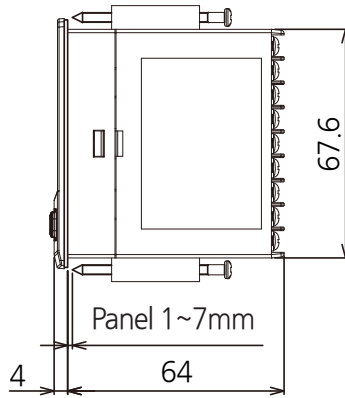
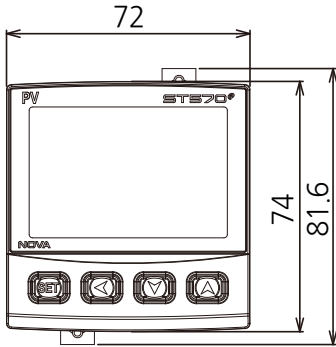

ST540^o

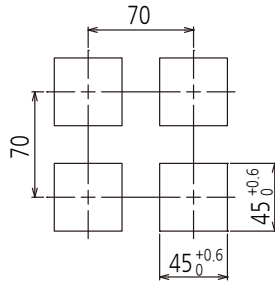
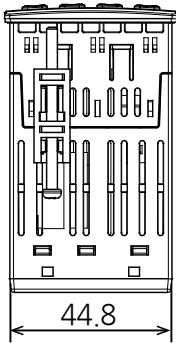
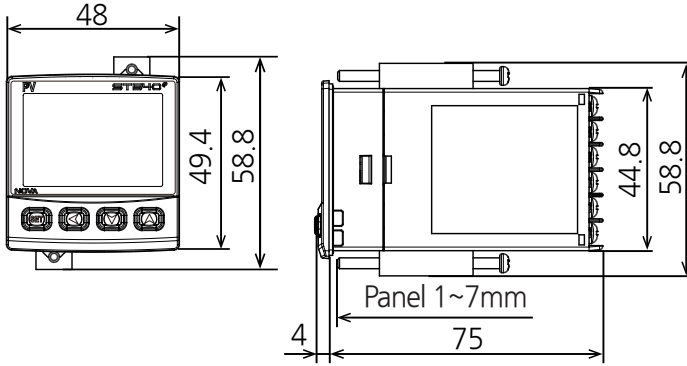

ST510^o

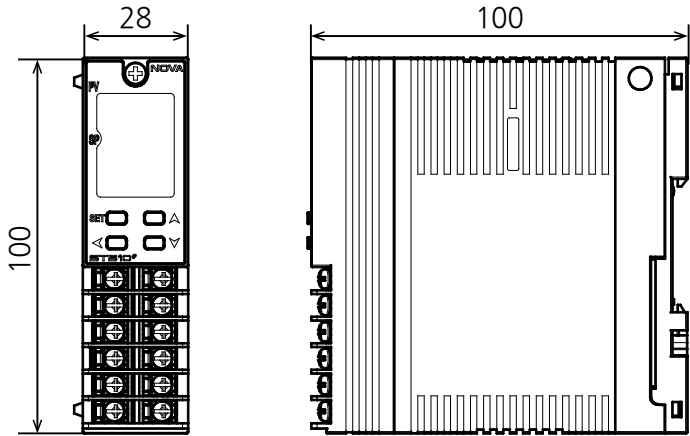

1.2. How to install Mount

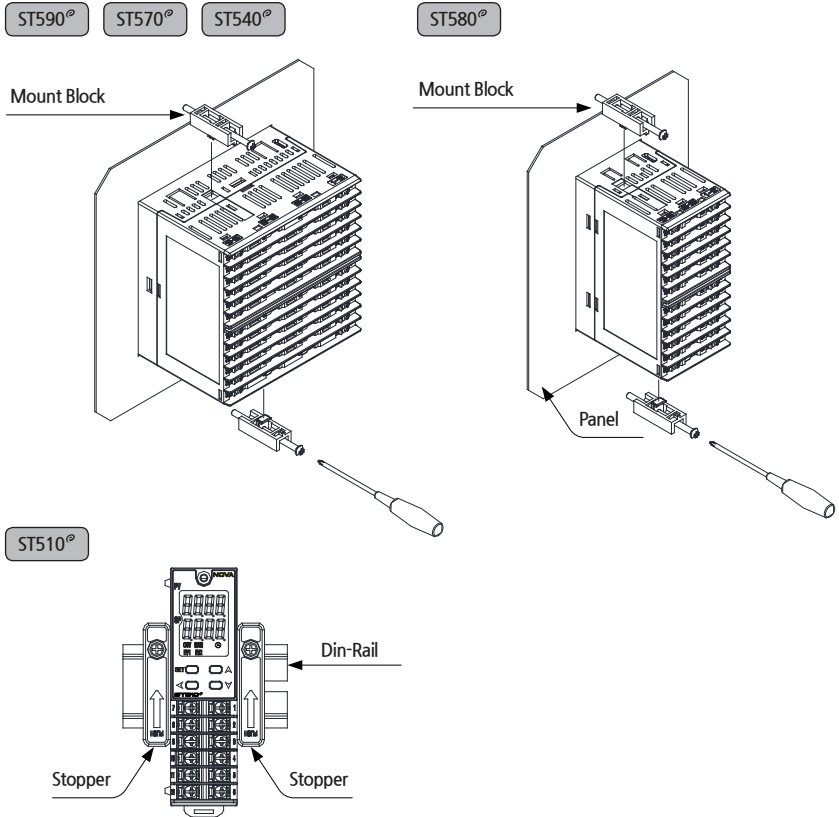

- 1) Cut the mounting panel. [Refer to 1.1. Dimension and Panel Cutout]
- 2) Insert the controller into the panel cutout with the rear terminal board facing ahead.
- 3) Attach the right and left mount and fix it to the panel. (Use driver)
- 4) ST510^o should be installed using a Din-Rail stopper.

Caution when fastening the mount



- Do not apply excessive force when fastening the mount on the account that the part may become damaged.
- Max torque when fastening the mount should not exceed $0.25\text{N} \cdot \text{m}$.

1.3. Power Cable Specification

- Vinyl insulated wire 0.9~2.0mm

1.4. Terminal Specification

- Use M3 screw-compatible crimp-on terminals with insulating sleeve as shown below.

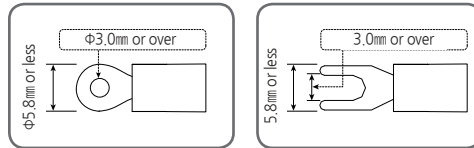

- First Turn off the source circuit breaker, check to ensure that the power cable is not conducting electricity using a tester, and then proceed with wiring in the manner.
 - Never touch the terminal in the rear panel to prevent electric shock when power is supplied to the controller.
 - Be sure to turn off the electric power before wiring.
- Bind the wires connected to the controller terminals neatly together in order to prevent electromagnetic wave radiation.
- Recommended tightening torque : 0.4N·m ~ 0.55N·m

ST580[®]

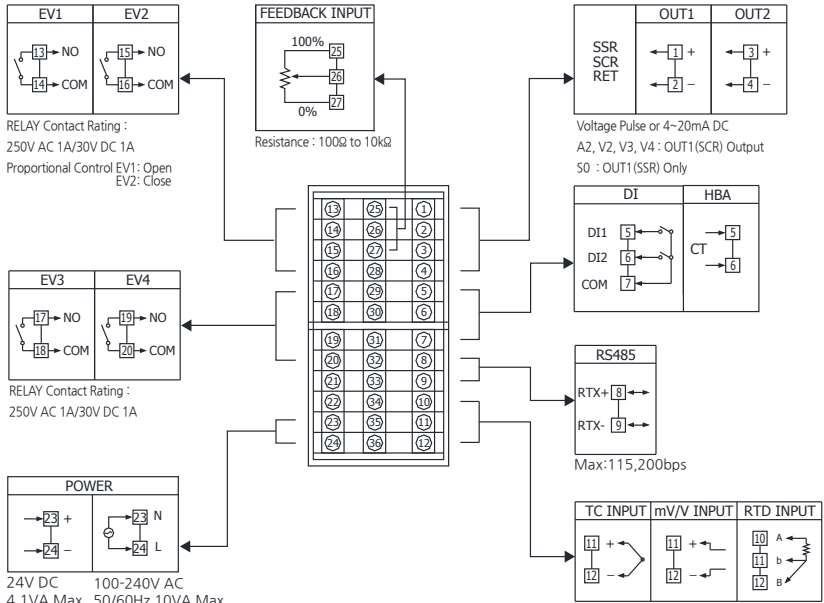

ST570[®]

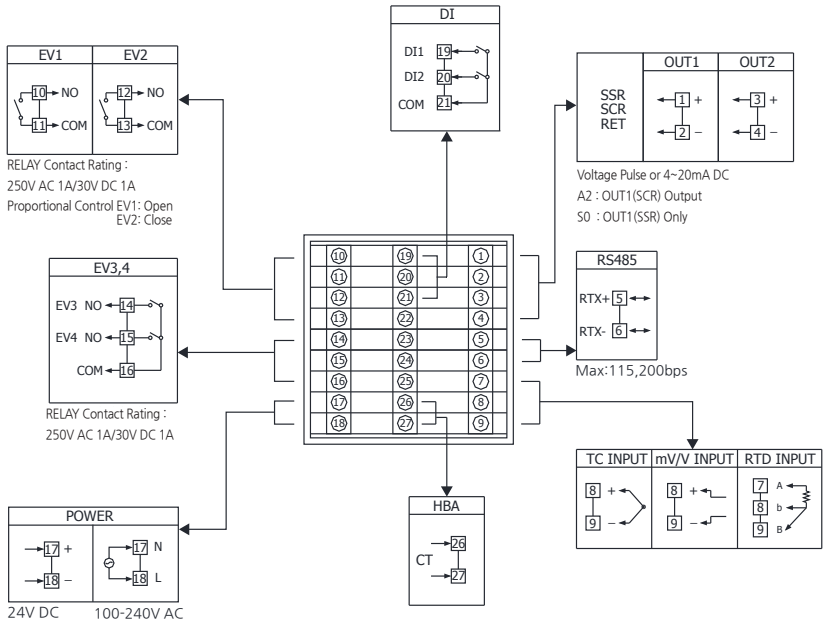

ST540[®]

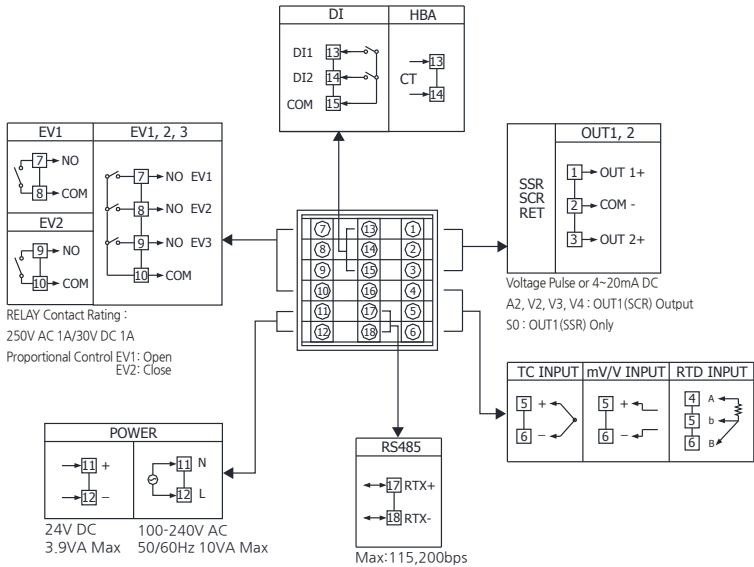

ST510[®]

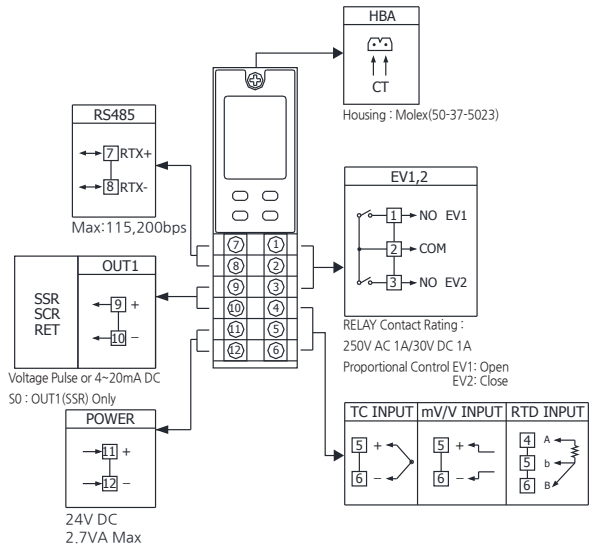

1.6. Power Cable Wiring

- Use Vinyl insulation wire 0.9~2.0mm (Allowed Rating Voltage 300V max) or higher leveled cable for power cable connection.
- Use the main power disconnect device in case of abnormal situations occur.

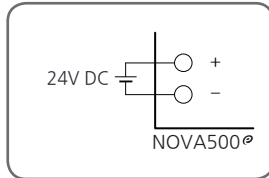
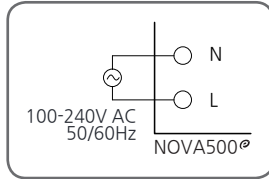

- For power connection, make sure that N-phase and L-phase (+ and - phases for DC Power) are connected.
- Turn off the power of NOVA500[®] when wiring the terminal to prevent electrical shock.
- DC Power will operate at 24V DC, 4.1VA Max.
- ST510[®] is available up to 10 connections for multi-connection.

1.7. Analog Input Wiring



- Be sure to connect to correct polarities, Connecting to a wrong polarity may cause unexpected malfunction.
- Use shielded wires and ground the shielding to an independent grounding point.
- Keep the input circuit wiring as far as possible away from the power and ground circuit.
- Use a wire having a low conductor resistance and no three-wire resistance differential.

1.7.1. RTD Input

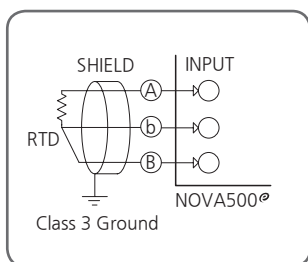

1.7.2. DC Voltage Input

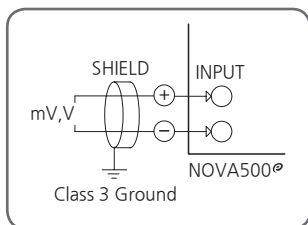

1.7.3. DC Current Input

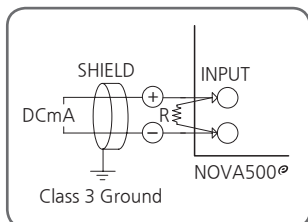

1.8. Analog Output Wiring



- To prevent electric shock, be sure to turn off the NOVA500[®] Controller and the source circuit breaker before wiring.
- Be sure to connect to correct polarities. Connecting to a wrong polarity may cause serious trouble.
- Use shielded wires for the wiring and, Be sure to connect independently(1 point grounding)

1.8.1. Voltage Pulse Output(SSR)/Current Output(SCR)

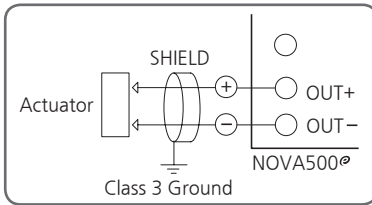

SCR : 4 ~ 20mA DC, 500Ω max
 SSR : 12V DC, 600Ω min (AC Power)
 24V DC, 600Ω min (DC Power)



To prevent electric shock, be sure to turn off the NOVA500[®] controller and the source circuit breaker before connection/disconnection of the actuator as well as wiring.

1.8.2. Retransmission Output(RET)

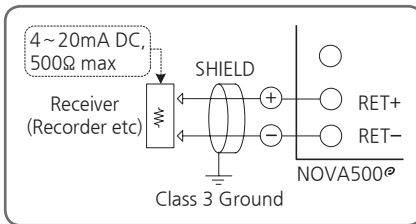

To prevent electric shock, be sure to turn off the NOVA500[®] controller and the source circuit breaker before connection/disconnection of the receiver as well as wiring.

1.9. External Contact Input Wiring(DI)

- Use a no-voltage contact such as relay contact.
- It has an ample switching capacity for the terminal's OFF voltage (approx. 5V) and On current (approx. 1mA)
- When using Open Collector(TR), use one with 2V or low voltage when the contact is ON and 100 μ A or less leakage current when it is OFF.

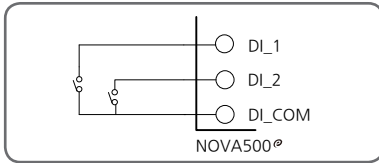

▲ RELAY Contact Connection

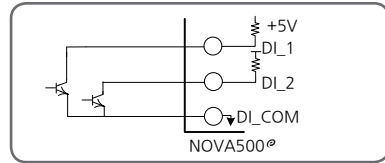

▲ TRANSISTOR Contact Connection



To protect electric shock, be sure to turn off the NOVA500[®] controller and the source circuit breaker before External Contact Input wiring.

1.10. External Contact Output Wiring(RELAY)

- When using an auxiliary relay or inductance load (L) such as solenoid, be sure to insert a CR filter(for AC) or diode (for DC) in parallel as a surge-suppressor circuit to reject sparks, preventing malfunction or damage. Recommended CR filters are as follows.

- Recommended CR FILTER

- ▶ Seong Hoo Electronics : BSE104R120 25V (0.1 μ +120 Ω)
- ▶ HANA PARTS CO. : HN2EAC
- ▶ Songmi Eolectic co.,Ltd : CR UNIT 953, 955 etc
- ▶ Jivol Electric Co.,Ltd : SKV, SKVB etc
- ▶ Shinyoug Communications Co.,Ltd : CR-CF5, CR-U etc

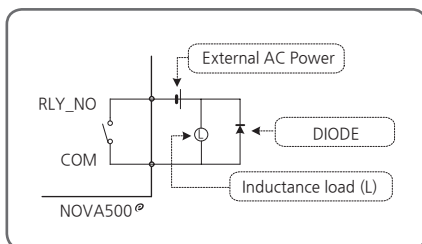

▲ In case of DC Power

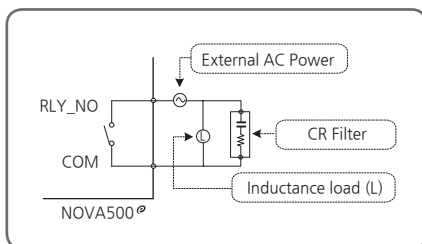

▲ In case of AC Power

- In case resistance load exceeds specification, turn on/off the load using an auxiliary relay.
- Turn off the power of NOVA500[®] when wiring external contact output to prevent electrical shock.
- DIODE and CR filter connection**
Directly connect to inductance (L) load socket.
- Auxiliary relay connection**
Auxiliary relay coil rating must be below that of controller contact capacity.
(Relay contact capacity : 250VAC 1A / 30VDC 1A)



1.11. Communication Wiring (RS485)

- Up to 31 slave controllers (NOVA500[®]) series instruments equipped with communication option can be multidrop-connected.
- Be sure to connect terminating resistors (220Ω, 1/4W) to slave and master controllers at communication-channel ends as shown above.

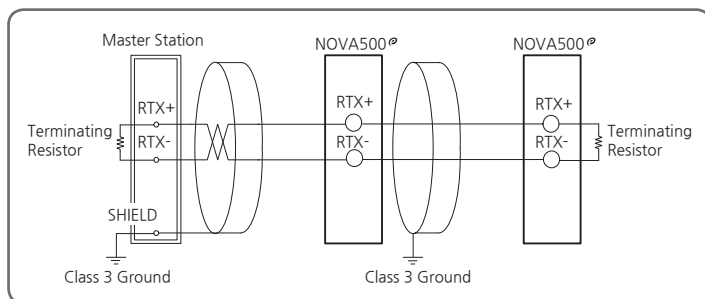

To prevent electric shock, be sure to turn off the NOVA500[®] controller and source circuit breaker before Communication wiring.

1.12. HBA Wiring

- Current ratio of the CT sensor, please use 800 : 1, 1000 : 1 product.
- The HBA is not detected when SCR control.

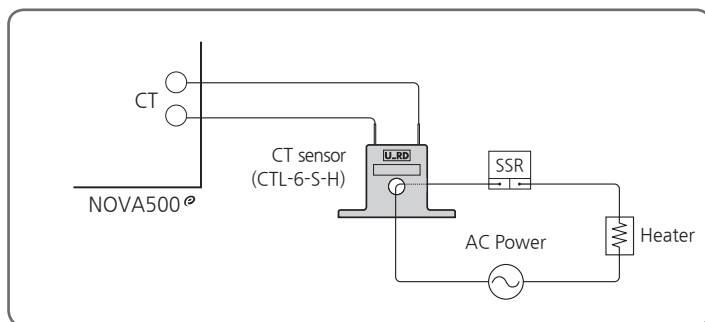

[Fig.1] HBA Connection



To prevent electric shock, be sure to turn off the NOVA500[®] controller and source circuit breaker before HBA wiring.

2. Control Keys and Display

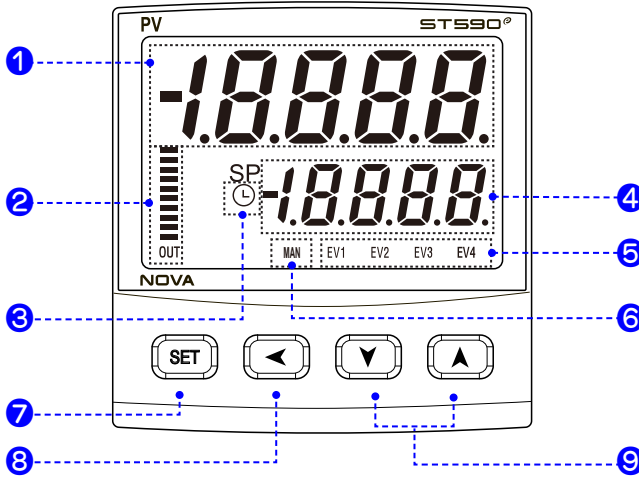

No.	Contents
①	PV display, Parameter Symbol
②	<ul style="list-style-type: none"> MV Bar Graph display <ul style="list-style-type: none"> 90.1 ~ 100.0% : Lights on 10 80.1 ~ 90.0% : Lights on 9 ⋮ 10.1 ~ 20.0% : Lights on 2 0.1 ~ 10.0% : Lights on 1 0% : All Lights off OUT LAMP : When Proportional Control Lights off When Proportional Control, Display the Valve B.GRP : When CUR, Heater current display
③	<ul style="list-style-type: none"> Lights off at the time of the run start booking Lights on at the time of the end booking
④	SP Set, Parameter Set
⑤	Lights on during EVENT

No.	Contents
⑥	<ul style="list-style-type: none"> Lights on during MAN Mode Lights off during AUTO Tuning
⑦	<ul style="list-style-type: none"> Used in switching between parameters or registering parameter settings. Used to change Display screen from RUN screen. Pressing the SET key for 3 sec from the RUN screen. → Move to the SET screen. Pressing the SET key for 3 sec from the SET screen. → Move to the RUN screen.
⑧	Used when shifting position to modify value
⑨	Used to change the value of parameters. Used to move between Group

3. Flow of Operating Display

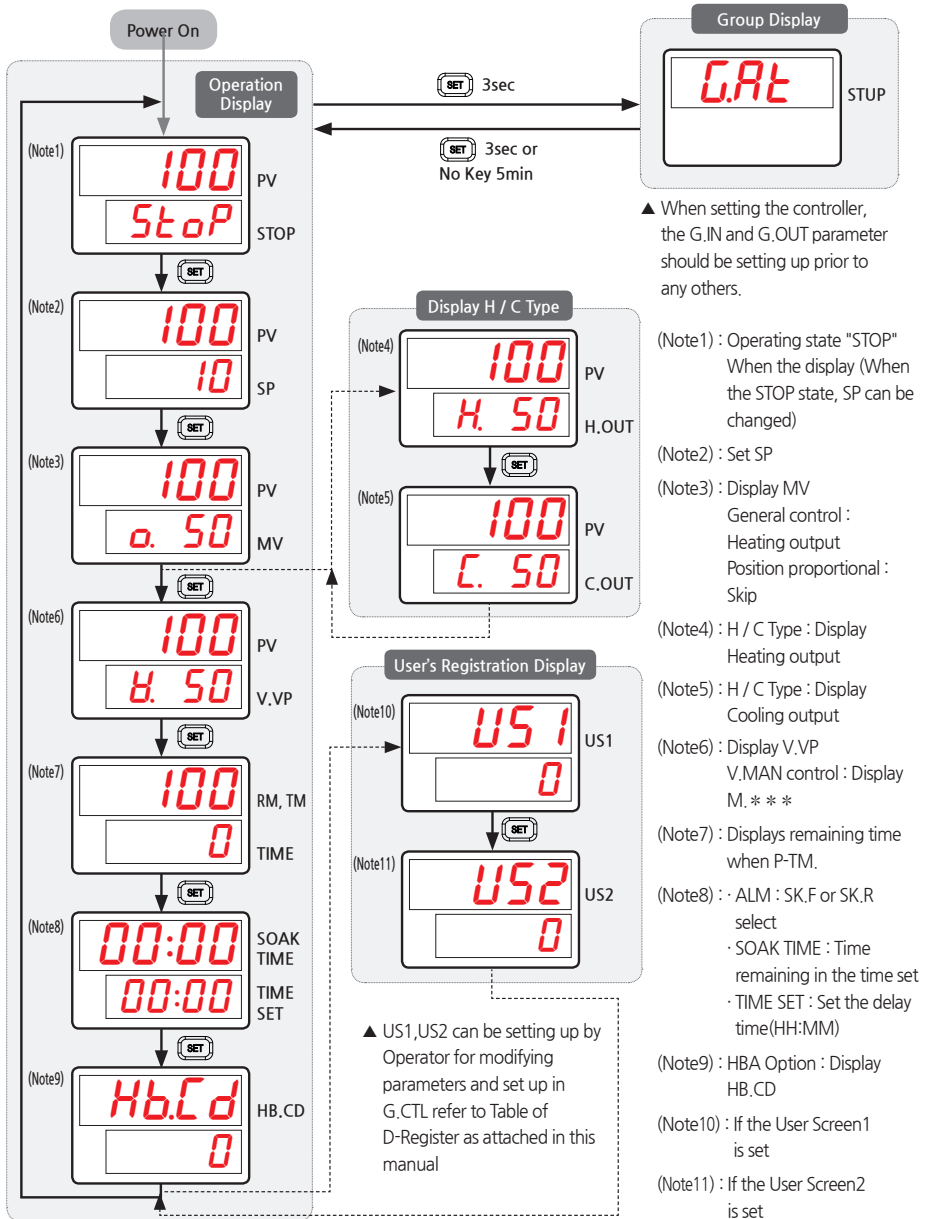

4. Parameter Map

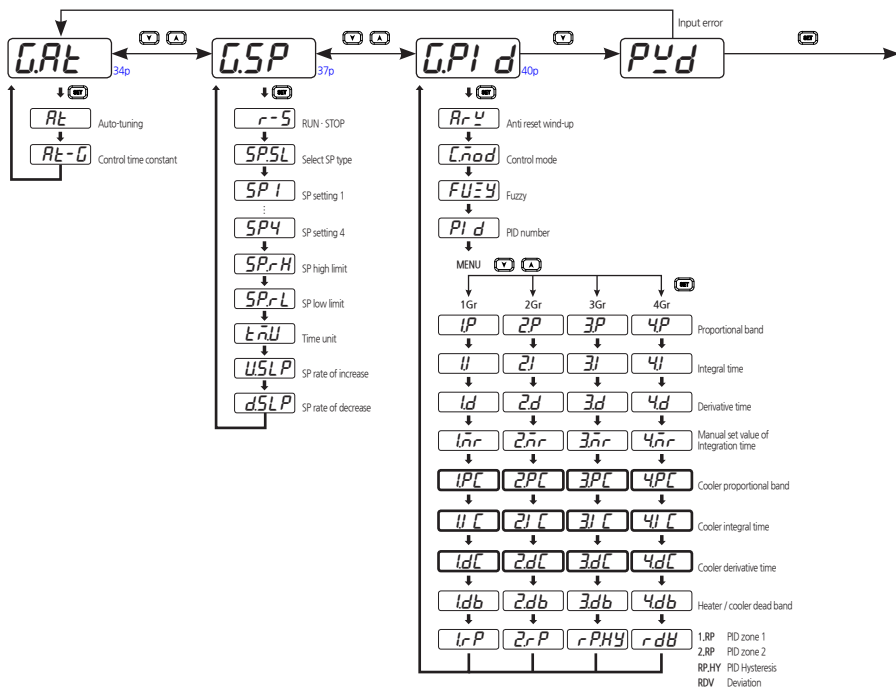

 : Option

 : H/C Type

* : When selecting OUT1, 2 HEAT, COOL.

P : Position proportional control.

S : When S0 Option, SKIP

ST510^o : Can not Use DI, EV3, EV4.

EV2 Option.

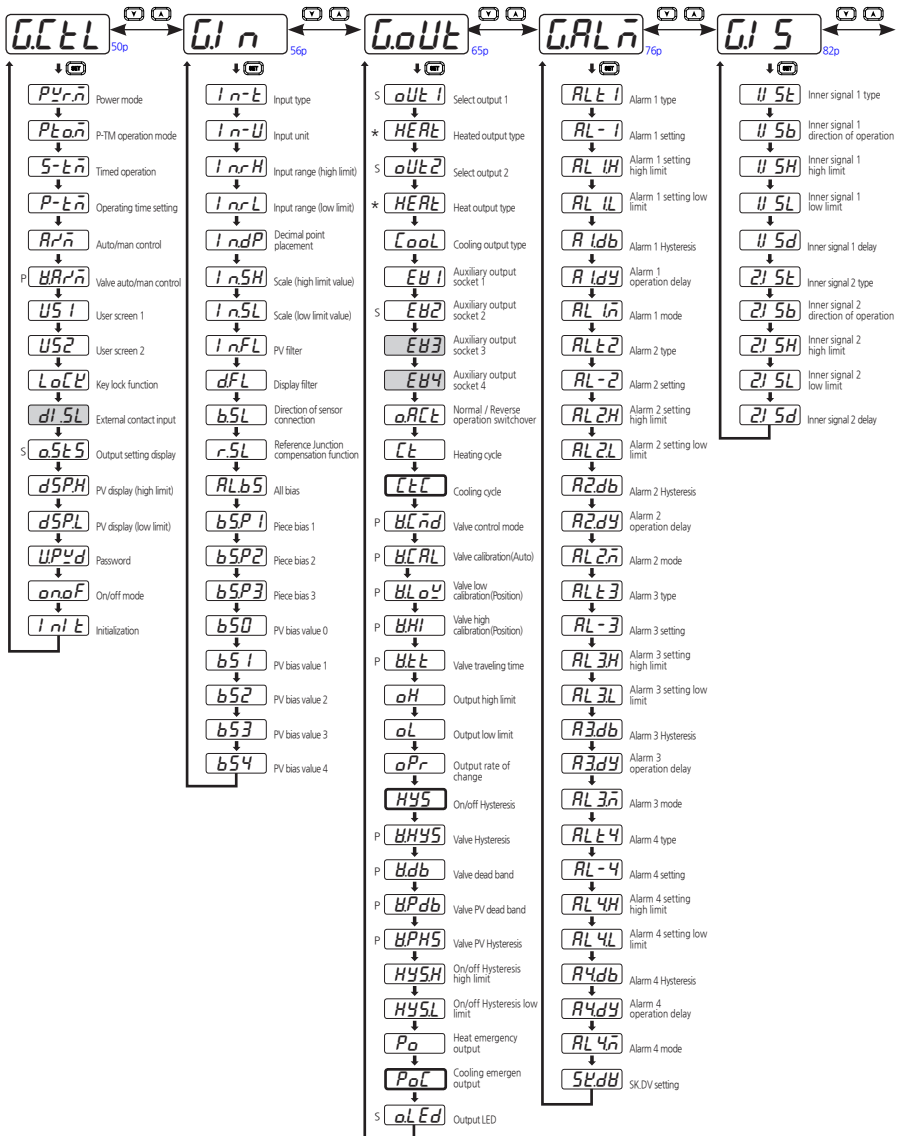

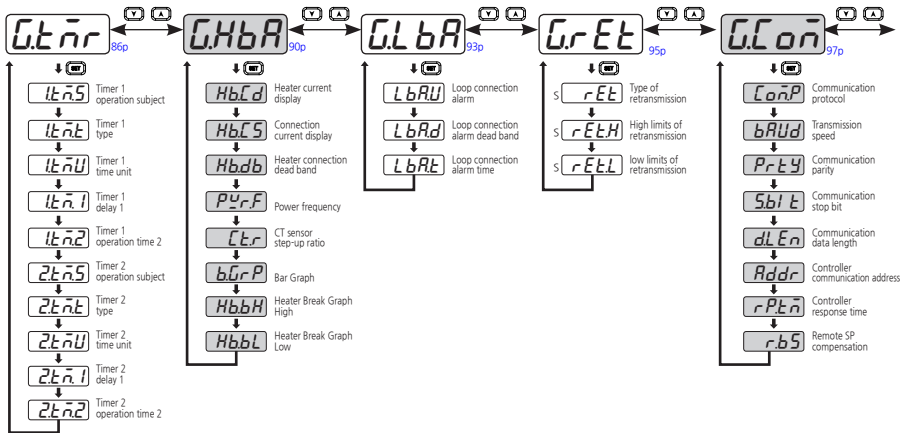

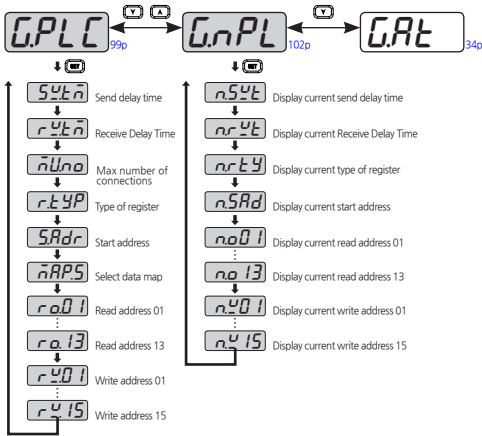

5. Setting Up Parameter in each Group

5.1. Auto Tuning Group(G,AT)



- Group of Auto Tuning parameters

5.1.1. Auto tuning



- Parameter for setting AUTO TUNING carry on.
- When AT sets 'ON' AUTO TUNING carry on.
- It will be skipped when sets 'STOP'.

Symbol	Parameter	Setting range	Unit	Default	Display
AT	Auto Tuning	OFF, ON	ABS	OFF	AUTO

5.1.2. GAIN Setting

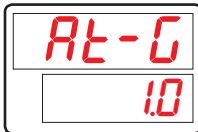

- Parameter for stinging for proportional PID value by obtaining AUTO TUNING.
- Reduce AT-G, Cycle time became rapid and, Increase AT-G, control status became more stable.
If it is smaller, hunting become more and more.
- It will be skipped when sets ON/OFF mode of G,CTL.

Symbol	Parameter	Setting range	Unit	Default	Display
AT-G	AT Gain	0.1 ~ 10.0	ABS	1.0	AUTO



G,AT setting method

※ Auto Tuning

■ The AUTO TUNING is

The AUTO TUNING is used to have the controller measure process characteristics and automatically set the most appropriate PID parameter. It makes ON/OFF control output to have Limit Cycle for control object and get the appropriate PID value calculated by steps and the responses.

■ Methods of AUTO TUNING

AUTO TUNING starts after TUNING Point for AUTO TUNING sets SP. The PID value sets automatically in PID zone positioned SP by setting up RP.

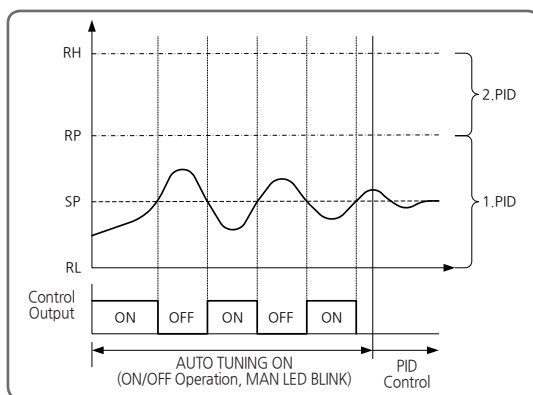

[Fig.2] Auto Tuning

■ AUTO TUNING during Heating/Cooling output.

AUTO TUNING of Heating/Cooling output can calculate as the same way by using Heating/Cooling output. The I.D value of AUTO TUNING will be recorded as the same value for Heating/Cooling Side.

■ Display during AUTO TUNING.

Main LED is blinking.

■ Change SP value during AUTO TUNING.

If the SP is changed during AUTO TUNING, the Tuning Point is maintained. After AUTO TUNING, it starts control for changed SP value.

■ Change PID parameter during AUTO TUNING.

It can be changeable for PID value during AUTO TUNING however, it obtains by calculation automatically after AUTO TUNING. But, when compulsory ending of AUTO TUNING except normal operation, it is controlled by changed PID value.

■ When abnormal Ending of AUTO TUNING.

- ① Compulsory Ending of AUTO TUNING.
- ② Input Sensor Open (S.OPN)during AUTO TUNING.
- ③ Measuring Cycle of AUTO TUNING is exceeding 24th.
- ④ Change control mode to Manual(MAN) during the operation.



NOTE

※ Starting Auto tuning and stopping it

■ Starting

- ① Check the control system, PV input and heater power.
- ② Check if f'MAN_lamp = OFF, in RUN mode not in READY mode.
- ③ Check if f'MAN_lamp = OFF, in Auto mode.
- ④ Set the parameter AT = ON.

■ Stopping

Auto tuning stops automatically. But by setting AT=OFF or setting Ready mode, AT process will be interrupted. Changing to READY mode or MANUAL mode will stop the AT process.

※ Auto Tuning Gain(AT GAIN)

- A parameter to adjust the gain of MV with respect to PID.
 - ☞ Generally, use the value obtained after auto tuning.
- To adjust the characteristics of control system, AT GAIN can be set manually.
 - ① If AT GAIN < 1.0, RESPONSE is fast, but PV hunting may occur..
 - ② If AT GAIN > 1.0, OVERSHOOT decreases, RESPONSE becomes slow.

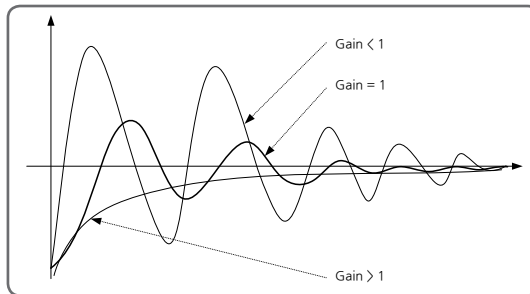

[Fig.3] Auto Tuning Gain(AT GAIN)

- AT can be done normally under controllable system condition (heater, sensor).
- AT can be started at RUN mode and when PV is in a normal range.
- At an abnormal situations, an Interruption of power or sensor burn-out during AT, AT will stop without changing PID parameters.
- The number of limit cycle or time can be different depending on the control system.
- MV will be ON and OFF for several times for limit cycle operation during AT procedure.
- In a special control system, optimal PID value cannot be obtained with AT. At this time, a user should adjust P, I, D value manually.



CAUTION

5.2.SP Group(G.SP)

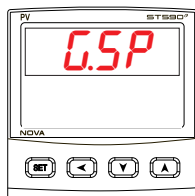

- Group of SP parameters.

5.2.1. Run/Stop Selection Setting

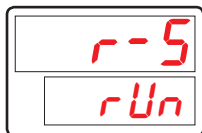

- Parameter for setting 'RUN' or 'STOP' controller.

Symbol	Parameter	Setting range	Unit	Default	Display
R-S	RUN/STOP Operation	RUN, STOP	ABS	RUN	Always

5.2.2. Select SP Kind Setting

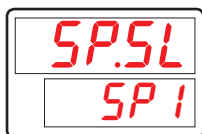

- Parameter for setting SP type for controller.
- RSP (Remote Set Point) : Set to sync SP with communication devices.

Symbol	Parameter	Setting range	Unit	Default	Display
SP.SL	SP Select	RSP, SP1, SP2, SP3, SP4	ABS	SP1	Always

5.2.3. SP Setting

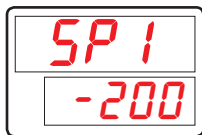

- Parameter for adjusting controller SP setting.
- Able to program up to 4 SP where one will be selected by SP.SL parameter for operation.

Symbol	Parameter	Setting range	Unit	Default	Display
SP1	Setting Point 1	EU(0.0 ~ 100.0%)	EU	EU(0.0%)	Always
SP2	Setting Point 2	EU(0.0 ~ 100.0%)	EU	EU(0.0%)	Always
SP3	Setting Point 3	EU(0.0 ~ 100.0%)	EU	EU(0.0%)	Always
SP4	Setting Point 4	EU(0.0 ~ 100.0%)	EU	EU(0.0%)	Always

5.2.4. SP High/Low Limit Setting

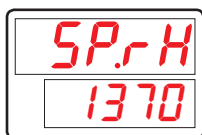

- Parameter for setting high/low limits when inputting SP.
- SP.RH/SP.RL will be initialized to IN.RH/IN.RL (IN.SH when inputting MV, V sensor) when setting sensor input or changing IN.RH/IN.RL.

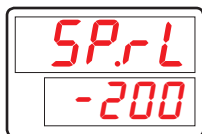

Symbol	Parameter	Setting range	Unit	Default	Display
SP.RH	SP Range High	EU(0.0 ~ 100.0%)	EU	EU(100.0%)	Always
SP.RL	SP Range Low	EU(0.0 ~ 100.0%)	EU	EU(0.0%)	Always

5.2.5. Time Unit Setting



- Parameter for setting time unit to either hour and minute (HH.MM) or minute and second (MM.SS).
- Only applies to U.SLP and D.SLP.

Symbol	Parameter	Setting range	Unit	Default	Display
TM.U	Time Unit	HH.MM, MM.SS	ABS	HH.MM	Always

5.2.6. Slope of ramping up/down Setting

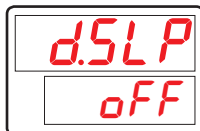

- Parameter for gradually increasing or decreasing SP proportion to the time to changed SP.
- Time unit for TMU parameters can be applied to U.SLP/D.SLP to set SP rate of increase or decrease per second or minute.
- If the value of U.SLP/D.SLP is off, when SP is change, the rate of change will not be applied. The currently input SP value will be applied to the controller.

Symbol	Parameter	Setting range	Unit	Default	Display
U.SLP	Up Slope	OFF(0), EUS(0.0%+1digit~100.0%)/min	EU	OFF(0)	Always
D.SLP	Down Slope	OFF(0), EUS(0.0%+1digit~100.0%)/min	EU	OFF(0)	Always



Operation of Slope

- When changing TSP, the ramping rate is given from NPV to TSP by gradually changing NSP.
- Amount of change to TSP = $[SP(TSP) - NPV]$ and Slope = 20.0°C/min.
 → $(70.0 - 30.0)^\circ\text{C} = 40.0^\circ\text{C}$, it will take 2 min to ramp up to TSP.
 ⇒ For 2 minutes, NSP will be changed from 30.0°C to 70.0°C at a constant rate of 20°C/min.

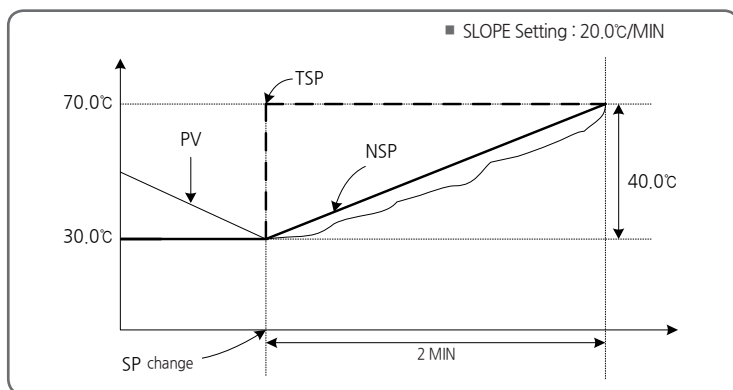

[Fig.4] Operation of SLOPE

5.3. PID Group(G.PID)

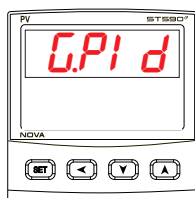

- Group of PID parameters.

⇒ It will be omitted of ON,OF (on/off mode) of G.CTL (control group) is on.

5.3.1. Anti Reset Wind-Up Setting



- Parameter for setting p-band to prevent overload.
- When controlled output is at maximum, integration is stopped to deter overshoot and switched over to ARW (anti-reset wind-up).
- If the setting is at AUTO, ARW will be operated automatically. ARW will operate at set value if adjusted other than AUTO.

Symbol	Parameter	Setting range	Unit	Default	Display
ARW	Anti-Reset Wind-Up Select	AUTO(0.0) ~ 200.0%	%	100.0%	Always



NOTE

Anti Reset Wind-Up (ARW)

- It is one of the methods for effective control in case of external disturbance.
 - It is a function to inhibit the over shoot by anti reset wind-up when the control output reached to the maximum point.
 - When $I = 0$, it is not operated in the PID setting data.
- ※ When there is no anti reset wind-up (ARW) function

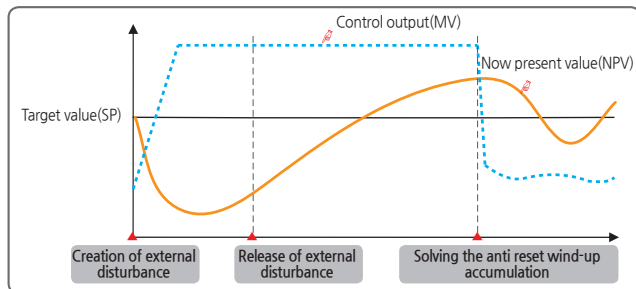

[Fig.5] When there is no anti reset wind-up (ARW) function



CAUTION

The over shoot is big as the time to solve the anti reset wind-up accumulation gets longer even though the external disturbance is released and it takes time for now present value to be stabilized.

- ※ When there is anti reset wind-up (ARW) function

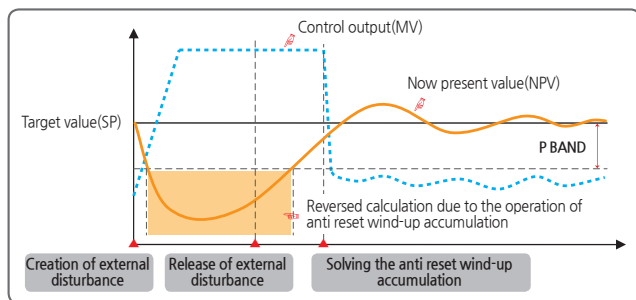

[Fig.6] When there is anti reset wind-up (ARW) function



CAUTION

The over shoot is small as the time to solve the anti reset wind-up accumulation gets shorter by reversed calculation of the anti reset wind-up before entering of now present value (NPV) to $\pm P$ Band and now present value is stabilized soon.

Creation of external disturbance : The now present value (NPV) is decreased and control output data (MV) is increased at the moment of external disturbance creation.

Release of external disturbance : The control output value (MV) is 100% output by the accumulated anti reset wind-up at the moment of release of external disturbance.

Solving the anti reset wind-up accumulation : Control output value (MV) is decreased by solving the anti reset wind-up accumulation

5.3.2. Control Mode Setting

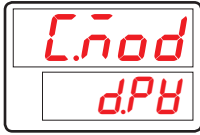

- Parameter for setting operation mode to D,DV or D,PV under PID control.

Symbol	Parameter	Setting range	Unit	Default	Display
C.MOD	Control Mode	D,PV, D,DV	ABS	D,PV	Always



Control Mode

- D,DV mode**
 - In D,DV mode, MV changes slowly. Overshoot is small but the delay may appear to reach SP.
 - It is suitable for a system which shows sensitive response to MV.

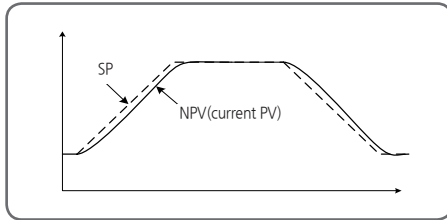

[Fig.7] D,DV mode

- D,PV mode**
 - In D,PV mode, MV changes quickly. Overshoot may occur but the time to reach the TSP is shorter.
 - It is suitable for a system which shows slow response to MV.

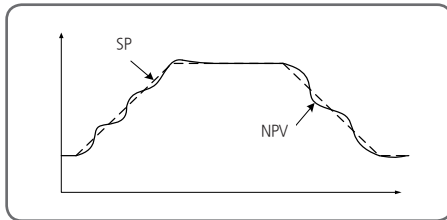

[Fig.8] D,PV mode

5.3.3. Fuzzy Function Setting

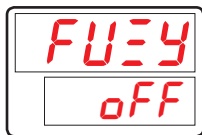

- Parameter for setting fuzzy function under controller control.
- Fuzzy function may deter overshoots when PV reaches SP or moderate load variance. (Refer to [Fig.9] Deterrence of Overshoot by Fuzzy Function).

Symbol	Parameter	Setting range	Unit	Default	Display
FUZY	Fuzzy Select	OFF, ON	ABS	OFF	Always

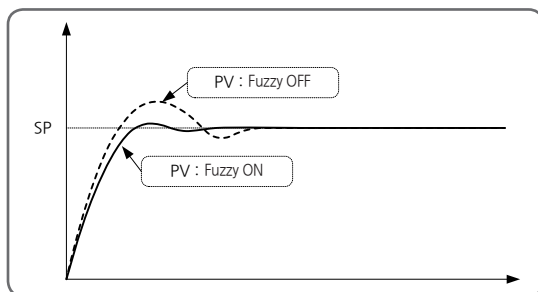

[Fig.9] Deterrence of Overshoot by Fuzzy Function



NOTE

Fuzzy Operation

- When the variation of load power is great, or SP is changed frequently, overshooting appears generally. The Fuzzy function is effective to suppress the overshooting.
- Internal working sequence of Fuzzy function
 - ① When PV approaches SP, The calculation of Super SP is carried out.
 - ② Assuming this Super SP as SP, MV is estimated.
- Overshooting is suppressed by Fuzzy function.

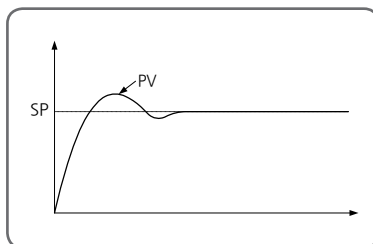

[Fig.10] Fuzzy OFF

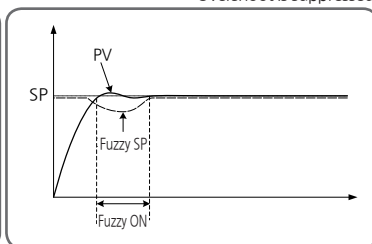

[Fig.11] Fuzzy ON

☞ Overshoot is suppressed

5.3.4. PID Number Setting

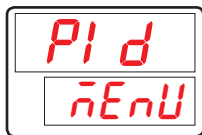

- Parameter for selecting one of four PID group numbers.

Symbol	Parameter	Setting range	Unit	Default	Display
PID	PID Number	MENU, 1 ~ 4	ABS	MENU	Always

5.3.5. Proportional Band Setting



- Parameter for setting proportional band operation for PID control.

Symbol	Parameter	Setting range	Unit	Default	Display
#n.P	Heat Proportional Band	0.1 ~ 1000.0% H/C : 0.0(ON/OFF Control), 0.1 ~ 1000.0%	%	10.0	Always

#n = 1~4

5.3.6. Integration Time Setting



- Parameter for setting integration time for PID control.

Symbol	Parameter	Setting range	Unit	Default	Display
#n.I	Heat Integral Time	OFF, 1 ~ 6000 sec	ABS	120 sec	Always

#n = 1~4

5.3.7. Derivation Time Setting



- Parameter for setting derivative time for PID control.

Symbol	Parameter	Setting range	Unit	Default	Display
#n.D	Heat Derivative Time	OFF, 1 ~ 6000 sec	ABS	30 sec	Always

#n = 1~4

5.3.8. Manual Set Value Of Integration Time Setting



- Parameter for applying manually set value to PID calculation integration time, provided that integration time (I) is off.
- Set values in 1.MR(Manual Reset) will be apply for settings other than off.

Symbol	Parameter	Setting range	Unit	Default	Display
#n.MR	Manual Reset	-5.0 ~ 105.0%	%	50.0%	I = 0, H/C Type

#n = 1~4

5.3.9. Proportional Band (Cooling Control) Setting

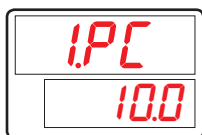

- Parameter for setting p-band operation for cooler PID control in H/C type.

Symbol	Parameter	Setting range	Unit	Default	Display
#n.PC	Cool Proportional Band	0.0(ON/OFF Control), 0.1 ~ 1000.0%	%	10.0	H/C Type

#n = 1~4

5.3.10. Integration Time (Cooling Control) Setting



- Parameter for setting integration time for cooler PID control H/C type.

Symbol	Parameter	Setting range	Unit	Default	Display
#n.IC	Cool Integral Time	OFF, 1 ~ 6000 sec	ABS	120 sec	H/C Type

#n = 1~4

5.3.11. Derivation Time (Cooling Control) Setting



- Parameter for setting derivative time for cooler PID control H/C type.

Symbol	Parameter	Setting range	Unit	Default	Display
#n.DC	Cool Derivative Time	OFF, 1 ~ 6000 sec	ABS	30 sec	H/C Type

#n = 1~4

5.3.12. Heater And Cooler Dead Band Setting



- Parameter for setting heater and cooler dead bands in H/C type.

Symbol	Parameter	Setting range	Unit	Default	Display
#n.DB	Dead Band	-100.0 ~ 15.0%	%	3.0%	H/C Type

#n = 1~4

5.3.13. PID Zone Setting



- Parameter for setting the 3 PID zones in controller.

- PID is applied by RP setting.

PID1 : IN.RL (IN.SL if input mV, V sensor) ~ 1.RP

PID2 : 1.RP~2.RP

PID3 : 3.RP~IN.RH(IN.SH if input mV, V sensor)

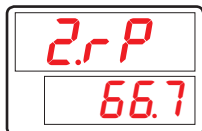

Symbol	Parameter	Setting range	Unit	Default	Display
1.RP	Reference Point1	EU(0.0%) ≤ 1.RP ≤ 2.RP	EU	EU(33.3)	PID = 1
2.RP	Reference Point2	1.RP ≤ 2.RP ≤ EU(100.0%)	EU	EU(66.7%)	PID = 2

5.3.14. PID Hysteresis Setting



- Parameter for setting Hysteresis when select a PID group in sectional PID.

Symbol	Parameter	Setting range	Unit	Default	Display
RP.HY	Reference Hysteresis	EUS(0.0 ~ 10.0%)	EUS	EUS(0.3%)	PID = 3

5.3.15. Deviation Value Setting

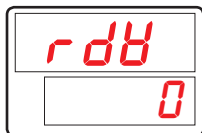

- Parameter for setting deviation if using deviation PID.

Symbol	Parameter	Setting range	Unit	Default	Display
RDV	Reference Deviation	EUS(0.0 ~ 100.0%)	EUS	EUS(0.0%)	PID = 4



PID Group

- PID Zone is determined by NPV. When PV oscillates around the zone boundaries 1.RP, 2.RP, PID set changes correspondingly. To prevent frequent change of PID set, the RP.HY can be set.

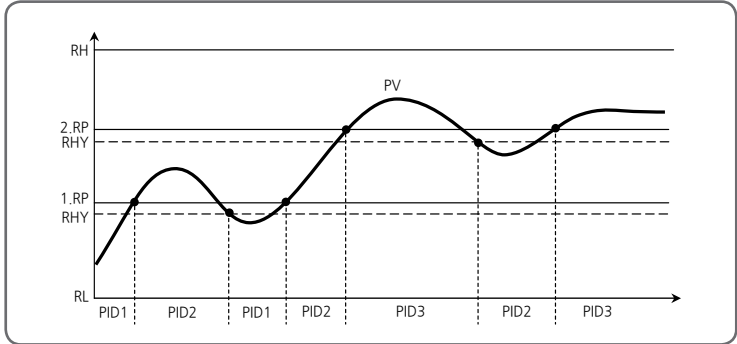

- Deviation PID (4.PID) may be used by setting RDV value. When $|PV-SP| > RDV$, 4.PID set is applied.

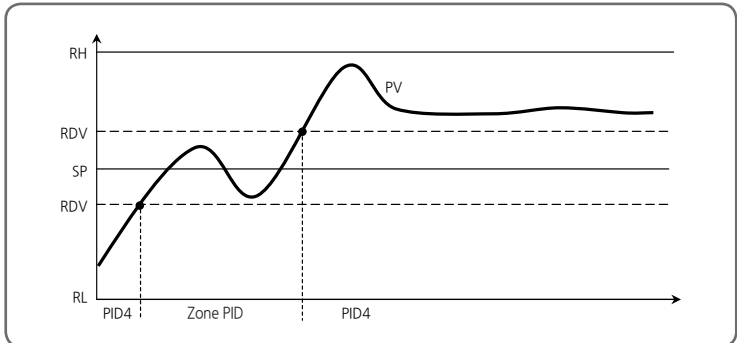



Example of Heating / Cooling

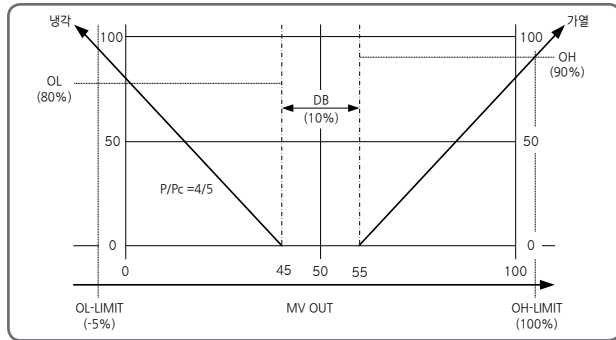

[Fig.12] Heating and Cooling under PID Control

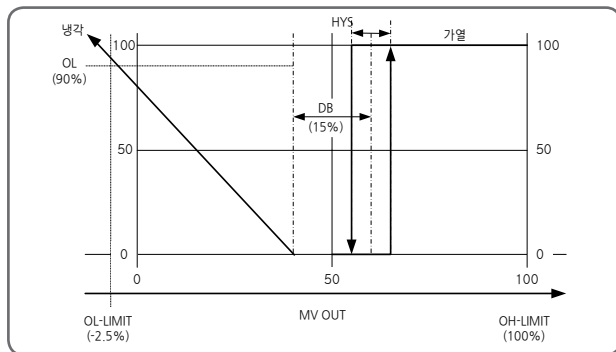

[Fig.13] Heating = ON / OFF, Cooling = PID Control

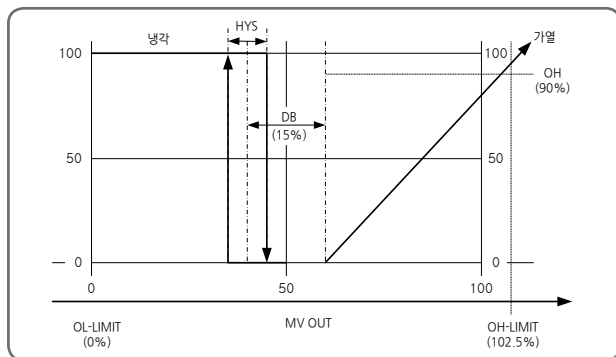

[Fig.14] Heating = PID Control, Cooling = ON / OFF

5.4. Control Functions Group(G.CTL)

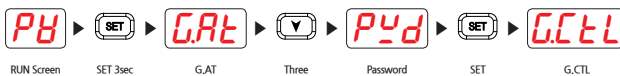
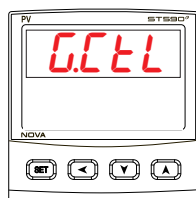

- Parameter for setting control parameters.

5.4.1. Power Mode Setting



- Parameter for setting ON/OFF mode.
- STOP : Stops when power is on.
- COLD : Operates on RUN when power is on.
(If S-TM is set, it operates as set in reservation run.)
- HOT : Maintains power off status. (Restarts at P-time.)

Symbol	Parameter	Setting range	Unit	Default	Display
PWR.M	Power Mode	STOP, COLD, HOT	ABS	COLD	Always

5.4.2. Process Timer Operation Mode Setting



- Parameter for setting process timer operation mode.
- PV.SP : After RUN, P-TM will proceed from PV = SP.
- S-TM : After S-TM operation, P-TM will proceed.

Symbol	Parameter	Setting range	Unit	Default	Display
PTO.M	Process Timer Operation Mode	PV.SP, S-TM	ABS	PV.SP	Always

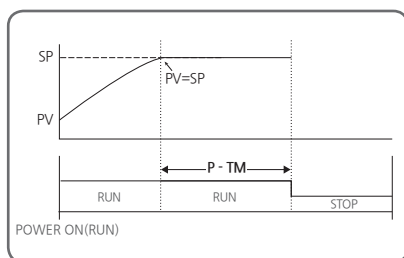

[Fig.15] PV=SP Mode Operation

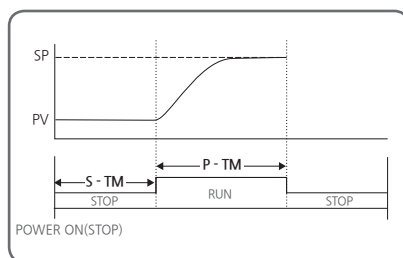

[Fig.16] S-TM Mode Operation

5.4.3. Reservation RUN Setting

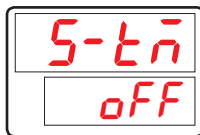

- Parameter for setting waiting time from power on to operation.
- '⌚' Lamp is turned off when under reservation run.
(Refer to [Fig.17] Reservation Run Function)

Symbol	Parameter	Setting range	Unit	Default	Display
S-TM	Start Time	OFF, 0.01 ~ 99.59 min	TIME	OFF	Always

5.4.4. Run Time Setting

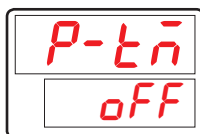

- Parameter for setting run time.
- '⌚' Lamp is turned on when under reservation run.
(Refer to [Fig.17] Reservation Run Function)

Symbol	Parameter	Setting range	Unit	Default	Display
P-TM	Process Time	OFF, 0.01 ~ 99.59 min	TIME	OFF	Always

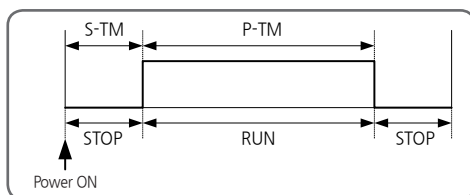

[Fig.17] Reservation Run Function

5.4.5.. Auto/Man Control Setting



- Parameter for setting In order to control the status of the regulator automatically (AUTO) or manual (MAN).
- If set at MAN, the MAN lamp located on the front display is turned on and able to set control output value.

Symbol	Parameter	Setting range	Unit	Default	Display
A/M	Auto/Man Control	AUTO, MAN	ABS	AUTO	Always

5.4.6. Valve Auto/Man Control Setting



- Parameter for setting for position proportional control, the valve output status is set to automatically(AUTO) or manual(MAN).
- When the V.A/M is set to Manual(MAN), the 'MAN' indicator on the front display will light. The EV1(Open)/EV2(Close) relay will also operate during the operation of the Up/Down key.

Symbol	Parameter	Setting range	Unit	Default	Display
V.A/M	Valve Auto/Man Control	AUTO, MAN	ABS	AUTO	Position proportional control

5.4.7. User Screen Setting



- Parameter for setting user screen to display most frequently used parameters on screen.
- Refer to Communication Manual D-Register to input.



Symbol	Parameter	Setting range	Unit	Default	Display
US1	User Screen1	OFF, D-Register No.(0001 ~ 1299)	ABS	OFF	Always
US2	User Screen2	OFF, D-Register No.(0001 ~ 1299)	ABS	OFF	Always

5.4.8. Key Lock Setting



- Parameter to counteract irregular operations due to erroneous input keys.
- If LOCK is ON, all parameter settings become restricted including SP.

Symbol	Parameter	Setting range	Unit	Default	Display
LOCK	Key Lock	OFF, ON	ABS	OFF	Always

5.4.9. External Contact Input(DI) Setting

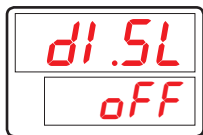

- Parameter for setting operation status of controller by External Contact Input (DI) Option.
(Refer to [Table1] DI Operation for controller operation under DI.SL setting.)

Symbol	Parameter	Setting range	Unit	Default	Display
DI.SL	DI Selection	OFF, 1, 2, 3	ABS	OFF	DI Option

[Table1] DI Operation

DI.SL	DI1	DI2	Operation
OFF	-	-	OFF
1	off	-	STOP
	on	-	RUN
	-	off	SP1
	-	on	SP2
2	off	off	SP1
	on	off	SP2
	off	on	SP3
	on	on	SP4
3	on	-	RUN (Timer Trigger)
	-	on	RUN (Timer Trigger)



Timer Trigger

- Pertinent timer is started if DI1 and 2 begin to run.
- For more details, refer to 5.9. Timer Group(G.TMR)

5.4.10. Output Status Display Setting



- Parameter for displaying current output setting (OUT1/2, EV1/2/3/4) of controller.
- You can check current output setting by turning on O.STS.

Symbol	Parameter	Setting range	Unit	Default	Display
O.STS	Output Status	OFF, ON	ABS	OFF	Always

5.4.11. PV Display High/Low Limit Setting



- Parameter for setting high/low limits of sensor input values on PV screen.
- Only values on and within DSP.H / DSP.L will be displayed on PV screen, although exceeding values are input from the sensor.
- However, the controller will operate according to the actual sensor values.

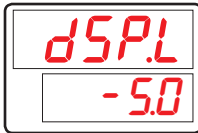

Symbol	Parameter	Setting range	Unit	Default	Display
DSP.H	Display High Limit	EU(-5.0 ~ 105.0%) (DSP.L < DSP.H)	EU	EU(105.0%)	Always
DSP.L	Display Low Limit		EU	EU(-5.0%)	Always

5.4.12. Password Setting



- Parameter for setting controller password.
- Once U.P.WD is set, password must be entered to access Control Group (G.CTL). If you set a password and input values do not match, you can not enter the parameters of the group in the future.
- Default U.P.WD password is '0'.

Symbol	Parameter	Setting range	Unit	Default	Display
U.P.WD	User Password	0 ~ 9999	ABS	0	Always



- Do not forget your password.
- If the password is misplaced, the unit is inaccessible by users. Please send the unit to our service department.

5.4.13. ON/OFF Mode Setting

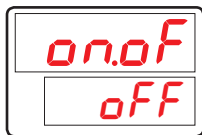

- Parameter for setting the use of ON/OFF mode.
- Once set, EV1 (Relay) is used as control output.

Symbol	Parameter	Setting range	Unit	Default	Display
ON.OF	ON/OFF Mode	OFF, ON	ABS	OFF	Always

5.4.14. Initialization of The Controller

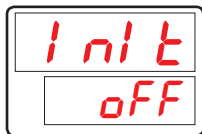

- Parameter for initiating controller.
- All controller parameters are initialized by switching INIT to ON. (However, communication and A/M are not initialized.)

Symbol	Parameter	Setting range	Unit	Default	Display
INIT	Parameter Initialization	OFF, ON	ABS	OFF	Always



Switching INIT to ON will initialize all controller parameters to default settings. Please be careful.

5.5. Input Group(G.IN)

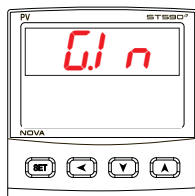

- Group of input parameters.

- ⇒ Input Type (IN-T) : Thermocouple (TC), Resistive thermal detector (RTD), DC volt (DCV).
- ⇒ In case of TC or RTD, the sensor type and temperature range should be selected.
- ⇒ In case of DCV, the input types are classified with the range of input voltage.



Input Group parameter settings must be adjusted first as they can influence initialization of other group parameters.

5.5.1. Input Type Setting

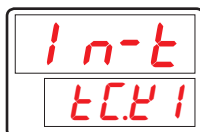

- Parameter for setting sensor input types.
- Refer to [Table2] Sensor input types to adjust settings.

Symbol	Parameter	Setting range	Unit	Default	Display
IN-T	Input Sensor Type	For more detail, refer to [Table2] Sensor input types	ABS	TC.K1	Always

5.5.2. Input Unit Setting

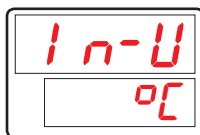

- Select “C” or “F” for input unit .
- Changing IN-U will automatically convert temperature ranges in appropriate unit.
- IN-U is only applicable when sensor type (IN-T) is TC or RTD.
- Refer to [Table2] Sensor input types to check temperature settings.

Symbol	Parameter	Setting range	Unit	Default	Display
IN-U	Input Unit	°C, °F	ABS	°C	IN-T = TC or RTD



Once sensor type is changed, all parameters are initialized, except for communication and A/M. Please be careful.

[Table2] Sensor input types

* Display range : -5% ~ +105%

Group	Symbol	Temp.Range(°C)	Temp.Range(°F)	Measurement Range
T/C	TC.K1	-200 ~ 1370	-300 ~ 2500	Range $\pm 0.1\% \pm 1$ digit for temperature greater than 0°C Range $\pm 0.2\% \pm 1$ digit for temperature less than 0°C
	TC.K2	-200.0 ~ 1370.0	-300.0 ~ 1900.0	
	TC.J	-200.0 ~ 1200.0	-300.0 ~ 1900.0	
	TC.E	-200.0 ~ 1000.0	-300.0 ~ 1800.0	
	TC.T	-200.0 ~ 400.0	-300.0 ~ 750.0	
	TC.R	0.0 ~ 1700.0	32 ~ 3100	Temperature range $\pm 0.15\% \pm 1$ digit
	TC.B	0.0 ~ 1800.0	32 ~ 3300	Range $\pm 0.15\% \pm 1$ digit for temperature greater than 400°C Range $\pm 5\% \pm 1$ digit for temperature less than 400°C
	TC.S	0.0 ~ 1700.0	32 ~ 3100	Temperature range $\pm 0.15\% \pm 1$ digit
	TC.L	-200.0 ~ 900.0	-300 ~ 1600	Range $\pm 0.1\% \pm 1$ digit for temperature greater than 0°C Range $\pm 0.2\% \pm 1$ digit for temperature less than 0°C
	TC.N	-200.0 ~ 1300.0	-300 ~ 2400	Range $\pm 0.1\% \pm 1$ digit for temperature greater than 0°C Range $\pm 0.25\% \pm 1$ digit for temperature less than 0°C
	TC.U	-200.0 ~ 400.0	-300.0 ~ 750.0	Range $\pm 0.1\% \pm 1$ digit for temperature greater than 0°C Range $\pm 0.2\% \pm 1$ digit for temperature less than 0°C
	TC.W	0 ~ 2300	32 ~ 4200	Temperature range $\pm 0.2\% \pm 1$ digit
TC.PL	0.0 ~ 1390.0	32 ~ 2500	Temperature range $\pm 0.1\% \pm 1$ digit	
TC.C	0 ~ 2320	32 ~ 4200	Temperature range $\pm 0.2\% \pm 1$ digit	
RTD	PTA	-200.0 ~ 850.0	-300.0 ~ 1560.0	Temperature range $\pm 0.1\% \pm 1$ digit
	PTB	-200.0 ~ 500.0	-300.0 ~ 1000.0	
	PTC	-50.00 ~ 150.00	-148.0 ~ 300.0	Inquire separately
	PTD	-200 ~ 850	-300 ~ 1560	Temperature range $\pm 0.1\% \pm 1$ digit
	JPTA	-200.0 ~ 500.0	-300.0 ~ 1000.0	Temperature range $\pm 0.1\% \pm 1$ digit
	JPTB	-50.00 ~ 150.00	-148.0 ~ 300.0	Inquire separately
DCV	2V	0.400 ~ 2.000V(-10000 ~ 19999)		Temperature range $\pm 0.1\% \pm 1$ digit
	5V	1.000 ~ 5.000V(-10000 ~ 19999)		
	10V	0.00 ~ 10.00V(-10000 ~ 19999)		
	20MV	-10.00 ~ 20.00mV(-10000 ~ 19999)		
	100MV	0.0 ~ 100.0mV(-10000 ~ 19999)		

* Performance at standard operating status at 23 \pm 2°C, 55 \pm 10%RH, and 50/60Hz* When receiving 4~20mA DC signal, select DCV 5V (1~5V DC) and connect 250 Ω resistance.

[Table3] Sensor input types(ST510[®])

* Display range : -5% ~ +105%

Group	Symbol	Temp.Range(°C)	Temp.Range(°F)	Measurement Range
T/C	TC.K1	-200~1370	-300~2500	Range $\pm 0.1\% \pm 1$ digit for temperature greater than 0°C Range $\pm 0.2\% \pm 1$ digit for temperature less than 0°C
	TC.K2	-199.9~999.9	0~2300	
	TC.J	-199.9~999.9	-300~2300	
	TC.E	-199.9~999.9	-300~1800	
	TC.T	-199.9~400.0	-300~750	
	TC.R	0~1700	32~3100	Temperature range $\pm 0.15\% \pm 1$ digit
	TC.B	0~1800	32~3300	Range $\pm 0.15\% \pm 1$ digit for temperature greater than 400°C Range $\pm 5\% \pm 1$ digit for temperature less than 400°C
	TC.S	0~1700	32~3100	Temperature range $\pm 0.15\% \pm 1$ digit
	TC.L	-199.9~900.0	-300~1600	Range $\pm 0.1\% \pm 1$ digit for temperature greater than 0°C Range $\pm 0.2\% \pm 1$ digit for temperature less than 0°C
	TC.N	-200~1300	-300~2400	Range $\pm 0.1\% \pm 1$ digit for temperature greater than 0°C Range $\pm 0.25\% \pm 1$ digit for temperature less than 0°C
	TC.U	-199.9~400.0	-300~750	Range $\pm 0.1\% \pm 1$ digit for temperature greater than 0°C Range $\pm 0.2\% \pm 1$ digit for temperature less than 0°C
	TC.W	0~2300	32~4200	Temperature range $\pm 0.2\% \pm 1$ digit
	TC.PL	0~1390	32~2500	Temperature range $\pm 0.1\% \pm 1$ digit
TC.C	0~2320	32~4200	Temperature range $\pm 0.2\% \pm 1$ digit	
RTD	PTA	-199.9~850.0	-300~1560	Temperature range $\pm 0.1\% \pm 1$ digit
	PTB	-199.9~500.0	-199.9~999.9	
	PTC	-19.99~99.99	-4.0~212.0	Inquire separately
	PTD	-199.9~850.0	-300~1560	Temperature range $\pm 0.1\% \pm 1$ digit
	JPTA	-199.9~500.0	-199.9~999.9	Temperature range $\pm 0.1\% \pm 1$ digit
	JPTB	-150.0~150.0	-199.9~300.0	Inquire separately
DCV	2V	0.400 ~ 2.000V(-1999 ~ 9999)		Temperature range $\pm 0.1\% \pm 1$ digit
	5V	1.000 ~ 5.000V(-1999 ~ 9999)		
	10V	0.00 ~ 10.00V(-1999 ~ 9999)		
	20MV	-10.00 ~ 20.00mV(-1999 ~ 9999)		
	100MV	0.0 ~ 100.0mV(-1999 ~ 9999)		

^① Performance at standard operating status at 23±2°C, 55±10%RH, and 50/60Hz^② When receiving 4~20mA DC signal, select DCV 5V (1~5V DC) and connect 250 Ω resistance.

5.5.3. Input Range Setting



- Parameter for setting high/low limits for sensor input.
- TC, RTD Input
Once sensor type is selected, input range for TC and RTD will be determined according to [Table2] **Sensor input types**.
Input ranges for IN.RH and IN.RL can be changed within given range.
Decimal placement cannot be changed.
- DCV, mV Input
Determining input range after selecting a sensor type is the same for voltage input. Input ranges for IN.RH and IN.RL can be changed within given range.

Symbol	Parameter	Setting range	Unit	Default	Display
IN.RH	Input Range High	Refer to [Table2] Sensor input types within Input type. (IN.RH > IN.RL)	EU	EU(100%)	Always
IN.RL	Input Range Low		EU	EU(0.0%)	Always



NOTE

Input Range Setting Example

- When using a range of [Table2] **Sensor input types** to select the thermocouple input range of -200 ~ 1370 °C hereafter, setting "500" to "-100", Low Range High Range setting items on the setting items, -100 ~ 500 °C this is limited.

5.5.4. Decimal Point Setting



- Parameter for setting decimal placement, if sensor input type is mV or V.

Symbol	Parameter	Setting range	Unit	Default	Display
IN.DP	Input Dot Position	0~3	ABS	1	IN-T = DCV



CAUTION

Changing this parameter will change decimal placement for all parameters pertinent to PV, including those relevant to EU and EUS.

5.5.5. PV Display Range Setting

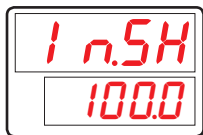

- Parameter for setting high limit for scale, if sensor input type is mV or V.

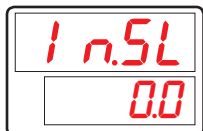

- Parameter for setting low limit for scale, if sensor input type is mV or V.

Symbol	Parameter	Setting range	Unit	Default	Display
IN.SH	Input Scale High	- 10000~19999, but INSH > INSL	ABS	100.0	IN-T = DCV
IN.SL	Input Scale Low	Decimal place will conform to IN.DP		0.0	IN-T = DCV



PV Display Range Setting Example

- Select the input voltage(V, mV) to the input type, and the range is 1~5V and scaled display need to be 0~100 IN-T : 5V.
- IN.SH : 100(5V input is scaled to "100" display).
- IN.SL : 0(1V input is scaled to "0" display).

5.5.6. Input Filter Setting

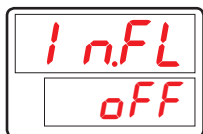

- Parameter for setting PV filter to moderate PV run-outs due to disturbance and noise.

Symbol	Parameter	Setting range	Unit	Default	Display
IN.FL	Input Sensor Filter	OFF, 1 ~ 120	ABS	OFF	Always

5.5.7. Display Filter Setting



- Parameter for moderating PV run-outs due to delicate sensor reaction under normal operation.

Symbol	Parameter	Setting range	Unit	Default	Display
D.FL	Display Filter	OFF, 1~120	ABS	OFF	Always

5.5.8. PV Direction Setting During Sensor-Open

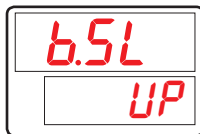

- Parameter for setting sensor direction during sensor-open.
- If B.SL value is UP, PV will operate upwards of sensor input. If B.SL value is DOWN, PV will operate downwards of sensor input.
- B.SL default setting is UP. (However, when input mV and V, it will be initialized to OFF. 10V, 20mV and 100mV will not be S.OPN checked.)

Symbol	Parameter	Setting range	Unit	Default	Display
B.SL	Burn Out Select (Note1)	OFF, UP, DOWN	ABS	UP (DCV=OFF)	Always

* (Note1) : S.OPN(Sensor-Open) = B.OUT(Burn-Out)

5.5.9. Reference Junction Compensation Setting

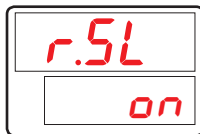

- Parameter for setting use of RJC (Reference Junction Compensation), in case the sensor input type is TC (thermocouple).

Symbol	Parameter	Setting range	Unit	Default	Display
R.SL	RJC Select	ON, OFF	ABS	ON	IN-T = TC

5.5.10. All Bias Setting

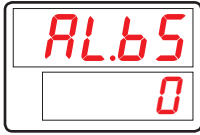

- Adjusts offsets of all bias values for PV display.
- PV display value = input value + all bias (AL.BS).

Symbol	Parameter	Setting range	Unit	Default	Display
AL.BS	All Bias Value	EUS(-100.0 ~ 100.0%)	EUS	EUS(0.0%)	Always

5.5.11. Piece Bias Setting

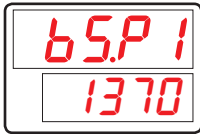

- Parameter for setting piece bias to set BIAS to PV value.
- Up to 4 references can be set for bias.
 - Reference 1 : IN,RL(IN,SL) ↔ BS,P1
 - Reference 2 : BS,P1 ↔ BS,P2
 - Reference 3 : BS,P2 ↔ BS,P3
 - Reference 4 : BS,P3 ↔ IN,RH(IN,SH)
- For more details, refer to [Fig.18] Example of Piece Bias and [Fig.19] Example of Piece Bias Formula .

Symbol	Parameter	Setting range	Unit	Default	Display
BS.P#n	Reference Bias Point	EU(0.0 ~ 100.0%) IN,RL ≤ BS,P1 ≤ BS,P2 ≤ BS,P3 ≤ IN,RH	EU	EU(100.0%)	Always

#n = 1~3



- Parameter for setting the PV value correction value(BIAS) to be applied to domestic correction.
- For more details, refer to [Fig.18] Example of Piece Bias and [Fig.19] Example of Piece Bias Formula .

Symbol	Parameter	Setting range	Unit	Default	Display
BS#n	Bias Value for BS,P Point	EUS(-100.0 ~ 100.0%)	EUS	0	Always

#n = 0~4



Example of Piece Bias

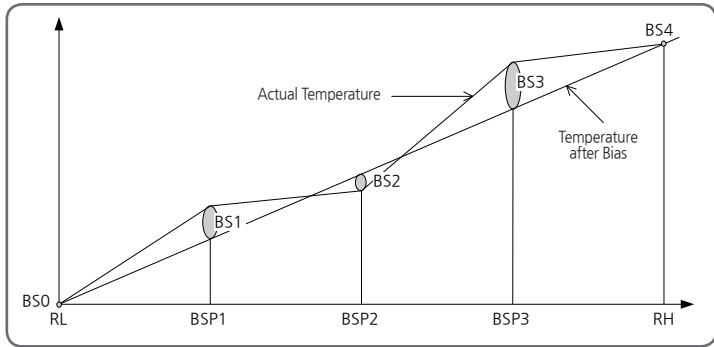

[Fig.18] Example of Piece Bias

- There are +2°C in 25°C, -1°C in 50°C, +3°C in 75°C as temperature deviation in measuring actual temperature in range from 0°C ~100°C, and try to take a Piece Bias, each Bias set value are shown as follows.

RL = 0°C, BSP1=25°C, BSP2=50°C, BSP3=75°C, RH=100°C

BS0 = 0°C, BS1=-2°C, BS2=+1°C, BS3=-3°C, BS4=0°C

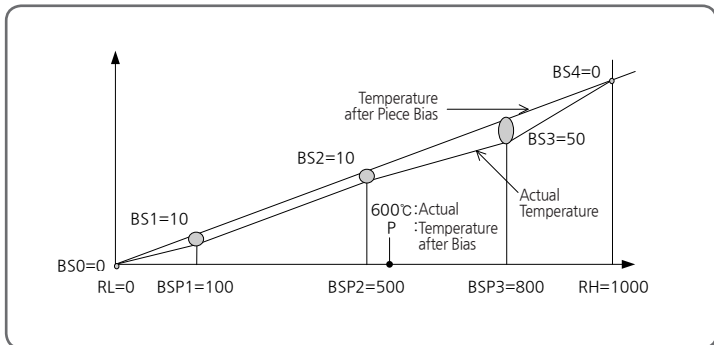

[Fig.19] Example of Piece Bias Formula

- Temperature Bias Value = Temperature after Bias - Actual Temperature
- Temperature in 600°C(P) after Bias

$$P = 600 + (600 - \text{BPS2}) \times \frac{\text{BS3} - \text{BS2}}{\text{BSP3} - \text{BSP2}} + \text{BS2}$$



NOTE

Processing PV Input

- If PV is less than EU(-5%) or greater than EU(-105%), PV will be -OVR or OVR.
- For internal operation, PV will be set -5%, 105% .
 - $PV > EU(105\%)$: PV = 105%, PV = OVR
 - $EU(-5\%) \leq PV \leq EU(105\%)$: PV = PV
 - $PV < EU(-5\%)$: PV = -5%, PV = -OVR

-
- All parameters are reset to change the sensor types.
(However, communication and A/M are not initialized.)
 - If you change the input type and input range, so the parameters, that is unit related to the input range is changed according to the EU or EUS parameters are input range should be set ahead of the sensor type parameter with units of the EU or EUS.



CAUTION

- **Setting Example**
 - Pt100 Ω sensor is used in the range of -50.0~500.0 $^{\circ}$ C and display 1 decimal place.
 - IN-T = PTA \rightarrow PTA (-200.0~850.0 $^{\circ}$ C range) uses a pressure sensor.
 - IN-U = $^{\circ}$ C \rightarrow Display unit is $^{\circ}$ C.
 - IN.RH = 500.0
 - IN.RL = -50.0

5.6. Control Output Group(G.OUT)

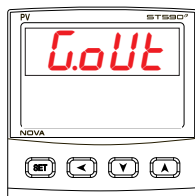

- Group of output parameters.

⇒ Output type will be selected according to parameter setting of OUT1, OUT2, EV1, EV2, EV3 and EV4 of G.OUT.

⇒ Output methods OUT1 and OUT2 support SSR/SCR, and EV1, EV2, EV3 and EV4 are a relay.

[Table4] Output Types

OUTPUT	SSR/SCR		Relay			
	OUT1	OUT2	EV1	EV2	EV3	EV4
Control Output (Heating)	○	○	○	○	○	○
Control Output (Cooling)	○	○	○	○	○	○
Position Proportional Control Open			○			
Position Proportional Control Close				○		
Alarm Signal 1, 2, 3 and 4			○	○	○	○
RUN Signal			○	○	○	○
Inner Signal 1 and 2			○	○	○	○
LBA, TMR1 and 2			○	○	○	○
Transmission Output	○	○				

5.6.1. Output Types Setting



- Parameter for setting operation of OUT1.



- Parameter for setting operation of OUT2.

Symbol	Parameter	Setting range	Unit	Default	Display
OUT1	Analog Output 1	HEAT, RET	ABS	HEAT	Always
OUT2	Analog Output 2	H/C : COOL, HEAT, RET	ABS	RET	Always

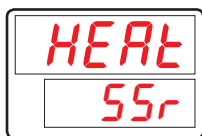

- Parameter for setting output types, when OUT1 or OUT2 is set at HEAT.

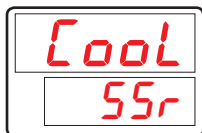

- Parameter for setting output types, when OUT1 or OUT2 is set at COOL.

Symbol	Parameter	Setting range	Unit	Default	Display
HEAT	Heat Output Type	SSR, SCR	ABS	SSR	OUT1, OUT2 = HEAT
COOL	Cool Output Type		ABS	SSR	OUT1, OUT2 = COOL



- Parameter for setting Event Output EV1~4 (relay output).
- EV3 and 4 parameters are displayed as 'Option'.

Symbol	Parameter	Setting range	Unit	Default	Display
EV1	Event Output 1 (Note1)	COOL, HEAT, ALM1, ALM2, ALM3, ALM4, RUN, IS1, IS2, LBA, TMR1, TMR2	ABS	ALM1	Always
EV2	Event Output 2 (Note2)		ABS	ALM2	Always
EV3	Event Output 3		ABS	ALM3	Option
EV4	Event Output 4		ABS	ALM4	Option

* (Note 1) : The position proportional control, EV1 OPEN output is fixed.

* (Note 2) : When position proportional control, EV2 CLOSE output is fixed.



Example of Output Setting

- Control Output (OUT1 → SSR), Transmission Output (OUT2 → RET),
Relay Output (EV1 → ALM1, EV2 → ALM2, EV3 → ALM3, EV4 → ALM4)

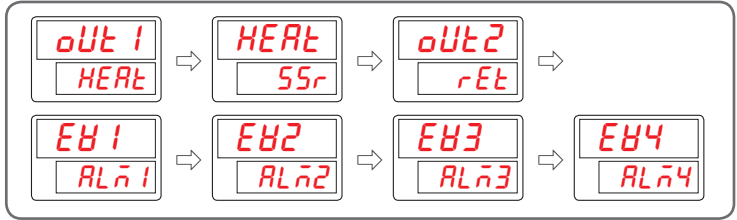

[Fig.20] Example of Output Setting

5.6.2. Output Direction Setting



- Parameter for setting normal / reverse direction of control output.
- If O.ACT is set REV and PV is less than SP, control output is increased and vice versa if O.ACT is set FWD.

Symbol	Parameter	Setting range	Unit	Default	Display
O.ACT	Output Direction Actuator	REV, FWD	ABS	REV	Always



Forward and Reverse Control Action

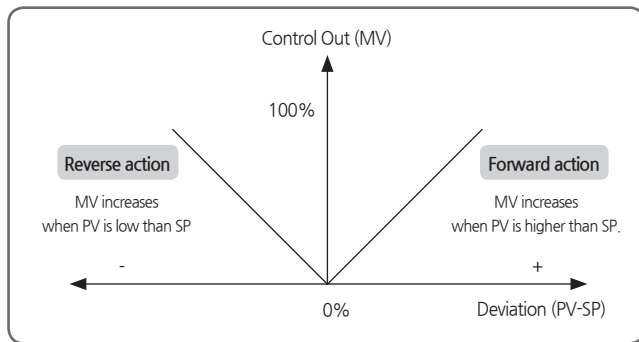

[Fig.21] Forward and Reverse Control Action

5.6.3. Output Cycle Setting

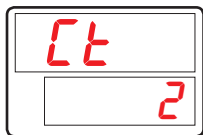

- Parameter for setting time for one ON/OFF cycle, if control output is set proportional to PID control time (i.e. OUT1 or 2 = HEAT (SSR), EV1~4 = HEAT).



- Parameter for setting time for one ON/OFF cycle, if H/C type is set proportional to PID control time (i.e. OUT1 or 2 = COOL (SSR), EV1~4 = COOL).

Symbol	Parameter	Setting range	Unit	Default	Display
CT	Heat Cycle Time	1 ~ 300 sec	ABS	2 sec	Always
CTC	Cool Cycle Time	1 ~ 300 sec	ABS	2 sec	H/C Type



NOTE

Cycle Time

- Cycle time is valid only when output type is SSR (Solid State Relay) or RELAY.
- Cycle time is 1 period of ON + OFF time.
- In case the cycle time is 10 sec. (CT = 10)

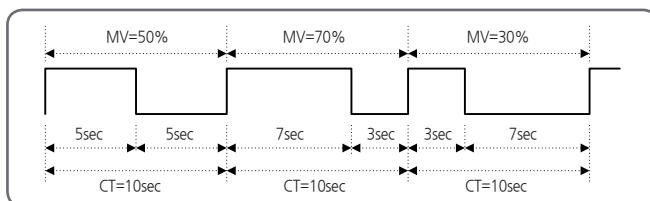

[Fig.22] In case the cycle time is 10 sec (CT = 10)

5.6.4. Valve Control Mode Setting

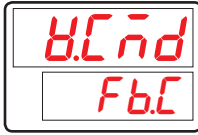

- Parameter for setting the valve control mode during position proportional control.
- FB.C : Receive feedback input (resistance) to display valve position and control.
- FB.VC : Receive feedback input (resistance) to display the valve position and control, when the feedback input disconnection to the virtual control mode. When converted to the virtual control mode, the decimal point '.' in the operating screen V.*** will flash.
- VRT.C : No feedback input to virtual control valve position determination.

Symbol	Parameter	Setting range	Unit	Default	Display
V.CMD	Valve Control Mode	FB.C (Feed back control), FB.VC (Feed back & Virtual control) VRT.C (Virtual control)	ABS	FB.C	Position proportional control, Input feedback

5.6.5. Valve Calibration(AUTO) Setting



- Parameter for setting the valve upper/ lower limit position to automatically adjust during position proportional control.
- When automatic adjustment is performed, adjustment is started after V.CAL is displayed on the operation screen.
- At the beginning of the auto-tuning, if there is no change in the feedback input, V.CER is displayed and the adjustment is ended. When V.CER is displayed, the valve output is not executed.

Symbol	Parameter	Setting range	Unit	Default	Display
V.CAL	Valve Auto Calibration	OFF, ON	ABS	OFF	When FB.C or FB.VC is selected

5.6.6. Valve High/Low Position Calibration(MAN) Setting

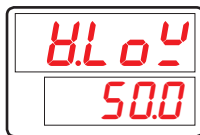

- Parameter for setting the valve lower limit position to manually adjust during position proportional control.
- The EV1(Open) and EV2(Close) relays will operate during pressing the Up / Down key. Press the SET key to store the current value of the lower limit position.
- Parameter for setting the valve upper limit position to manually adjust during position proportional control.
- The EV1(Open) and EV2(Close) relays will operate during pressing the Up / Down key. Press the SET key to store the current value of the upper limit position.

Symbol	Parameter	Setting range	Unit	Default	Display
V.LOW	Valve Low Position Calibration	V.VP Display : -5.0 ~ 105.0%	ABS	Current Value	During FB,C or FB,VC, V.CAL skips during operation
V.HI	Valve High Position Calibration	V.VP Display : -5.0 ~ 105.0%	ABS	Current Value	

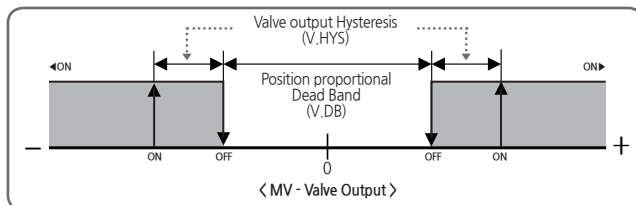

[Fig.23] Position proportional valve output operation

5.6.7. Valve Traveling Time Setting

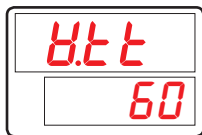

- Parameter for setting valve traveling time.

Symbol	Parameter	Setting range	Unit	Default	Display
V.TT	Valve Traveling Time	1 ~ 999 sec	ABS	60 sec	Position proportional control

5.6.8. Output High / Low Limit Setting



- Parameter for setting high output limit.

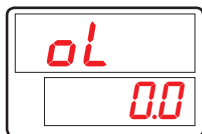

- Parameter for setting low output limit.
- Control output is restricted to high/low limit values.

Symbol	Parameter	Setting range	Unit	Default	Display
OH	Output High Limit H/C : Heat Output Limit	(OL + 1Digit) ~ 105.0% H/C : 0.0 ~ 105.0%	%	100.0%	Always
OL	Output Low Limit H/C : Cool Output Limit	-5.0% ~ (OH - 1Digit) H/C : 0.0 ~ 105.0%	%	0.0% H/C : 100.0%	Always

5.6.9. Output Process Rate Setting



- Parameter for setting output process rate, in second.

Symbol	Parameter	Setting range	Unit	Default	Display
OPR	Output Process Rate	OFF, 0.1 ~ 100.0%/sec	ABS	OFF	Always

5.6.10. Hysteresis Setting



- Parameter for setting Hysteresis, if control output is ON/OFF output in H/C type.



- Parameter for setting Hysteresis, if control output is valve output in Position Proportional Control.

Symbol	Parameter	Setting range	Unit	Default	Display
HYS	On/Off Hysteresis	0.0 ~ 10.0%	%	0.5%	H/C Type
V.HYS	Valve Hysteresis	0.0 ~ 100.0%	%	0.5%	Position proportional control

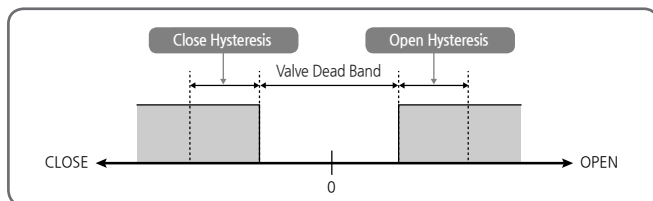

[Fig.24] V.DB and V.HYS Operation

5.6.11. Valve Dead Band Setting

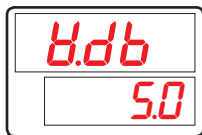

- Parameter for setting valve dead band in Position Proportional Control.



- Parameter for setting PV dead band in Position Proportional Control.



- Parameter for setting Hysteresis of PV dead band in Position Proportional Control.

Symbol	Parameter	Setting range	Unit	Default	Display
V.DB	Valve Dead Band	0.1 ~ 100.0%	%	3.0%	Position proportional control
V.P.DB	Valve PV Dead Band	EUS(0.0~100.0%)	EUS	EUS(0.0%)	Position proportional control
V.P.H.S	Valve PV Hysteresis	EUS(0.0 ~ 10.0%)	EUS	EUS(0.5%)	Position proportional control

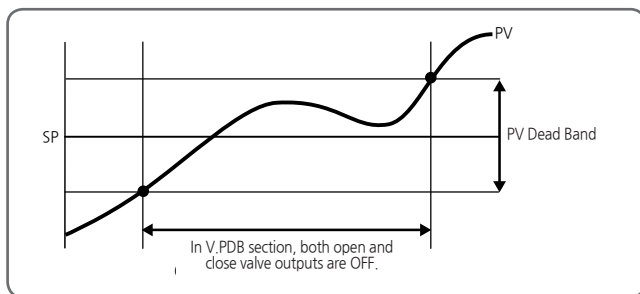

[Fig.25] V.P.DB (Valve PV Dead Band)

5.6.12. ON/OFF Mode Hysteresis Setting

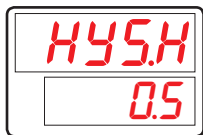

- Parameter for setting High Hysteresis in general ON/OFF mode.

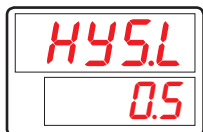

- Parameter for setting Low Hysteresis in general ON/OFF mode.

Symbol	Parameter	Setting range	Unit	Default	Display
HYS.H	On/Off High Hysteresis	EUS(0.0 ~ 10.0%)	EUS	EUS(0.5%)	ON,OF = ON
HYS.L	On/Off Low Hysteresis	EUS(0.0 ~ 10.0%)	EUS	EUS(0.5%)	ON,OF = ON



NOTE

ON/OFF Control

- In ON/OFF control mode, MV is 0% or 100% depending on (NPV - NSP) deviation.
- By setting ON/OFF Hysteresis, time average MV can be controlled.
- ON/OFF mode is valid when output type is RELAY or SSR.

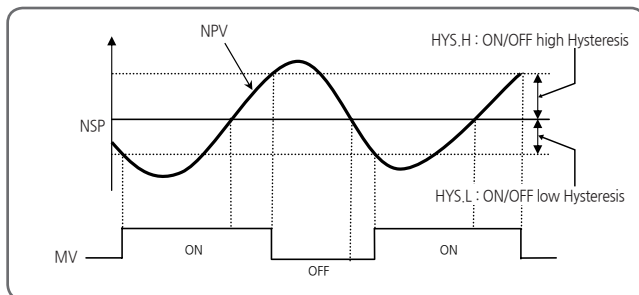

[Fig.26] ON/OFF Control

5.6.13. Emergency Output Setting

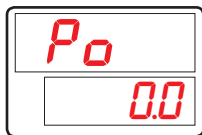

- Parameter for setting emergency output values.
- When stopped due to A/D error or sensor-open while in AUTO mode, the system discontinues output from PID calculation and begins to output valves set in Po.



- Parameter for setting emergency cool preset output values in H/C type.
- When stopped due to A/D error or sensor-open while in AUTO mode, the system discontinues output from PID calculation and begins to output valves set in Poc.

Symbol	Parameter	Setting range	Unit	Default	Display
PO	Heat Preset Output	-5.0 ~ 105.0% H/C : 0.0 ~ 105.0%	%	0.0%	Always
POC	Cool Preset Output	0.0 ~ 105.0%	%	0.0%	H/C Type

5.6.14. Output LED Setting

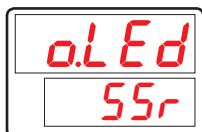

- Parameter for setting Output LED (MV OUT Lamp).
- SSR : MV lamp is turned off according to CT during SSR or relay control output.
- SCR : MV lamp is turned off irrelevant to CT during SCR control output.

Symbol	Parameter	Setting range	Unit	Default	Display
O.LED	Output LED	SSR, SCR	ABS	SSR	Always

5.7. Alarm Group(G,ALM)

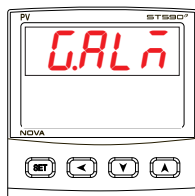

■ Group of alarm parameters

- ⇒ Output Direction mode
 - Forward : ON when alarm condition, OFF when alarm off
 - Reverse : OFF when alarm condition, ON when alarm off
- ⇒ The condition of Standby
 - Power On
 - Changing of Alarm Type
 - Changing SP

5.7.1. Alarm Type Setting



- Parameter for setting Alarm type.
- Refer to [Table4] Type of Alarm to see alarm types.

Symbol	Parameter	Setting range	Unit	Default	Display
ALT#n	Alarm Type	Refer to [Table4] Type of Alarm	ABS	AH.F	Always

#n = 1~4

5.7.2. Alarm Point Setting



- Parameter for setting alarm point with respect to alarm types set in ALT#n (presents during high/low limit operations).

Symbol	Parameter	Setting range	Unit	Default	Display
AL-#n	Alarm Set Value	EU(-100.0 ~ 100.0%)	EU	EU(100.0%)	Others deviation alarm

#n = 1~4

5.7.3. High/Low Deviation Alarm Setting

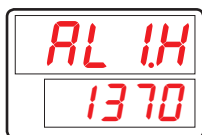

- Illustrates high alarm point within deviation bounds during high limit deviation operation.



- Illustrates high alarm point within deviation bounds during low limit deviation operation.

Symbol	Parameter	Setting range	Unit	Default	Display
AL#n.H	Alarm Set High Deviation	EUS(-100.0 ~ 100.0%)	EUS	EUS(0.0%)	Deviation alarm
AL#n.L	Alarm Set Low Deviation	EUS(-100.0 ~ 100.0%)	EUS	EUS(0.0%)	Deviation alarm

#n = 1~4

5.7.4. Hysteresis Setting

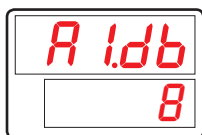

- Parameter for setting Alarm Hysteresis.

Symbol	Parameter	Setting range	Unit	Default	Display
A#n.DB	Alarm Hysteresis Value	EUS(0.0 ~ 100.0%)	EUS	EUS(0.5%)	Others soak alarm

#n = 1~4

5.7.5. Delay Time Setting

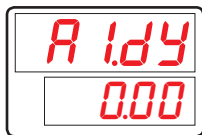

- Parameter for setting alarm output delay time during Alarm.

Symbol	Parameter	Setting range	Unit	Default	Display
A#n.DY	Alarm Delay Time	0.00 ~ 99.99 (mm.ss)	TIME	0 sec	Others soak alarm

#n = 1~4



Displays and Types of Alarms

- Output Type
 - Forward : ON when alarm is on, OFF when alarm is off
 - Reverse : OFF when alarm is on, ON when alarm is off
- Standby Condition
 - When power is on
 - When changed alarm type
 - When SP is modified

A diagram of a 5-digit display showing '1.0.0.0.0'. Each digit has a vertical line extending downwards from its base, representing a connection point for a specific alarm type.

Standby off : No Display
Standby on : Display 'S'

Forward : 'F' Display
Reverse : 'R' Display

All time indicate Decimal Point.

High-Limited : 'H' Display
Low-Limited : 'L' Display
Outside Range of Deviation : 'O' Display
Inside Range of Deviation : 'I' Display

Absolute Value Alarm : 'A' Display
Deviation Value Alarm : 'D' Display

5.7.6. Alarm Mode Setting

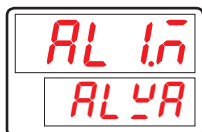

- Parameter for setting Alarm Mode
- ALWA : The alarm mode is always executed irrespective of the operation / stop.
- RUN : Alarm mode is only executed during operation.

Symbol	Parameter	Setting range	Unit	Default	Display
AL#n.M	Alarm #n Mode	ALWA, RUN	ABS	ALWA	Others soak alarm

#n = 1~4

[Table4] Type of Alarm

No.	Type	Output Direct		Standby		Display
		For	Rev	Off	On	
1	Upper of PV	○		○		AH,F
2	Lower of PV	○		○		AL,F
3	Upper of Deviation	○		○		DH,F
4	Lower of Deviation	○		○		DL,F
5	Upper of Deviation		○	○		DH,R
6	Lower of Deviation		○	○		DL,R
7	High/Low deviation out of range	○		○		DO,F
8	High/Low deviation within of range	○		○		DI,F
9	Upper of PV		○	○		AH,R
10	Lower of PV		○	○		AL,R
11	Upper of Valve **	○		○		VH,F
12	Lower of Valve **	○		○		VL,F
13	Upper of PV	○			○	AH,FS
14	Lower of PV	○			○	AL,FS
15	Upper of Deviation	○			○	DH,FS
16	Lower of Deviation	○			○	DL,FS
17	Upper of Deviation		○		○	DH,RS
18	Lower of Deviation		○		○	DL,RS
19	High/Low deviation out of range	○			○	DO,FS
20	High/Low deviation within of range	○			○	DI,FS
21	Upper of PV		○		○	AH,RS
22	Lower of PV		○		○	AL,RS
23	Upper of Valve **	○			○	VH,FS
24	Lower of Valve **	○			○	VL,FS
25	Upper of TSP	○		○		TSP,H
26	Lower of TSP	○		○		TSP,L
27	SOAK	○		○		SK,F
28	SOAK		○	○		SK,R
28	HBA *	○		○		HBA

* In case of HBA Option

** In case of enter a position proportional feedback

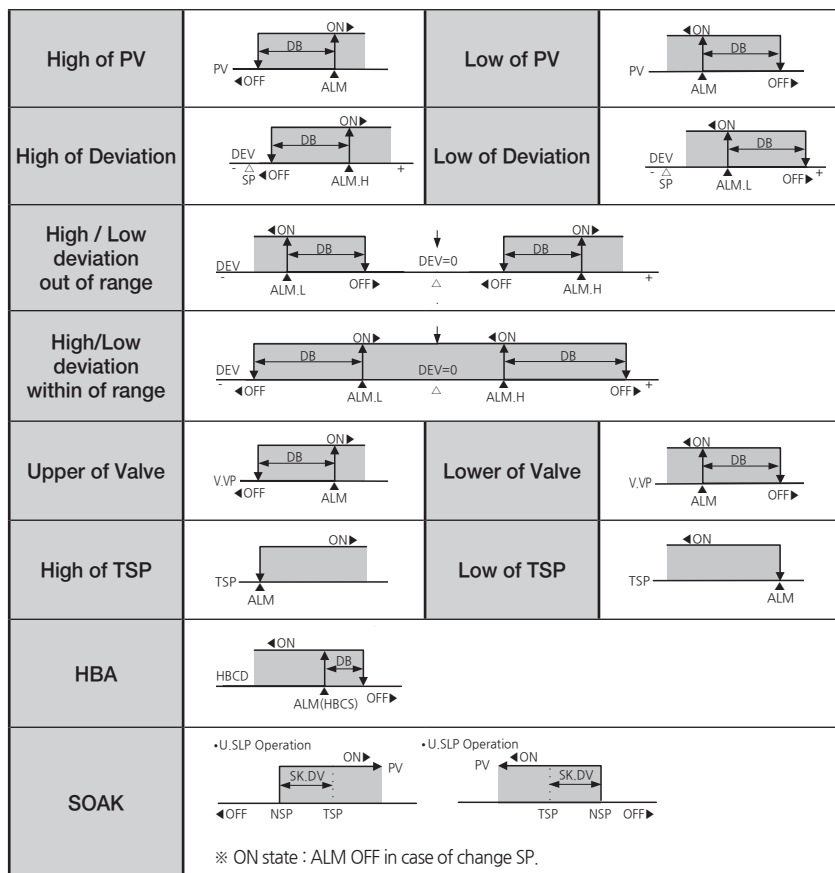

DEV : Deviation, DB : Hysteresis

[Fig.27] Alarm Operation

5.7.7. Soak deviation Setting



■ Parameter for setting Soak Alarm deviation.

Symbol	Parameter	Setting range	Unit	Default	Display
SK.DV	Soak Deviation	EUS(0.0 ~ 10.0%)	EUS	EUS(0.0%)	SK.F, SK.R select



SOAK Alarm ON, OFF Condition

■ UP SLOPE(∧ : SP ramping up)

- ① Check the alarm from the point [$TSP - SK.DV \leq NSP$].
- ② [$NPV > TSP - SK.DV$] "ON".
- ③ [$NPV < TSP - SK.DV$] if "ON" state once, it goes "OFF" when changing SP.

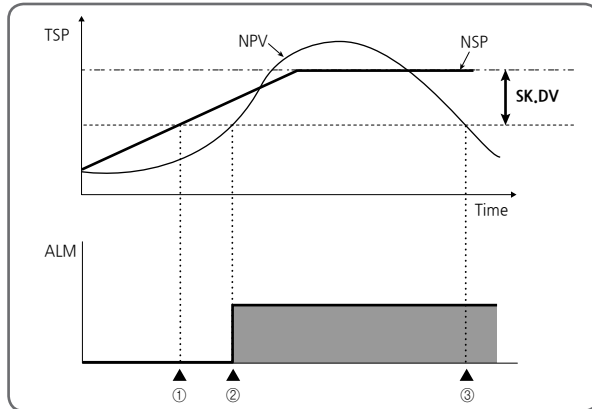

[Fig.28] UP SLOPE(∧ : SP ramping up)

■ DOWN SLOPE(∨ : SP ramping down)

- ① Check the alarm from the point [$TSP + SK.DV \geq NSP$].
- ② [$NPV < TSP + SK.DV$] "ON".
- ③ [$NPV > TSP + SK.DV$] if "ON" once, it goes "OFF" when changing SP.

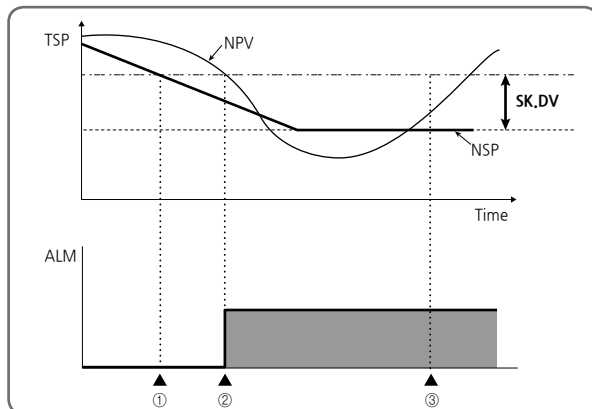

[Fig.29] DOWN SLOPE(∨ : SP ramping down)

5.8. Inner Signal Group(G.IS)

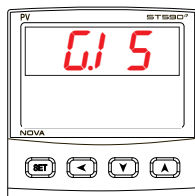

- Group of Inner Signal parameters

5.8.1. Type to be referenced Setting



- Parameter for setting Inner Signal operation.
- When NPV, EUS 0.5% Hysteresis is automatically applied.

Symbol	Parameter	Setting range	Unit	Default	Display
#n.IST	Inner Signal Type	NSP, NPV, TSP	ABS	NPV	Always

#n = 1~2

5.8.2. Out or In band Setting

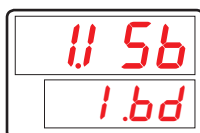

- Parameter for setting direction of Inner Signal band.

Symbol	Parameter	Setting range	Unit	Default	Display
#n.ISB	Inner Signal Band	I.BD, O.BD	ABS	I.BD	Always

#n = 1~2

5.8.3. High/Low limits of band Setting

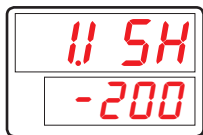

- Parameter for setting high limit value of Inner Signal band.

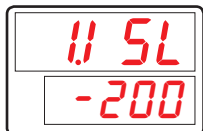

- Parameter for setting low limit value of Inner Signal band.

Symbol	Parameter	Setting range	Unit	Default	Display
#n.ISH	Inner Signal Range High	EU(0.0 ~ 100.0%) (1.ISL ≤ 1.ISH)	EU	EU(0.0%)	Always
#n.ISL	Inner Signal Range Low	EU(0.0 ~ 100.0%) (1.ISL ≤ 1.ISH)	EU	EU(0.0%)	Always

#n = 1~2

5.8.4. Delay Time Setting

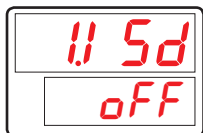

- Parameter for setting output delay time when in condition for Inner Signal operation.

Symbol	Parameter	Setting range	Unit	Default	Display
#n.ISD	Inner Signal Delay	OFF, 0.01 ~ 99.59 (mm:ss)	TIME	OFF	Always

#n = 1~2



Example of Inner Signal Cases

- [Case 1] PV HYS : INPUT = 0.0 ~ 100.0 → EUS 0.5% = 0.5°C

IST	ISB	ISL	ISH	ISD
NPV	IN BAND	30.0°C	50.0°C	00.00

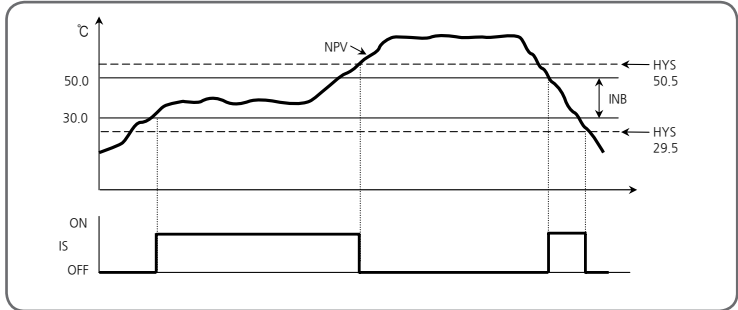

[Fig.30] Example of Inner Signal Case #1

- [Case 2] When U.SLP and D.SLP are OFF

⇒ NSP and TSP operate in identical manner.

IST	ISB	ISL	ISH	ISD
NSP	OUT BAND	30.0°C	50.0°C	00.00

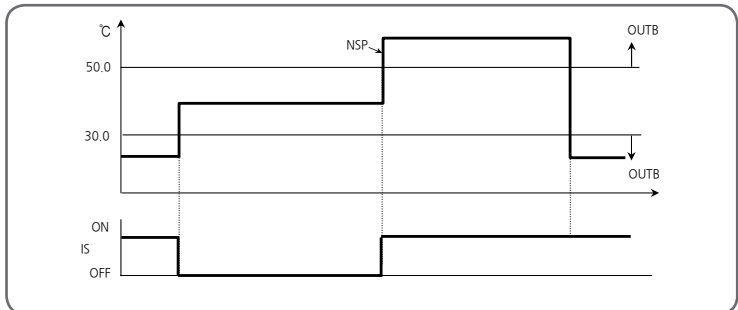

[Fig.31] Example of Inner Signal Case #2



- [Case 3] When U.SLP and D.SLP are not OFF

IST	ISB	ISL	ISH	ISD
NSP	IN BAND	30.0°C	50.0°C	00.10

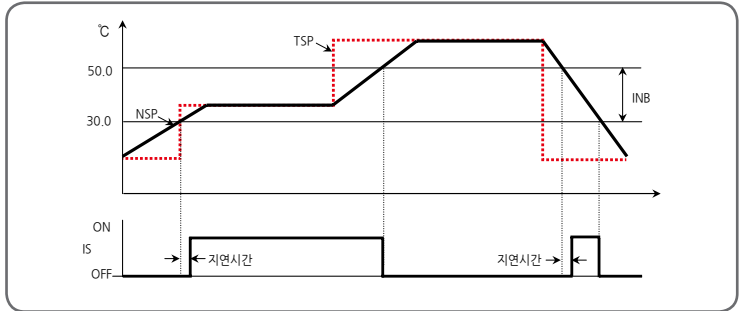

[Fig.32] Example of Inner Signal Case #3

- [Case 4] When U.SLP and D.SLP are not OFF

IST	ISB	ISL	ISH	ISD
TSP	OUT BAND	30.0°C	50.0°C	00.00

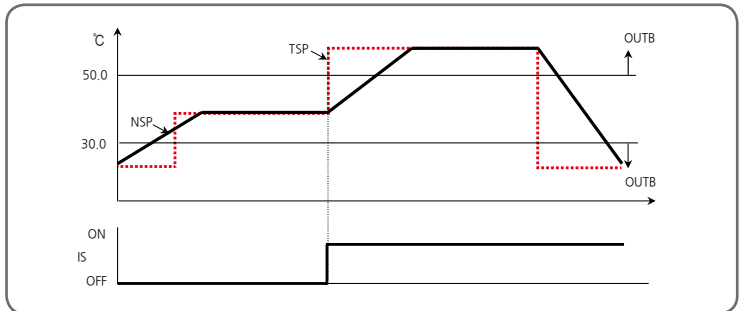

[Fig.33] Example of Inner Signal Case #4

5.9. Timer Group(G.TMR)

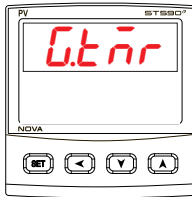

- Group of timer parameters.

5.9.1. Timer operation Setting

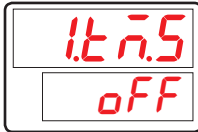

- Parameter for setting start condition of timer.
- When changing the timer type, time unit, and timer time, select one of ①, ② and execute it
 - ① Initialize start condition of timer operation
 - RUN : Execute RUN / STOP
 - DI1,2: Execute DI1,2 ON / OFF
 - ② Reset start condition of timer operation
 - Reset after OFF

Symbol	Parameter	Setting range	Unit	Default	Display
#n.TM.S	Timer Source	OFF, RUN, DI1, DI2 (Note1)	ABS	OFF	Always

#n = 1~2 * (Note1) : DI 1 and 2 are displayed when under setting, DI Option, DISL : 3

5.9.2. Type of Timer Setting

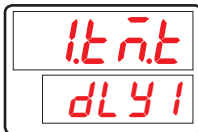

- Parameter for setting timer type.

Symbol	Parameter	Setting range	Unit	Default	Display
#n.TM.T	Timer Source	DLY1, DLY2, FLK1, FLK2, SOAK	ABS	DLY1	Always

#n = 1~2

5.9.3. Timer time unit Setting

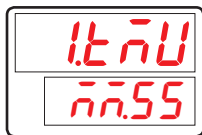

- Parameter for setting timer time unit.

Symbol	Parameter	Setting range	Unit	Default	Display
#n.TMU	Timer Time Unit	HH.MM, MM.SS	ABS	MM.SS	Always

#n = 1~2

5.9.4. Timer time Setting



- Parameter for setting timer delay time.

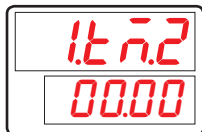

- Parameter for setting timer time.

Symbol	Parameter	Setting range	Unit	Default	Display
#n.TM.1	Timer Time 1	00.00 ~ 99.59 (#n.TMU)	#n.TMU	00.00	Always
#n.TM.2	Timer Time 2	00.00 ~ 99.59 (#n.TMU)	#n.TMU	00.00	Always

#n = 1~2



NOTE

Timer Signal Operation

※ DLY1(DELAY1)

- When TM.S is running, timer is ON after TM.1 (OFF TIME) and OFF when TM.S OFF.
- TMR(Timer Signal)
 - Set in EV1~4 parameters
 - Timer Signal is output in EV1~4, if set TMR1 and TMR2 in EV1~4 settings
- $TM.1 > TM.S \Rightarrow$ Timer is OFF.

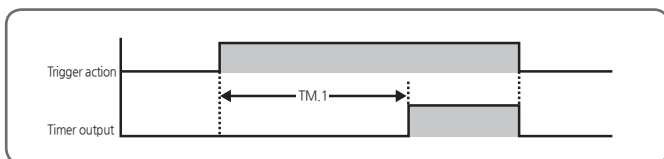

[Fig.34] Timer Delay 1

※ DLY2(DELAY2)

- When TM.S is running, timer is ON after TM.1 (OFF TIME) and OFF after TM.2 (ON TIME).
- $TM.2 > TM.S \Rightarrow$ Timer is OFF.

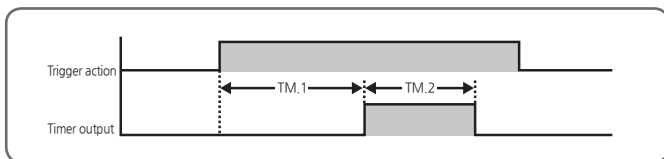

[Fig.35] Timer Delay 2

※ FLK1(FLICKER1)

- When TM.S is running, timer is repeatedly ON after TM.1 (OFF TIME) and OFF after TM.2 (ON TIME).
- $TM.1 = 0 \Rightarrow$ Timer is ON until TM.S OFF.

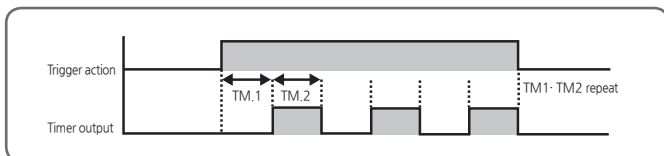

[Fig.36] Timer Flicker 1



※ FLK2(Flicker2)

- When TM.S is running, timer is ON and OFF after TM.2 (ON TIME) and ON again after TM.1 (OFF TIME).
- TM.1 = 0 → Timer is ON until TM.S OFF.

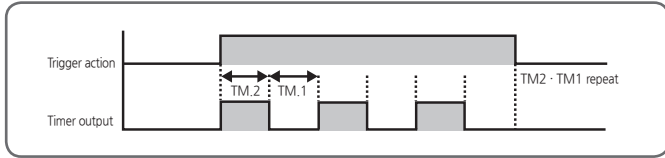

[Fig.37] Timer Flicker 2

※ SOAK

- When RUN, Since the operation is ON TM.S(Timer operation target) from PV = SP point, it will be Off after TM.2 (On Time).

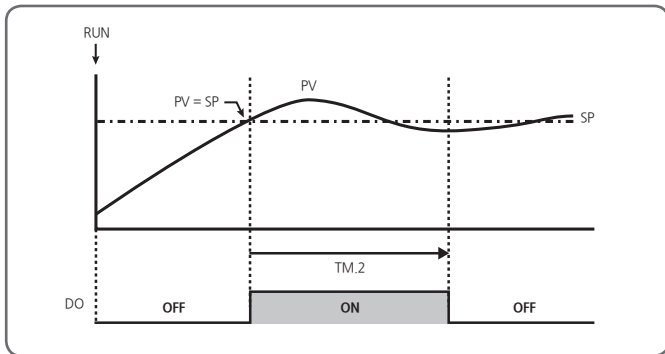

[Fig.38] TM.S : RUN

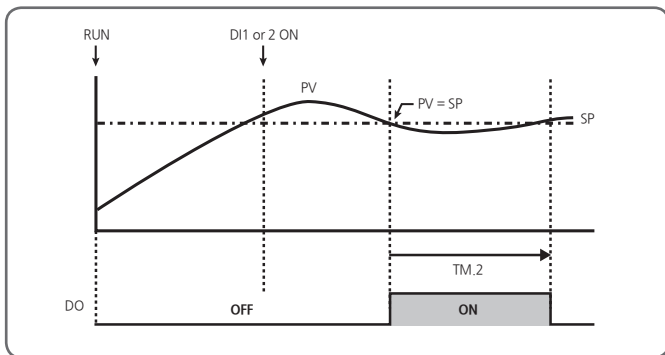

[Fig.39] TM.S : DI1 or 2

5.10. Heater Current Alarm Group(G.HBA)

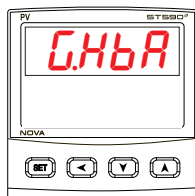

- Group of Heater Current Alarm parameters.

5.10.1. Heater current display Setting



- Parameter for displaying Hater Current.

Symbol	Parameter	Setting range	Unit	Default	Display
HB.CD	Heater Break Current Display	Display only (0~50A)	ABS	-	HBA Option

5.10.2. Heater current alarm point Setting



- Parameter for setting Heater Break values.

Symbol	Parameter	Setting range	Unit	Default	Display
HB.CS	Heater Break alarm Current	OFF, 1 ~ 50A	ABS	OFF	HBA Option

5.10.3. Heater break dead band Setting



- Parameter for setting Heater Break Dead Band.

Symbol	Parameter	Setting range	Unit	Default	Display
HB,DB	Heater Break Alarm Deadband	0 ~ 10A	ABS	1	HBA Option



Conditions for Detecting Heater Break Alarm

- MV output pulse width should be greater than 200ms. If the cycle time is set to 2 sec, MV should be greater than 10% (200ms duty ON).

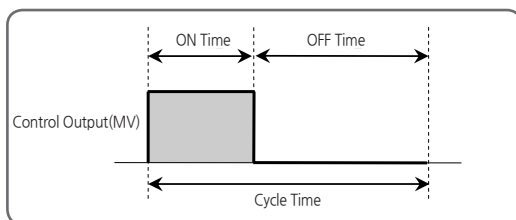

[Fig.40] Conditions for Detecting Heater Break Alarm

5.10.4. Power frequency Setting

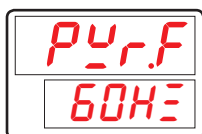

- Parameter for setting heater power frequency when using Heater Break Alarm.

Symbol	Parameter	Setting range	Unit	Default	Display
PWR,F	Power Frequency	60Hz, 50Hz	ABS	60Hz	HBA Option

5.10.5. CT Sensor Step-Up Ratio Setting

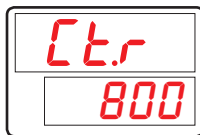

- Parameter for setting Step-Up Ratio of CT Sensor.

- 800 ⇔ 800:1
- 1000 ⇔ 1000:1

Symbol	Parameter	Setting range	Unit	Default	Display
CT.R	Current Trans Ratio	800, 1000	ABS	800	HBA Option

5.10.6. Bar Graph Setting



- Parameter for setting the bar kind of graph.

- MV : Displays the control output yield on a bar graph.
- CUR : Displays the heater amperage on the bar graph.

Symbol	Parameter	Setting range	Unit	Default	Display
B.GRP	Bar Graph	MV, CUR	ABS	MV	HBA Option

5.10.7. Heater Break Graph High/Low Setting

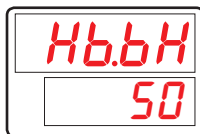

- Parameter for setting the high limit using the type of graph as the bar graph heater current



- Parameter for setting the low limit using the type of graph as the bar graph heater current

Symbol	Parameter	Setting range	Unit	Default	Display
HB.BH	Heater break bar high	0 ~ 50 (HB.BL < HB.BH)	ABS	50	B.GRP=CUR
HB.BL	Heater break bar low		ABS	0	B.GRP=CUR

5.11. Loop Break Alarm Group(G.LBA)

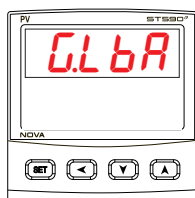

- Group of Loop Break Alarm parameters.

5.11.1. Loop Break Alarm Setting



- Parameter for using Loop Break Alarm.
- Alarm is OFF when stopped or in error.
- Only checks when MV is in OH or OL.

Symbol	Parameter	Setting range	Unit	Default	Display
LBA.U	Loop Break Alarm Use	OFF, ON	ABS	OFF	Always



Alarm is OFF when under AT (Auto Tuning).



Triggering Loop Break Alarm (LBA)

- LBA is turned on when NPV does not change for more than 2.0°C for the duration of LBATM, provided that, MV is on either OH or OL.

Output	Common Control		Heating and Cooling Control	
Forward	OUT = 0.0%(OL)	If NPV does not decrease below 2.0°C for the duration of LBATM	OUT _c = 100.0%(OH _c)	If NPV does not decrease below 2.0°C for the duration of LBATM
	OUT = 100.0%(OH)	If NPV does not increase over 2.0°C for the duration of LBATM	OUT _H = 100.0%(OH _H)	If NPV does not increase over 2.0°C for the duration of LBATM
Reverse	OUT = 0.0%(OL)	If NPV does not increase over 2.0°C for the duration of LBATM	OUT _c = 100.0%(OH _c)	If NPV does not increase over 2.0°C for the duration of LBATM
	OUT = 100.0%(OH)	If NPV does not decrease below 2.0°C for the duration of LBATM	OUT _H = 100.0%(OH _H)	If NPV does not decrease below 2.0°C for the duration of LBATM

5.11.2. Loop Break Alarm Dead Band Setting



- Parameter for setting Loop Break Alarm Dead Band

Symbol	Parameter	Setting range	Unit	Default	Display
LBA.D	Loop break Alarm dead band	EUS(0.0~100.0)	EUS	EUS(0.0)	Always

5.11.3. Loop Break Alarm Time Setting

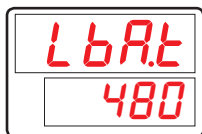

- Parameter for setting Loop Break Alarm Time for checking Loop Break Alarm

Symbol	Parameter	Setting range	Unit	Default	Display
LBA.T	Loop break Alarm time	1 ~ 7200 sec	ABS	480	Always

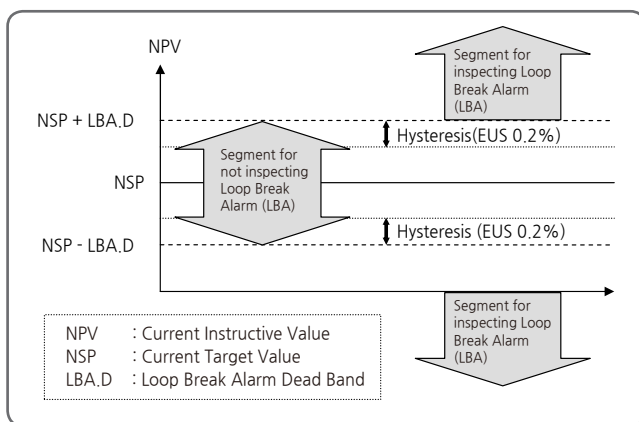

[Fig.41] Loop Break Alarm Dead Band

5.12. Retransmission Group(G.RET)

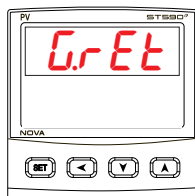

- Group of retransmission parameters

5.12.1. Type of Retransmission Setting



- Parameter for selecting type of retransmission
- LPS : Retransmits supply power for sensors
- PV : Retransmits current sensor input values
- SP : Retransmits current target value
- MV : Retransmits current control output value
- V.VP : Transfer valve position during Position proportional control

Symbol	Parameter	Setting range	Unit	Default	Display
RET	Retransmission Type	LPS, PV, SP, MV, V.VP (V.VP : Position proportiona)	ABS	PV	Always

5.12.2. High/Low Limits of Retransmission Setting

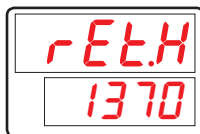

- Parameter for setting high/low limits for retransmission
- If type of retransmission output is PV or SP, high limit (20mA) and low limit (4mA) are set as RET.H and RET.L, respectively.
(If RET is set as MV, RET.H and RET.L are displayed as RET.H = 100.0% and RET.L = 0.0%.)

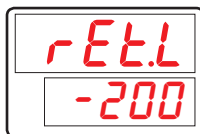

Symbol	Parameter	Setting range	Unit	Default	Display
RET.H	Retransmission High Limit	TC, RTD : IN.RL ~ IN.RH DCV : IN.SL ~ IN.SH (RET.L < RET.H)	EU	IN.RH (TC,RTD) IN.SH (DCV)	RET.T = PV or SP
RET.L	Retransmission Low Limit				



NOTE

Retransmission Output

- In Case the Type of Retransmission is 'PV' or 'SP'

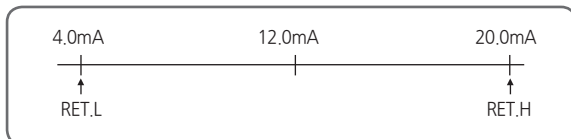

[Fig.42] In Case the Type of Retransmission is 'PV' or 'SP'

- In Case the Type of Retransmission is 'MV'

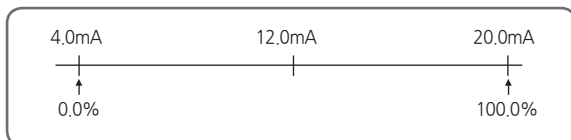

[Fig.43] In Case the Type of Retransmission is 'MV'

5.13. Communication Group(G.COM)

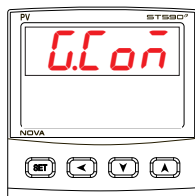

- Group of communication parameters
- For more details, refer to Communication Manual.



- Parameter for setting communication Protocol.

Symbol	Parameter	Setting range	Unit	Default	Display
COM.P	Communication Protocol	PCC0, PCC1, MBS.A, MBS.R, SYN.M, SYN.S, P.OMR, P.MIT, P.LG, P.YKO, P.KEN, P.SIE	ABS	PCC1	Option

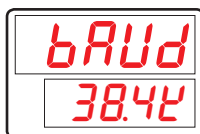

- Parameter for setting communication speed (BAUD RATE).

Symbol	Parameter	Setting range	Unit	Default	Display
BAUD	Baud Rate	9600, 19200, 38.4K, 57.6K, 115.2K	ABS	38.4K	Option



- Parameter for setting Communication Parity.

Symbol	Parameter	Setting range	Unit	Default	Display
PRTY	Parity	NONE, EVEN, ODD	ABS	NONE	Option

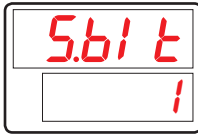

- Parameter for setting Communication Stop Bit.

Symbol	Parameter	Setting range	Unit	Default	Display
S.BIT	Stop Bit	1, 2	ABS	1	Option



- Parameter for setting Communication Data Length.
- Parameter 'D.LEN' is not display when 'COM.P' sets 'MODBUS ASCII' or 'RTU'

Symbol	Parameter	Setting range	Unit	Default	Display
D.LEN	Data Length	7, 8	ABS	8	Option and COM.P = PCC0, PCC1, SYN.M



- Parameter for setting Communication Address for controller.

Symbol	Parameter	Setting range	Unit	Default	Display
ADDR	Address	1 ~ 99 (Max 31 can connect)	ABS	1	Option

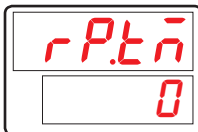

- Parameter for setting Communication Response Time.
- The RP.TM is a Waiting Time to return upper device after processing received commands when controller received it from upper device.
- The setting of RP.TM is setting by 10 msec times. In case of RP.TM = 0, If the processing of commands is over, it returns response to upper device.

Symbol	Parameter	Setting range	Unit	Default	Display
RP.TM	Response Time	0 ~ 10 (x10ms)	ABS	0	Option

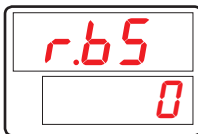

- Parameter for setting compensation value of Remote SP
- In the Case of Master-Slaver, The set point which it comes to give to the Slave is decide with the sum of RBS and Master SP. (If communication protocol is changed, It is initialized)

Symbol	Parameter	Setting range	Unit	Default	Display
R.BS	Remote Bias SP	EUS(-100.0 ~ 100.0%)	EUS	EUS (0.0%)	Option and COM.P = SYN.S

5.14. PLC Group(G.PLC)

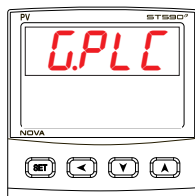

- Group of PLC parameters
- PLC Group is displayed when selected PLC Protocol in Communication Protocol(Range of COM.P : P.OMR, P.MIT, P.LG, P.YKO, P.KEN and P.SIE)
- For more details, refer to Communication Manual.

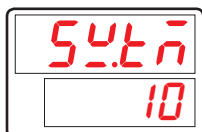

- Parameter for setting Send Delay Time.



- Parameter for setting Receive Delay Time.

Symbol	Parameter	Setting range	Unit	Default	Display
SW.TM	Send Delay Time	0~50	ABS	10	COM.P = PLC
RW.TM	Receive Delay Time	500~1000	ABS	1000	



- Parameter for setting Max Number of Connections.

Symbol	Parameter	Setting range	Unit	Default	Display
MU.NO	Max Number Of Connections	1~31	ABS	1	COM.P = PLC

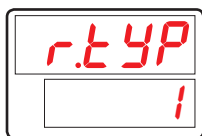

- Parameter for setting Type of Register.

Symbol	Parameter	Setting range	Unit	Default	Display
R.TYP	Register Type	0~3	ABS	0	COM.P = PLC



- Parameter for setting Start Address.

Symbol	Parameter	Setting range	Unit	Default	Display
S.ADR	Start Address	0~FFFF	ABS	03E8	COM.P = PLC



- Parameter for setting Data Map.

Symbol	Parameter	Setting range	Unit	Default	Display
MAP.S	Data Map Select	MAS.M, LOC.M	ABS	MAS.M	COM.P = PLC

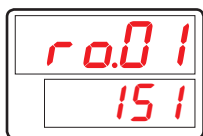

■ Parameter for Setting Read Address.

Symbol	Parameter	Setting range	Unit	Default	Display
RO.01	Read Address 01	OFF, 0~200	ABS	151	COM.P = PLC
⋮	⋮	⋮	⋮	⋮	⋮
RO.13	Read Address 13	OFF, 0~200	ABS	OFF	COM.P = PLC



■ Parameter for setting Write Address.

Symbol	Parameter	Setting range	Unit	Default	Display
RW.01	Write Address 01	OFF, 0~150	ABS	1	COM.P = PLC
⋮	⋮	⋮	⋮	⋮	⋮
RW.15	Write Address 15	OFF, 0~150	ABS	OFF	COM.P = PLC

5.15. Now PLC Display Group(G.NPL)

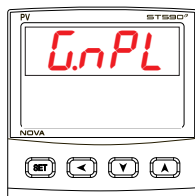

- Group of PLC Display parameters
- PLC Display Group is displayed when selected PLC Protocol in Communication Protocol(Range of COM.P : P.OMR, P.MIT, P.LG, P.YKO, P.KEN and P.SIE)



- Parameter for displaying Now Send Delay Time

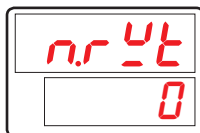

- Parameter for displaying Now Receive Delay Time

Symbol	Parameter	Setting range	Unit	Default	Display
N.SWT	Now Send Delay Time	Reading area	ABS	0	COM.P = PLC
N.RWT	Now Receive Delay Time	Reading area	ABS	0	COM.P = PLC

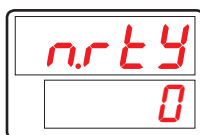

- Parameter for displaying Now Register Type

Symbol	Parameter	Setting range	Unit	Default	Display
N.RTY	Now Register Type	Reading area	ABS	0	COM.P = PLC



- Parameter for displaying Now Start Address

Symbol	Parameter	Setting range	Unit	Default	Display
N.SAD	Now Start Address	Reading area	ABS	0	COM.P = PLC



- Parameter for displaying Now Read Address

Symbol	Parameter	Setting range	Unit	Default	Display
N.O01	Now Read Address 01	Reading area	ABS	OFF	COM.P = PLC
⋮	⋮	⋮	⋮	⋮	⋮
N.O13	Now Read Address 13	Reading area	ABS	OFF	COM.P = PLC



- Parameter for displaying Now Write Address

Symbol	Parameter	Setting range	Unit	Default	Display
N.W01	Now Write Address 01	Reading area	ABS	OFF	COM.P = PLC
⋮	⋮	⋮	⋮	⋮	⋮
N.W15	Now Write Address 15	Reading area	ABS	OFF	COM.P = PLC

6. Display Error and Correction

[Table5] Display Error and Correction

Display Error	Error Contents	Correction
E.SYS	EEPROM, Data Loss	Ask Repair
E.RJC	RJC Sensor Failure	Ask Repair
Flash Decimal Point of SP	Communication Failure	Check Comm Cable
S.OPN	Sensor Open	Check Sensor
E.AT	AT Time Out (27h over)	Check Process
V.OPN	Valve Feedback input burnout	Check the feedback input
V.CER	Automatic valve calibration error	Check Valve Process

Part **II** **Communication
Manual**



Table of Contents

1. Communication Overview	5
1.1. ST500E Communication	5
1.2. Communication Wiring	5
1.3. Communication Parameters	6
2. PC-LINK Communication	8
2.2. CHECK SUM	9
2.3. Type of Commands	10
2.3.1. RSD Command	11
2.3.2. RRD Command	12
2.3.3. WSD Command	13
2.3.4. WRD Command	14
2.3.5. STD Command	15
2.3.6. CLD Command	16
2.3.7. AMI Command	17
2.3.8. Error Code	18
3. MODBUS Communication	19
3.1. Composition of MODBUS Communication Command	19
3.2. Communication Function Code	20
3.2.1. Function Code - 03	21
3.2.2. Function Code - 06	22
3.2.3. Function Code - 08	23
3.2.4. Function Code - 16	24

Table of Contents

4. Programless Communication	25
4.1. Overview.....	25
4.2. Communication Setting	25
4.2.1. Protocol Setting	26
4.2.2. Baud rate, Parity bit, Stop Bit and Data Length Setting	26
4.2.3. Communication Address Setting	27
4.2.4. Send Delay Time, Receive Wait Time	27
4.2.5. Max Number of Connections	27
4.2.6. Register Type Setting	27
4.2.7. Start Address Setting	28
4.2.8. Data Map Setting	29
4.2.9. Memory Area Setting	31
4.3. Data Processing and Communication Status	35
4.3.1. Communication Procedure with PLC	35
4.4. Connection to OMRON PLC	37
4.4.1. Connection Diagram	37
4.4.2. Communication Wiring	37
4.4.3. ST500E Setting	38
4.4.4. PLC Setting	39
4.4.5. Data Monitoring and Setting	40
4.5. Connection to MITSUBISHI PLC	42
4.5.1. Connection Diagram	42
4.5.2. Communication Wiring	42
4.5.3. ST500E Setting	43
4.5.4. PLC Setting	43
4.5.5. Data Monitoring and Setting	44

Table of Contents

4.6. Connection to LG PLC	46
4.6.1. Connection Diagram	46
4.6.2. Communication Wiring	46
4.6.3. ST500E Setting	47
4.6.4. PLC Setting	47
4.6.5. Data Monitoring and Setting	48
4.7. Connection to YOKOGAWA PLC	50
4.7.1. Connection Diagram	50
4.7.2. Communication Wiring	50
4.7.3. ST500E Setting	51
4.7.4. PLC Setting	51
4.7.5. Data Monitoring and Setting	51
4.8. Connection to KEYENCE PLC	53
4.8.1. Connection Diagram	53
4.8.2. Communication Wiring	53
4.8.3. ST500E Setting	54
4.8.4. PLC Setting	54
4.8.5. Data Monitoring and Setting	55
4.9. Connection to SIEMENS PLC	57
4.9.1. Connection Diagram	57
4.9.2. Communication Wiring	57
4.9.3. ST500E Setting	58
4.9.4. PLC Setting	58
4.9.5. Data Monitoring and Setting	59

Table of Contents

5. Other Communication Functions	61
5.1. SYNC Communication	61
5.2. Broadcast Mode	62
5.3. Service Port	63
6. Register Guide	64
6.1. PROCESS	65
6.2. FUNCTION GROUP	66
6.3. SET POINT GROUP	66
6.4. SIGNAL/TIMER GROUP	67
6.5. ALARM GROUP	68
6.6. PID GROUP	69
6.7. IN/OUT GROUP	70
6.8. COMM GROUP	71
6.9. PLC GROUP	71
6.10. NPL GROUP	72
6.11. D-Register Table	73

1. Communication Overview

1.1. ST500E Communication

- ST500E employs the half-duplex RS-485 communication interface which enables connections up to 31 devices.

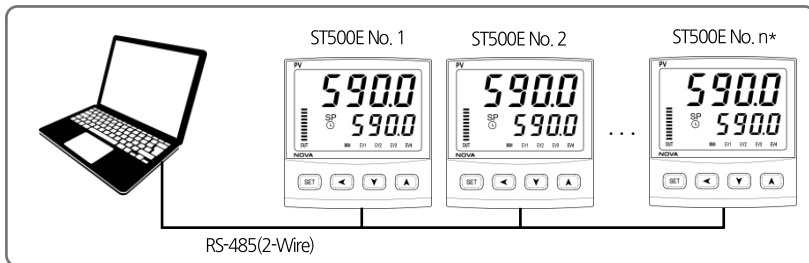

*MAX 31EA

1.2. Communication Wiring

- The RS-485 communication wiring between ST500E and devices are as follows.

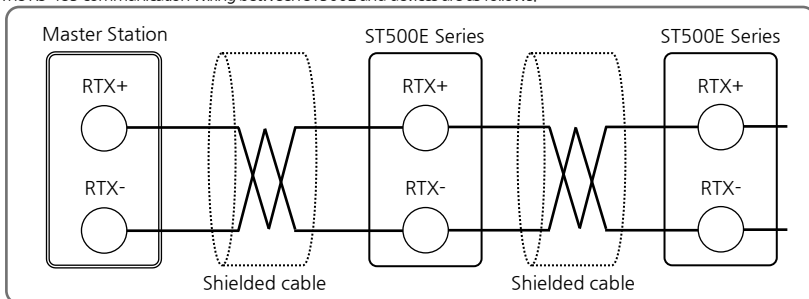

ST590/ST580/ST560	ST570	ST540	ST510
<p>7 RTX+</p> <p>8 RTX-</p>	<p>5 RTX+</p> <p>6 RTX-</p>	<p>17 RTX+</p> <p>18 RTX-</p>	<p>7 RTX+</p> <p>8 RTX-</p>

1.3. Communication Parameters

- Communication parameters are to set the communication conditions and their contents are as follows.

Communication Group Parameters

Parameter	Meaning	Set Value	Description	Initial Value
COM.P	Communication protocol	0	Standard protocol	
		1	Standard protocol + Check Sum	○
		2	MODBUS ASCII	
		3	MODBUS RTU	
		4	SYNC-Master	
		5	SYNC-Slave	
		6	Omron PLC	
		7	Mitsubishi PLC	
		8	LG PLC	
		9	Yokogawa PLC	
		10	Keyence PLC - Modbus slave mode	
11	Siemens PLC			
BAUD	Baud rate	0	9600bps	
		1	19200bps	
		2	38400bps	○
		3	57600bps	
		4	115200bps	
PRTY	Parity bit	NONE	No parity	○
		EVEN	Even parity	
		ODD	Odd parity	
S.BIT	Stop bit	1	1bit	○
		2	2bits	
D.LEN	Data length	7	7bits	
		8	8bits	
ADDR	Address	1~99	Address setting	1
RP.TM	Response time	1 ~ 10	Response time	0
R.BS	Remote SP	-	SP during synchronization	EUS(0.0%)



NOTE

- For the communication settings to apply, turn off and on the device.

PLC Group Parameters

Parameter	Meaning	Set Value	Description	Initial Value
SW.TM	Send delay time	0~50	Send delay [unit :ms]	10
RW.TM	Receive wait time	500~1000	Receive delay [unit :ms]	1000
M.Unit	Max number of units for connection	1~31	Max number of units for connection to programless communication	1
R.TYP	Register type	0~3	Send/receive data area	0
S.ADR	Start address	0~FFFF	Start address setting	3E8
MAP.S	Select data map	0, 1	'0' : Master, '1' : Local	0
RO.01~RO.13	Read area setting	1~200	Reading area address setting[13Ea]	-
RW.01~RW.15	Write area setting	1~150	Writing area address setting[15Ea]	-



NOTE

- PLC Group is displayed when PLC Protocol is selected in Communication Protocol (COM.P).

2. PC-LINK Communication

2.1. Composition of PC-LINK Communication Commands

- Basic communication commands that send data from communication units to ST500E are as follows.

PC-LINK Protocol

①	②	③	④	⑤	⑦	⑧
STX	ST500E address	Command	,	Data by command rule	CR	LF

PC-LINK+SUM Protocol

①	②	③	④	⑤	⑥	⑦	⑧
STX	ST500E address	Command	,	Data by command rule	SUM	CR	LF

① Communication command start text

Indicates start of communication command with STX, an ASCII code, with code value of 0x02

② ST500E address

Indicates unit address, the ST500E unit number for communication.

③ Command

Command for communication(Refer to 2.3. Type of Commands)

④ Separator

Indicates the separators that separate command and data using commas

⑤ Data

Indicates certain strings conforming to communication commands

⑥ SUM

Each of texts between STX and SUM is converted from the 1-byte (8-bit) code to 2-digit (hexadecimal) ASCII codes

⑦, ⑧ End-of-text character

An ASCII code that indicates the end of communication command and expressed as CR(0x0D) or LF(0x0A).

2.2. CHECK SUM

Example of SUM

When reading D-Register from NPV(D0001) to SP.SL(D0005)

Send : [STX]01RSD,05,0001[CR][LF]

Send(incl. CheckSum) : [STX]01RSD,05,0001C8[CR][LF]

- As shown below, each text from 01RSD,05,0001 converted into ASCII code and added as a hexadecimal number is 2C8.

The last two digits, C8, is used as CheckSum.

Text	0	1	R	S	D	,	0	5	,	0	0	0	1
Ascii	30	31	52	53	44	2C	30	35	2C	30	30	30	31



ASCII Control Code Chart

Prefix Suffix	0	1	2	3	4	5	6	7
0	NUL	DLE	SPACE	0	@	P	`	P
1	SOH	DC1	!	1	A	Q	a	q
2	STX	DC2	"	2	B	R	b	r
3	ETX	DC3	#	3	C	S	c	s
4	EOT	DC4	\$	4	D	T	d	t
5	ENQ	NAK	%	5	E	U	e	u
6	ACK	SYN	&	6	F	V	f	v
7	BEL	ETB	'	7	G	W	g	w
8	BS	CAN	(8	H	X	h	x
9	HT	EM)	9	I	Y	i	y
A	LF	SUB	*	:	J	Z	j	z
B	VT	ESC	+	;	K	[k	{
C	FF	FS	,	<	L	¥	l	
D	CR	GS	-	=	M]	m	}
E	SO	RS	.	>	N	^	n	~
F	SI	US	/	?	O	_	o	DEL

2.3. Type of Commands

- Communication commands can be categorized into Self-Information Command to read information of ST500E and Read / Write Command to read or write values in D-Register.

Self-Information Command

Command	Description
AMI	Displays ST500E model name and Version-Revision

Read/Write Command

Command	Description
RSD	Continuous reading of D-Register
RRD	Random reading of D-Register
WSD	Continuous writing of D-Register
WRD	Random writing of D-Register
STD	Random registration of D-Register
CLD	Call D-Register from STD

- Each command may read or write up to 64 D-Registers. In case of STD / CLD, registered items are initialized when power is turned off and register after turned on.

2.3.1. RSD Command

- A command used to read a series of data in D-Register.

Transmission Format

Bytes	1	2	3	1	2	1	4	2	1	1
Description	STX	ST500E address	RSD	,	Number	,	D-Reg.	SUM	CR	LF

Reception Format

Bytes	1	2	3	1	2	1	4	1	...
Description	STX	ST500E address	RSD	,	OK	,	Data - 1	,	...

1	4	2	1	1
,	Data - n	SUM	CR	LF

- Number : 1 ~ 64
- Data : Hexadecimal number without decimal point

Example

- When reading D-Register from NPV(D0001) to NSP(D0002)

Send : [STX]01RSD,02,0001[CR][LF]

Send (incl. CheckSum) : [STX]01RSD,02,0001C6[CR][LF]

([STX] = 0x02, [CR] = 0x0d, [LF] = 0x0a)

- When received NPV(D0001) value is 50.0 and NSP(D0002) value is 30.0

Receive : [STX]01RSD,OK,01F4,012C[CR][LF]

Receive (incl. CheckSum) : [STX] 01RSD,OK,01F4,012C19[CR][LF]

- Process of converting the received PV value of hexadecimal number data to display

① Conversion to decimal number : 01F4(hexadecimal number) → 500(decimal number)

② Multiply 0.1 to converted value : 500 * 0.1 → 50.0

2.3.2. RRD Command

- A command used to read random data in D-Register.

Transmission Format

Bytes	1	2	3	1	2	1	4	1	...
Description	STX	ST500E address	RRD	,	Number	,	D-Reg. - 1	,	...

1	4	2	1	1
,	Data - n	SUM	CR	LF

Reception Format

Bytes	1	2	3	1	2	1	4	1	...
Description	STX	ST500E address	RRD	,	OK	,	Data - 1	,	...

1	4	2	1	1
,	Data - n	SUM	CR	LF

- Number : 1 ~ 64
- Data : Hexadecimal number without decimal point

Example

- When reading D-Register from NPV(D0001) to NSP(D0002)

Send : [STX]01RRD,02,0001,0002[CR][LF]

Send(incl. CheckSum) : [STX]01RRD,02,0001,0002B2[CR][LF]

- When received NPV(D0001) value is 50.0 and NSP(D0002) value is 30.0

Receive : [STX]01RRD,OK,01F4,012C[CR][LF]

Receive(incl. CheckSum) : [STX]01RRD,OK,01F4,012C18[CR][LF]

2.3.3. WSD Command

- A command used to write a series of data in D-Register.

Transmission Format

Bytes	1	2	3	1	2	1	4	1	4
Description	STX	ST500E address	WSD	,	Number	,	D-Reg.	,	Data - 1

1	...	1	4	2	1	1
,	...	,	Data - n	SUM	CR	LF

Reception Format

Bytes	1	2	3	1	2	2	1	1
Description	STX	ST500E address	WSD	,	Number	,	D-Reg.	,

- Number : 1 ~ 64
- Data : Hexadecimal number without decimal point

Example

- When writing data on SP1(D0201) and SP2(D0202) in FIX run Mode

SP1 setting: 50 → To hexadecimal (0x0032)

SP2 setting: 100 → To hexadecimal (0x0064)

Send : [STX]01WSD,02,0201,0032,0064[CR][LF]

Send(incl. CheckSum) : [STX]01WSD,02,0201,0032,0064B3[CR][LF]

2.3.4. WRD Command

- A command used to write random data in D-Register.

Transmission Format

Bytes	1	2	3	1	2	1	4	1	4
Description	STX	ST500E address	WRD	,	Number	,	D-Reg. - 1	,	Data - 1

1	...	1	4	1	4	2	1	1
,	...	,	D-Reg. - n	,	Data - n	SUM	CR	LF

Reception Format

Bytes	1	2	3	1	2	2	1	1
Description	STX	ST500E address	WRD	,	OK	SUM	CR	LF

- Number : 1 ~ 64
- Data : Hexadecimal number without decimal point

Example

- When writing data on SP1(D0201) and SP2(D0204) in FIX run mode

SP1 setting :50.0 °C→ Remove decimal place(500)→ To hexadecimal (0x01F4)

SP4 setting :100.0 °C→ Remove decimal place(1000)→ To hexadecimal (0x03E8)

Send : [STX]01WRD,02,0201,01F4,0204,03E8[CR][LF]

Send(incl. CheckSum) : [STX]01WRD,02,0201,01F4,0204,03E8B5[CR][LF]

2.3.5. STD Command

- A command to pre-register D-Register on ST500E.

Transmission Format

Bytes	1	2	3	1	2	1	4	1	4
Description	STX	ST500E address	STD	,	Number	,	D-Reg. - 1	,	D-Reg. - 2

1	...	1	4	1	4	2	1	1
,	...	,	D-Reg. - n	,	Data - n	SUM	CR	LF

Reception Format

Bytes	1	2	3	1	2	2	1	1
Description	STX	ST500E address	STD	,	OK	SUM	CR	LF

- Number : 1 ~ 64

Example

- When registering NPV(D0001), NSP(D0002) and MVOUT(D0006)

Send : [STX]01STD,03,0001,0002,0006[CR][LF]

Send(incl. CheckSum) : [STX]01STD,03,0001,0002,0006A8[CR][LF]

2.3.6. CLD Command

- A command to read pre-registered D-Register by STD command from ST500E.

Transmission Format

Bytes	1	2	3	2	1	1
Description	STX	ST500E address	CLD	SUM	CR	LF

Reception Format

Bytes	1	2	3	1	2	1	4	1	4
Description	STX	ST500E address	CLD	,	OK	,	Data - 1	,	Data - 2

1	...	1	4	1	4	2	1	1
,	...	,	Data - (n-1)	,	Data - n	SUM	CR	LF

- Data : Hexadecimal number without decimal point

Example

Send : [STX]01CLD[CR][LF]
 Send(incl. CheckSum) : [STX]01CLD34[CR][LF]

2.3.7. AMI Command

- A command used to check information on ST500E.

Transmission Format

bytes	1	2	3	2	1	1
Description	STX	ST500E address	AMI	SUM	CR	LF

Reception Format

bytes	1	2	3	1	2	1
Description	STX	ST500E address	AMI	,	OK	,

9	1	7	2	1	1
모델명	SPACE	Version-Revision	SUM	CR	LF

Example

- When checking information on ST500E

```

Send           : [STX]01AMI[CR][LF]
Send(incl. CheckSum) : [STX]01AMI38[CR][LF]
Receive        : [STX]01AMI,OK,ST59:9696[SP]V00-R00[CR][LF]
Receive(incl. CheckSu) : [STX]01AMI,OK ST59:9696[SP]V00-R0006[CR][LF]

```

2.3.8. Error Code

- The following is sent from ST500E when in error during communication.

Bytes	1	2	2	2	2	1	1
Description	STX	ST500E address	NG	Error code	SUM	CR	LF

Error Codes

Error Code	Description	Note
01	When designated a nonexistent command	
02	WHen designated a nonexistent D-Register	
04	Data setting error	Use of ineffective texts or data (Data employs hexadecimal numbers, 0~9 and A~F)
08	Wrong format	-Format different from designated command -Number different from designated number
11	Checksum error	
12	Monitoring command error	No designated monitoring command
00	Other errors	

3. MODBUS Communication

3.1. Composition of MODBUS Communication Command

- MODBUS communication comes in two modes, ASCII and RTU.

Data Format

Description	ASCII	RTU
Prefix	:(colon)	None
Suffix	[CR][LF]	None
Data Length	7-bit(fixed)	8-bit(fixed)
Data Format	ASCII	Binary
Error Detection	LRC (Longitudinal Redundancy Check)	CRC-16 (Cyclic Redundancy Check)
Data Interval	Less than 1s	Below 24-bit time

- Frame composition is as follows.

Modbus ASCII

Prefix	Communication Address	Function Code	Data	LRC Check	Suffix
1 character	2 characters	2 characters	N characters	2 characters	2 characters (CR+LF)

Modbus RTU

Prefix	Communication Address	Function Code	Data	CRC Check	Suffix
None	8-bit	8-bit	N * 8-bit	16-bit	None

N : Number of hexadecimal data

3.2. Communication Function Code

- MODBUS Communication Function Codes are composed of function codes to read and write D-Register and Loop-Back detection function codes.

Function Code	Description
03	Continuous reading of D-Register
06	Writing of single D-Register
08	Diagnostics(Loop-Back Test)
16	Continuous writing of D-Register



NOTE

When using MODBUS protocol, because D-Register starts from 0, 1 must be subtracted from the numbers in D-Register table.

3.2.1. Function Code - 03

- Function Code – 03 can continuously read up to 64 items in D-Register.

Transmission Format

Description	ASCII	RTU
Communication Prefix	:(Colon)	None
Communication Address	2 characters	8-bit
Function Code - 03	2 characters	8-bit
D-Register Hi	2 characters	8-bit
D-Register Lo	2 characters	8-bit
Number to Read Hi	2 characters	8-bit
Number to Read Lo	2 characters	8-bit
Error Detection	2 characters	16-bit
Communication Suffix	2 characters(CR+LF)	None

Example

- When reading D-Register from NPV(D0001) to NSP(D0002)

MODBUS ASCII : :010300000002FA[CR][LF]

MODBUS RTU : 010300000002C40B



Apply numbers from D-Register table subtracted by 1.

NOTE

Reception Format

Description	ASCII	RTU
Communication Prefix	:(Colon)	None
Communication Address	2 characters	8-bit
Function Code - 03	2 characters	8-bit
Data Bytes	2 characters	8-bit
Data - 1 Hi	2 characters	8-bit
Data - 1 Lo	2 characters	8-bit
...
Data - n Hi	2 characters	8-bit
Data - n Lo	2 characters	8-bit
Error Detection	2 characters	16-bit
Communication Suffix	2 characters(CR+LF)	None

Example

- When the received NPV(D0001) value is 25.0 and NSP(D0002) value is 100.0

MODBUS ASCII : :01030400FA03E813[CR][LF]

MODBUS RTU : 01030400FA03E8DABC

3.2.2. Function Code - 06

- Function Code - 06 allows the sure to enter a single D-Register entry.

Transmission Format

Description	ASCII	RTU
Communication Prefix	:(Colon)	None
Communication Address	2 characters	8-bit
Function Code - 06	2 characters	8-bit
D-Register Hi	2 characters	8-bit
D-Register Lo	2 characters	8-bit
Write Data Hi	2 characters	8-bit
Write Data Lo	2 characters	8-bit
Error Detection	2 characters	16-bit
Communication Suffix	2 characters(CR+LF)	None

Example

- When setting 50 to SP1(D0201) for operation

MODBUS ASCII : :010600C8003294[CR][LF]

MODBUS RTU : 010600C8003289E1



Apply numbers from D-Register table subtracted by 1.

NOTE

Reception Format

Description	ASCII	RTU
Communication Prefix	:(Colon)	None
Communication Address	2 characters	8-bit
Function Code - 06	2 characters	8-bit
D-Register Hi	2 characters	8-bit
D-Register Lo	2 characters	8-bit
Write Data Hi	2 characters	8-bit
Write Data Lo	2 characters	8-bit
Error Detection	2 characters	16-bit
Communication Suffix	2 characters(CR+LF)	None

Example

- Under normal setting, the user will receive as the following.

MODBUS ASCII : :010600C8003294[CR][LF]

MODBUS RTU : 010600C8003289E1

3.2.3. Function Code - 08

- Function Code - 08 is used for self-diagnosis.

Transmission Format

Description	ASCII	RTU
Communication Prefix	:(Colon)	None
Communication Address	2 characters	8-bit
Function Code - 08	2 characters	8-bit
Diagnosis Code Hi	2 characters	8-bit
Diagnosis Code Lo	2 characters	8-bit
Data Hi	2 characters	8-bit
Data Lo	2 characters	8-bit
Error Detection	2 characters	16-bit
Communication Suffix	2 characters(CR+LF)	None

Example

- When sent the following frame for self-diagnosis
 MODBUS ASCII : :010800000002F5[CR][LF]
 MODBUS RTU : 01080000000261CA

Reception Format

Description	ASCII	RTU
Communication Prefix	:(Colon)	None
Communication Address	2 characters	8-bit
Function Code - 08	2 characters	8-bit
Diagnosis Code Hi	2 characters	8-bit
Diagnosis Code Lo	2 characters	8-bit
Data Hi	2 characters	8-bit
Data Lo	2 characters	8-bit
Error Detection	2 characters	16-bit
Communication Suffix	2 characters(CR+LF)	None

Example

- Under normal setting, the user will receive as the following.
 MODBUS ASCII : :010800000002F5[CR][LF]
 MODBUS RTU : 01080000000261CA

3.2.4. Function Code - 16

- Function Code - 16 allows the user to enter up to 64 items in a series of D-Register.

Transmission Format

Description	ASCII	RTU
Communication Prefix	:(Colon)	None
Communication Address	2 characters	8-bit
Function Code - 16	2 characters	8-bit
D-Register Hi	2 characters	8-bit
D-Register Lo	2 characters	8-bit
Number to Write Hi	2 characters	8-bit
Number to Write Lo	2 characters	8-bit
Data Bytes	2 characters	8-bit
Data - 1 Hi	2 characters	8-bit
Data - 1 Lo	2 characters	8-bit
...
Data - n Hi	2 characters	8-bit
Data - n Lo	2 characters	8-bit
Error Detection	2 characters(CR+LF)	None
Communication Suffix	2 characters	16-bit

Example

- When setting 1 and 50 to SPSL(D0200) and SP2(D0201), respectively to change setting

MODBUS ASCII : :011000C70002040001003202[CR][LF]

MODBUS RTU : 011000C700020400010032AFCO

Reception Format

Description	ASCII	RTU
Communication Prefix	:(Colon)	None
Communication Address	2 characters	8-bit
Function Code - 16	2 characters	8-bit
D-Register Hi	2 characters	8-bit
D-Register Lo	2 characters	8-bit
Number to Write Hi	2 characters	8-bit
Number to Write Lo	2 characters	8-bit
Error Detection	2 characters	16-bit
Communication Suffix	2 characters(CR+LF)	None

Example

- Under normal setting, the user will receive as the following.

MODBUS ASCII : :011000C7000227[CR][LF]

MODBUS RTU : 011000C70002A1F5

4. Programless Communication

4.1. Overview

- ST500E can regulate the controller through parameter read/write function without protocol PLC and programs. Also, the Slave Module can receive information from Master Module without additional setting and send them to PLC.

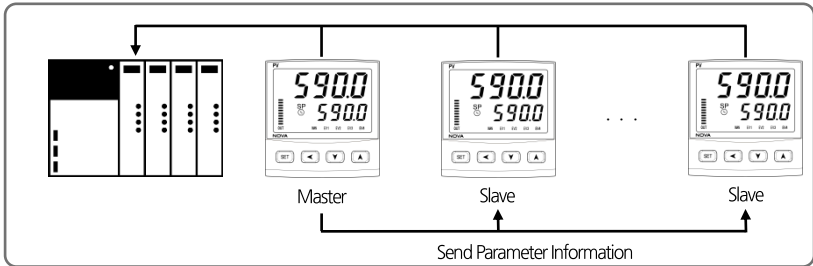

4.2. Communication Setting

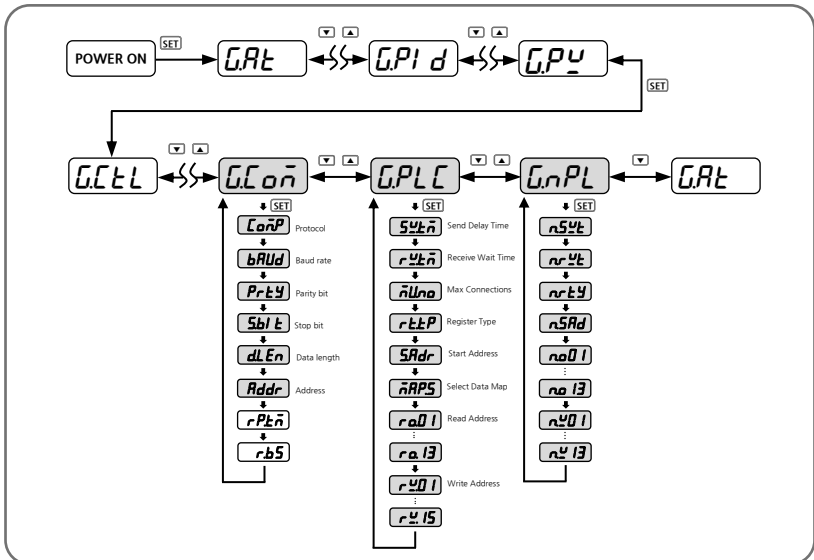

4.2.1. Protocol Setting

- Built-in PLC protocols in ST500E are OMRON, MITSUBISHI, LG, YOKOGAWA, KEYENCE and SIEMENS. The PLC can control and communicate without ladder programs.

Group	Parameter	Set Value	Description
G.Coñ	CoñP	P.oñr	OMRON SYSMAC Protocol
		P.ñl t	MITSUBISHI MELSEC Q/QnACPU Protocol
		P. LG	LG MASTER-K(XGK, XGB, XBC) Protocol
		P.YYo	YOKOGAWA FA-M3 Protocol
		P.YEñ	KEYENCE MODBUS RTU Protocol
		P.SI E	SIEMENS MODBUS RTU Protocol

4.2.2. Baud rate, Parity bit, Stop Bit and Data Length Setting

- For setting speed, parity bit, stop bit and data length for communication.

Group	Parameter	Set Value	Description
G.Coñ	bAUd	9600	9600
		19200	19200
		3840	38400(Initial Value)
		5760	57600
		11520	115200
	Prty	nonE	NONE(Initial Value)
		EYEn	EVEN
		odd	ODD
	Sbit	1, 2	Set communication stop bit (Initial Value : 1)
	dLEn	7, 8	Set communication data length (Initial Value : 8)

4.2.3. Communication Address Setting

- ST500E Series can set up to addresses 1 to 99, where the first, 1, is Master. Master unit is essential for PLC communication.

Group	Parameter	Set Value	Description
<i>GCon</i>	<i>Addr</i>	<i>1~99</i>	Set communication address (Initial Value : 1)

4.2.4. Send Delay Time, Receive Wait Time

- Sets send delay time and receive wait time. Send delay time denotes delay time required for ST500E to send data and receive wait time denotes waiting time for a response from PLC.

Group	Parameter	Set Value	Description
<i>GPLC</i>	<i>SyLn</i>	<i>0~50</i>	Send delay time (Initial Value : 10ms)
	<i>rYLn</i>	<i>500~1000</i>	Receive wait time (Initial Value : 1000ms)

4.2.5. Max Number of Connections

- Max number of connections indicate number of ST590E connected to PLC - the value must be set according to number of modules.

Group	Parameter	Set Value	Description
<i>GPLC</i>	<i>nUno</i>	<i>1~31</i>	Set max connections (Initial Value : 1)

4.2.6. Register Type Setting

- Sets register type. This parameter sets send / receive memory area of PLC.

Group	Parameter	Set Value	Description	
			MITSUBISHI PLC	Other PLC
<i>GPLC</i>	<i>r.tYP</i>	<i>0</i>	D Register	D Register (fixed)
		<i>1</i>	W Register	
		<i>2</i>	R Register	
		<i>3</i>	ZR Register	

4.2.7. Start Address Setting

- Sets start address of PLC memory area. 30 words are uniformly allocated to PLC area according start address setting.

Group	Parameter	Set Value	Description
<i>G.PLC</i>	<i>SAdr</i>	<i>0~FFFF</i>	Start Address Setting (Initial Value :03E8[1000])

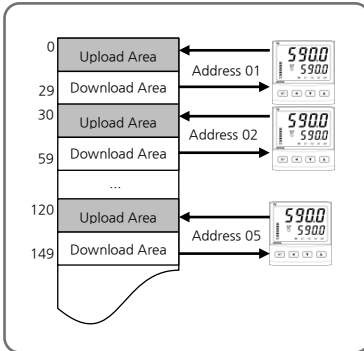

When Start Address of Product is 0

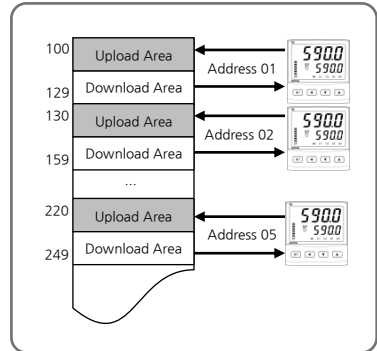

When Start Address of Product is 100[0064]



- ST500E(Slave) Start Address : Start Address (Master) + (ST500E Address - 1) *30

4.2.8. Data Map Setting

- Data Map Setting is composed of 'MASTER' setting that uses information by copying them from a master module and copying into a slave module, and 'LOCAL' setting that uses information in ST500E.

Group	Parameter	Set Value	Description
G.PLC	nAPS	nASn	MASTER Setting (Initial Value)
		LoLn	LOCAL Setting

- If Data Map Setting is MASTER, the slave module receives send delay time, receive wait time, register type, start address and data map information from master module and enter the data into PLC memory area.
- Parameter information from MASTER can be checked in G.NPL Group.

Group	Parameter	Set Value	Description
G.NPL	nSyt	-	Send delay time information
	nrYt	-	Receive wait time information
	nrty	-	Register type information
	nSAd	-	Start address information
	n0.01 ~ n0.13	-	Read area address information [13EA]
	nY.01 ~ nY.15	-	Write area address information[15EA]



- G.NPL Group is a read-only parameter.

Master Setting

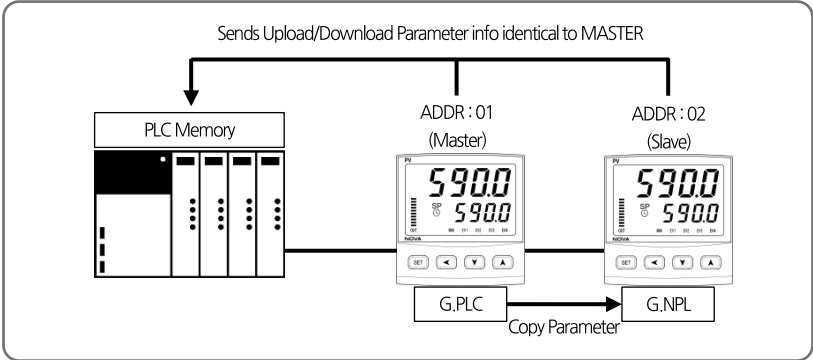

■ Master Setting must be composed of the same product group (SP, ST, SD and SL) for normal operation.

LOCAL Setting

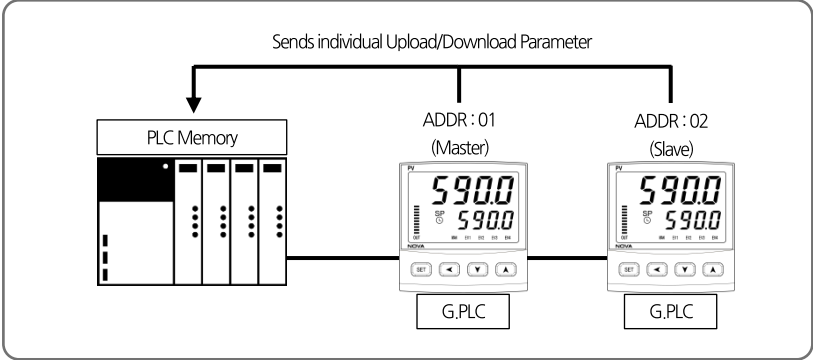

4.2.9. Memory Area Setting

- Sets 13 read-only parameters and 15 read/write parameters to be sent to PLC memory area.
- Users can built a data map by referring to the upload/download setting table and send data map information to PLC memory area.

Group	Parameter	Set Value	Description
G.PLC	<i>ro.01</i> ~ <i>ro.13</i>	<i>1~200</i>	Set read area address [13EA]
	<i>rw.01</i> ~ <i>rw.15</i>	<i>1~150</i>	Set write area address [15EA]

Example

- Setting 161[PROC.TIME] of RO.01 in 151[NPV] will send PROC.TIME value to RO.01 area in PLC.

ST500E Data Map Initial Setting Chart

Parameter	Setting Range	Initial Value	
RO.01	OFF[Not Set], 1 ~ 200	151	NPV
RO.02	OFF[Not Set], 1 ~ 200	152	NSP
RO.03	OFF[Not Set], 1 ~ 200	153	TSP
RO.04	OFF[Not Set], 1 ~ 200	154	MVOUT
RO.05	OFF[Not Set], 1 ~ 200	155	HOUT
RO.06	OFF[Not Set], 1 ~ 200	156	COUT
RO.07	OFF[Not Set], 1 ~ 200	158	NOWSTS
RO.08	OFF[Not Set], 1 ~ 200	159	ALSTS
RO.09	OFF[Not Set], 1 ~ 200	160	DISTS
RO.10	OFF[Not Set], 1 ~ 200	166	HBCD
RO.11	OFF[Not Set], 1 ~ 200	OFF	-
RO.12	OFF[Not Set], 1 ~ 200	OFF	-
RO.13	OFF[Not Set], 1 ~ 200	OFF	-
RW.01	OFF[Not Set], 1 ~ 150	1	R-S[RUN/STOP]
RW.02	OFF[Not Set], 1 ~ 150	6	AT
RW.03	OFF[Not Set], 1 ~ 150	10	SP1
RW.04	OFF[Not Set], 1 ~ 150	14	U.SLP
RW.05	OFF[Not Set], 1 ~ 150	15	D.SLP
RW.06	OFF[Not Set], 1 ~ 150	16	Alarm Value 1
RW.07	OFF[Not Set], 1 ~ 150	17	Alarm High Value 1
RW.08	OFF[Not Set], 1 ~ 150	18	Alarm Low Value 1
RW.09	OFF[Not Set], 1 ~ 150	19	Alarm Value 2
RW.10	OFF[Not Set], 1 ~ 150	20	Alarm High Value 2
RW.11	OFF[Not Set], 1 ~ 150	21	Alarm Low Value 2
RW.12	OFF[Not Set], 1 ~ 150	28	HBCD
RW.13	OFF[Not Set], 1 ~ 150	65	ALBS
RW.14	OFF[Not Set], 1 ~ 150	OFF	-
RW.15	OFF[Not Set], 1 ~ 150	OFF	-

UPLOAD/DOWNLOAD Setting Table

	Set Value	Parameter		
Upload & Download Setting	1	R-S [Run/Stop]	D0101	
	2	A/M	D0105	
	3	H.OUT	D0106	
	4	C.OUT	D0107	
	6	AT	D0121	
	7	S-TM	D0131	
	8	P-TM	D0132	
	9	SPSL	D0200	
	10	SP1	D0201	
	11	SP2	D0202	
	12	SP3	D0203	
	13	SP4	D0204	
	14	U.SLP	D0216	
	15	D.SLP	D0217	
	16	Alarm Value 1	D0406	
	17	Alarm High Value 1	D0421	
	18	Alarm Low Value 1	D0426	
	19	Alarm Value 2	D0407	
	20	Alarm High Value 2	D0422	
	21	Alarm Low Value 2	D0427	
	22	Alarm Value 3	D0408	
	23	Alarm High Value 3	D0423	
	24	Alarm Low Value 3	D0428	
	25	Alarm Value 4	D0409	
	26	Alarm High Value 4	D0424	
	27	Alarm Low Value 4	D0429	
	28	HBCS	D0432	
	29	1.P	D0511	
	30	1.I	D0512	
	31	1.D	D0513	
	32	1.MR	D0514	
	33	1.Pc	D0515	
	34	1.Ic	D0516	
	35	1.Dc	D0517	
	36	1.DB	D0518	
	37	RP1	D0519	
	38	2.P	D0521	
	39	2.I	D0522	
	Upload & Download Setting	40	2.D	D0523
41		2.MR	D0524	
42		2.Pc	D0525	
43		2.Ic	D0526	
44		2.Dc	D0527	
45		2.DB	D0528	
46		RP2	D0529	
47		3.P	D0531	
48		3.I	D0532	
49		3.D	D0533	
50		3.MR	D0534	
51		3.Pc	D0535	
52		3.Ic	D0536	
53		3.Dc	D0537	
54		3.DB	D0538	
55		RHY	D0539	
56		4.P	D0541	
57		4.I	D0542	
58		4.D	D0543	
59		4.MR	D0544	
60		4.Pc	D0545	
61		4.Ic	D0546	
62		4.Dc	D0547	
63		4.DB	D0548	
64		RDV	D0549	
65		ALBS	D0621	
Upload Setting		151	NPV	D0001
		152	NSP	D0002
		153	TSP	D0003
		154	MVOUT	D0006
		155	HOUT	D0007
		156	COUT	D0008
		157	PIDNO	D0009
		158	NOWSTS	D0010
		159	ALSTS	D0014
		160	DISTS	D0015
		161	PROC_TIME	D0020
166		HBCD	D0030	

PLC Register Table

	ST500E Address	Parameter	
BASIC	Start Address + (ST500E ADDRESS - 1) * 30 + 0	Trigger	READ/WRITE
	Start Address + (ST500E ADDRESS - 1) * 30 + 1	Communication Status Flag (STS.F)	READ
R E A D	Start Address + (ST500E ADDRESS - 1) * 30 + 2	RO.01	READ
	Start Address + (ST500E ADDRESS - 1) * 30 + 3	RO.02	READ
	Start Address + (ST500E ADDRESS - 1) * 30 + 4	RO.03	READ
	Start Address + (ST500E ADDRESS - 1) * 30 + 5	RO.04	READ
	Start Address + (ST500E ADDRESS - 1) * 30 + 6	RO.05	READ
	Start Address + (ST500E ADDRESS - 1) * 30 + 7	RO.06	READ
	Start Address + (ST500E ADDRESS - 1) * 30 + 8	RO.07	READ
	Start Address + (ST500E ADDRESS - 1) * 30 + 9	RO.08	READ
	Start Address + (ST500E ADDRESS - 1) * 30 + 10	RO.09	READ
	Start Address + (ST500E ADDRESS - 1) * 30 + 11	RO.10	READ
	Start Address + (ST500E ADDRESS - 1) * 30 + 12	RO.11	READ
	Start Address + (ST500E ADDRESS - 1) * 30 + 13	RO.12	READ
	Start Address + (ST500E ADDRESS - 1) * 30 + 14	RO.13	READ
R E A D & W R I T E	Start Address + (ST500E ADDRESS - 1) * 30 + 15	RW.01	READ/WRITE
	Start Address + (ST500E ADDRESS - 1) * 30 + 16	RW.02	READ/WRITE
	Start Address + (ST500E ADDRESS - 1) * 30 + 17	RW.03	READ/WRITE
	Start Address + (ST500E ADDRESS - 1) * 30 + 18	RW.04	READ/WRITE
	Start Address + (ST500E ADDRESS - 1) * 30 + 19	RW.05	READ/WRITE
	Start Address + (ST500E ADDRESS - 1) * 30 + 20	RW.06	READ/WRITE
	Start Address + (ST500E ADDRESS - 1) * 30 + 21	RW.07	READ/WRITE
	Start Address + (ST500E ADDRESS - 1) * 30 + 22	RW.08	READ/WRITE
	Start Address + (ST500E ADDRESS - 1) * 30 + 23	RW.09	READ/WRITE
	Start Address + (ST500E ADDRESS - 1) * 30 + 24	RW.10	READ/WRITE
	Start Address + (ST500E ADDRESS - 1) * 30 + 25	RW.11	READ/WRITE
	Start Address + (ST500E ADDRESS - 1) * 30 + 26	RW.12	READ/WRITE
	Start Address + (ST500E ADDRESS - 1) * 30 + 27	RW.13	READ/WRITE
	Start Address + (ST500E ADDRESS - 1) * 30 + 28	RW.14	READ/WRITE
	Start Address + (ST500E ADDRESS - 1) * 30 + 29	RW.15	READ/WRITE

4.3. Data Processing and Communication Status

- Able to check communication status with PLC using parameters in BASIC area and read / write data using a trigger.

Parameter	Set Value	Description
Trigger (TRG)	0	Monitor : Reads READ area data
	1	Setting : Writes data on ST500E
	2	Set Value Monitor : Reads READ&WRITE area data
Status Flag (STS,F)	0, 1	Displays communication status

4.3.1. Communication Procedure with PLC

- When the trigger is 0

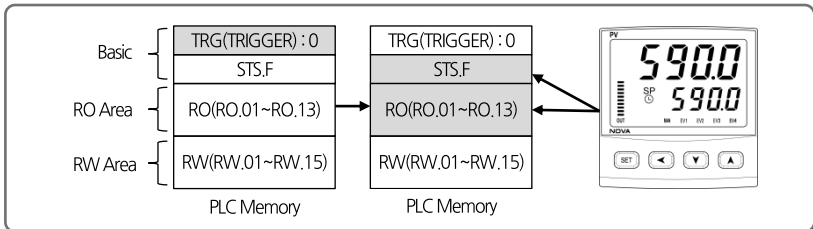

- ① When the trigger is set at 0, it writes READ area (RO.01~RO.13) data in NOVA500E to PLC and reverses communication status flag (0->1, 1->0) and write to PLC.

- When the trigger is 1

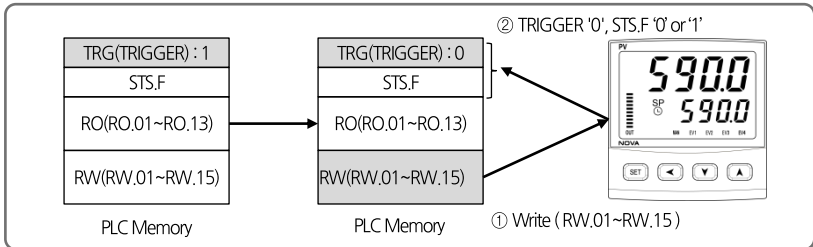

- ① When the trigger is set at 1 in PLC, it writes data in READ&WRITE area (RW.01~RW.15) to ST500E.
- ② Sets triggers from 1 to 0 and reverses communication flag value (0->1, 1->0) and write in PLC.



- It is important to check whether or not the READ & WRITE area is synchronized prior to writing set values as unsynchronized ST500E and PLC set values may influence current ST500E set values.

■ When trigger is 2

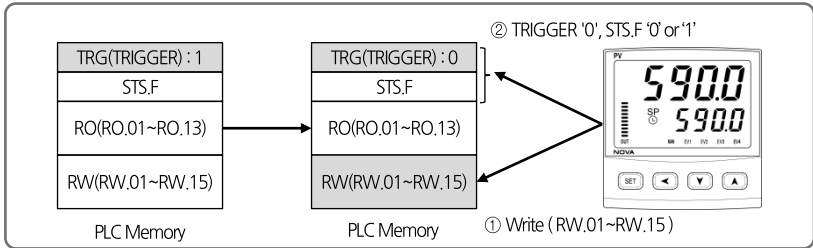

① When the trigger is set at 2 in PLC, it writes data in READ&WRITE area (RW.01~RW.15) to ST500E.

② Sets triggers from 2 to 0 and reverses communication flag value (0->1, 1->0) and write in PLC.



- Because READ&WRITE area is prior to synchronization at first communication with PLC, the user must carry out synchronization after setting trigger to 2 (Set value monitor).

4.4. Connection to OMRON PLC

4.4.1. Connection Diagram

- Next is an example of composition for programless communication with OMRON SYSMAC CJ1M CPU11.

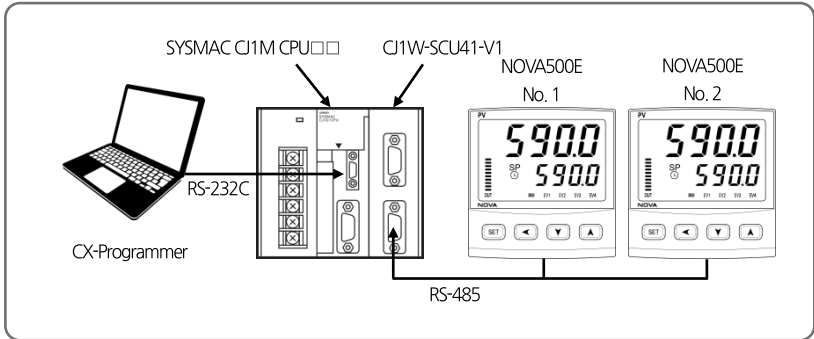

4.4.2. Communication Wiring

- Wire ST500E and CJ1W-SCU41-V1 communication modules as below.

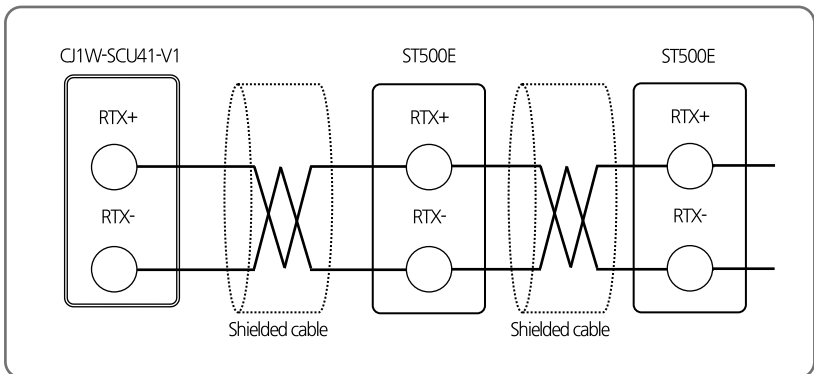

4.4.3. ST500E Setting

- Sets communication parameters pertinent to ST500E Series and PLC for programless communication.
- Refer to 4. Communication Setting and set as below.

1) Sets protocol and communication address in G.COM. Employ default settings for remaining parameters.

Set communication protocol according to PLC type by referring to 4.2.1 Protocol Setting. For communication address setting, set address of MASTER module to 1 and 2 for remaining module addresses.

Communication protocol setting(COM.P) : Set according to PLC type

- ▶ Transmission speed (BAUD) : 38400bps
- ▶ Parity bit(PRTY) : None
- ▶ Stop bit(S.BIT) : 1
- ▶ Data length(D.LEN) : 8
- ▶ Communication address(ADDR) : 1

2) Set max number of connections in G,PLC. Employ default settings for remaining parameters.

Set max number of connections as the last communication address to the current ST500E Series and set data map setting as 'MASTER'.

- ▶ Send delay time(SW.TM) : 10(msec)
- ▶ Receive wait time (RW.TM) : 1000(msec)
- ▶ Max number of connection(MU.NO) : Number of connections by ST500E Series
- ▶ Register type(R.TYP) : 0
- ▶ Start address setting(S.ADR) : 1000
- ▶ Data map setting(MAP.S) : MASTER

4.4.4. PLC Setting

■ Connecting to PLC

- ① Connect PC and OMRON PLC and execute CX-Programmer
- ② From menu, select 'PLC ->Auto Online'
- ③ Upload after a normal connection to PLC

■ Communication setting of module

- ① Select 'PLC -> Operating Mode -> Program' from menu
- ② Double click on 'I/O Table' on the 'Project' window
- ③ Double click on Main Rack on the 'PLC IO Table' window
- ④ Right click on Serial Communications Unit and select Software Switches
- ⑤ Make communication setting from relevant port on Serial CommS Unit Software Switches window. (Refer to ST500E Setting)

Item		Set Value	
Communication Settings	Baud	38400	ST500E Default Value
	Format	1, 8, 1, N	ST500E Default Value
	Mode	Default(Host Link)	ST500E Default Value

- ⑥ Upon completion, select 'Options ->Transfer to PLC' on the Serial CommS Unit Software Switches window to save.

4.4.5. Data Monitoring and Setting

■ ST500E Data Monitoring

- ① Access PLC using CX-Programmer
- ② Double click on 'Memory' on 'Project' window
- ③ Select 'D' on 'PLC Memory' window and click on 'Monitor'
- ④ Check up to 30 words of data per product in relevant register area

- Based upon default value of data map setting, the register area data are as follows.

ADDRESS.1	ADDRESS.2	ADDRESS.3	Parameter	Value
D1000	D1030	D1060	Trigger	0
D1001	D1031	D1061	Communication status flag	1, 0 repeat
D1002	D1032	D1062	NPV	-
D1003	D1033	D1063	NSP	-
D1004	D1034	D1064	TSP	-
D1005	D1035	D1065	MVOUT	-
D1006	D1036	D1066	HOUT	-
D1007	D1037	D1067	COUT	-
D1008	D1038	D1068	NOWSTS	-
D1009	D1039	D1069	ALSTS	-
D1010	D1040	D1070	DISTS	-
D1011	D1041	D1071	HBCD	-
D1015	D1045	D1075	R-S[RUN/STOP]	-
D1016	D1046	D1076	AT	-
D1017	D1047	D1077	SP1	-
D1018	D1048	D1078	U.SLP	-
D1019	D1049	D1079	D.SLP	-
D1020	D1050	D1080	Alarm Value 1	-
D1021	D1051	D1081	Alarm High Value 1	-
D1022	D1052	D1082	Alarm Low Value 1	-
D1023	D1053	D1083	Alarm Value 2	-
D1024	D1054	D1084	Alarm High Value 2	-
D1025	D1055	D1085	Alarm Low Value 2	-
D1026	D1056	D1086	HBCD	-
D1027	D1057	D1087	ALBS	-

RO Area , RW Area

■ **ST500E Set Value Monitoring**

- ① Enter '2 (Read Set Value)' in the register relevant to Trigger Area (D1000)
- ② After the trigger is changed to '2' and data writing is complete in RW area, the trigger is changed to '0' and the process is complete
- ③ Check the values in RW Area(D1015~D1029)

■ **Changing SP through Writing ST500E Set Value**

- ① Enter set value '50' in the register relevant to SP(D1017)
- ③ Enter '1 (Read Set Value)' in the register relevant to Trigger (D1000)
- ⑤ After the trigger is changed to '1' and writing from PLC to ST500E is complete, the trigger is changed to '0' and the process is complete.

4.5. Connection to MITSUBISHI PLC

4.5.1. Connection Diagram

- Next is an example of composition for programless communication with MITSUBISHI Melec Q Series.

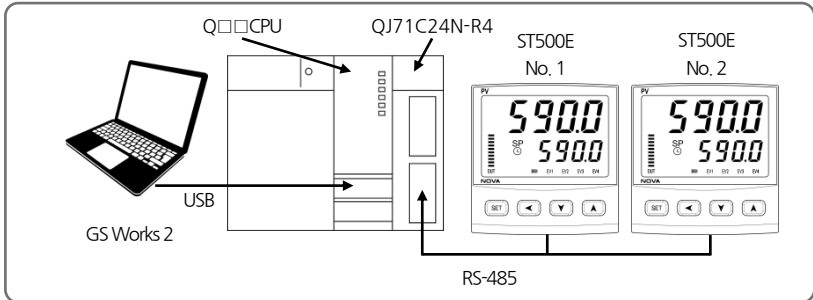

4.5.2. Communication Wiring

- Wire ST500E and QJ71C24N-R4 as below.

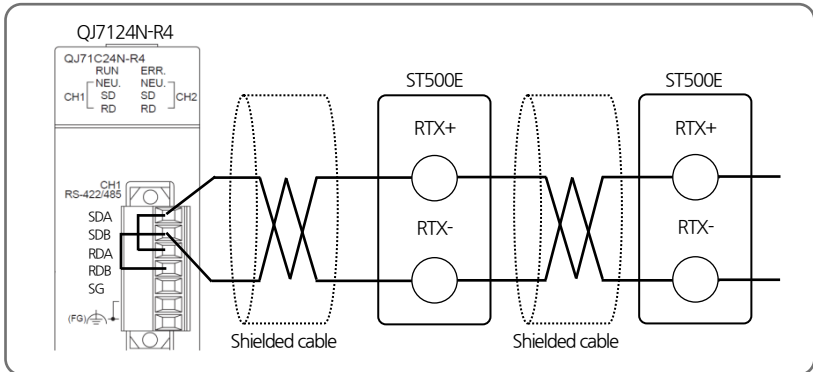

4.5.3. ST500E Setting

- Refer to 4.4.3 ST500E Setting

4.5.4. PLC Setting

■ Connection to PLC

- ① Connect PC and Melsec Q Series CPU and execute GX-Works2
- ② Select 'Online -> Read from PLC' from menu
- ③ Select QCPU(Q mode) and click on 'OK'
- ④ When 'Online Data Operation' window opens, click on 'Execute' to read data
- ⑤ After upload is complete, close the window

■ Communication setting of module

- ① Double click on 'Intelligent Function Module' on 'Navigation' window
- ② Double click on 'QJ71C24N-R4' module and then 'Switch Setting'
- ③ Set communication option parameters of channels connected to ST500E as shown below. (Refer to ST500E SETTING)

Item		Set Value	
Transmission setting	Operation setting	Independent	
	Data Bit	8	ST500E Default Value
	Parity Bit	None	ST500E Default Value
	Even/Odd Parity	None	
	Stop Bit	1	ST500E Default Value
	Sum check code	Exist	-
	Online Change	Enable	-
	Setting modifications	Enable	-
Communication rate setting		38400bps	ST500E Default Value
Communication protocol setting		MC protocol(format 4)	-
Station number setting(0-31)		0	

- ④ After setting is complete, select 'Online -> Write to PLC' from menu
- ⑤ When 'Online Data Operation' window opens, select 'Intelligent Function Module' and check relevant items
- ⑥ Complete setting by clicking on 'Execute'

4.5.5. Data Monitoring and Setting

■ ST500E Data Monitoring

- ① Access PLC using GS Works 2
- ② Select 'Online -> Monitor -> Device Buffer Memory Batch' from menu
- ③ Enter 'D1000' in 'Device Name' on 'Device Buffer Memory Batch' window
- ④ Check up to 30 words of data per product in relevant register area

- Based upon default value of data map setting, the register area data are as follows.

ADDRESS.1	ADDRESS.2	ADDRESS.3	Parameter	Value
D1000	D1030	D1060	Trigger	0
D1001	D1031	D1061	Communication status flag	1, 0 repeat
D1002	D1032	D1062	NPV	-
D1003	D1033	D1063	NSP	-
D1004	D1034	D1064	TSP	-
D1005	D1035	D1065	MVOUT	-
D1006	D1036	D1066	HOUT	-
D1007	D1037	D1067	COUT	-
D1008	D1038	D1068	NOWSTS	-
D1009	D1039	D1069	ALSTS	-
D1010	D1040	D1070	DISTS	-
D1011	D1041	D1071	HBCD	-
D1015	D1045	D1075	R-S[RUN/STOP]	-
D1016	D1046	D1076	AT	-
D1017	D1047	D1077	SP1	-
D1018	D1048	D1078	U.SLP	-
D1019	D1049	D1079	D.SLP	-
D1020	D1050	D1080	Alarm Value 1	-
D1021	D1051	D1081	Alarm High Value 1	-
D1022	D1052	D1082	Alarm Low Value 1	-
D1023	D1053	D1083	Alarm Value 2	-
D1024	D1054	D1084	Alarm High Value 2	-
D1025	D1055	D1085	Alarm Low Value 2	-
D1026	D1056	D1086	HBCD	-
D1027	D1057	D1087	ALBS	-

RO Area , RW Area

■ ST500E Set Value Monitoring

- ① Enter '2 (Read Set Value)' in the register relevant to Trigger Area (D1000)
- ② After the trigger is changed to '2' and data writing is complete in RW area, the trigger is changed to '0' and the process is complete
- ③ Check the values in RW Area(D1015~D1029)

■ Changing SP through Writing ST500E Set Value

- ① Enter set value '50' in the register relevant to SP(D1017)
- ③ Enter '1 (Read Set Value)' in the register relevant to Trigger (D1000)
- ⑤ After the trigger is changed to '1' and writing from PLC to ST500E is complete, the trigger is changed to '0' and the process is complete.

4.6. Connection to LG PLC

4.6.1. Connection Diagram

- Next is an example of composition for programless communication with LS PLC(XBM-DR16S).

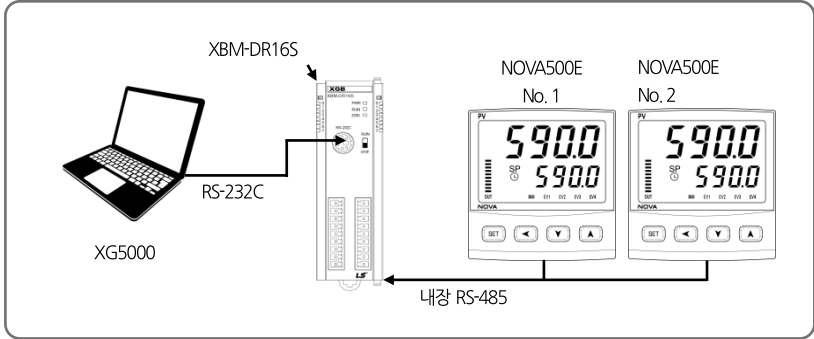

4.6.2. Communication Wiring

- Wire ST500E and XBM-DR16S communication modules as below.

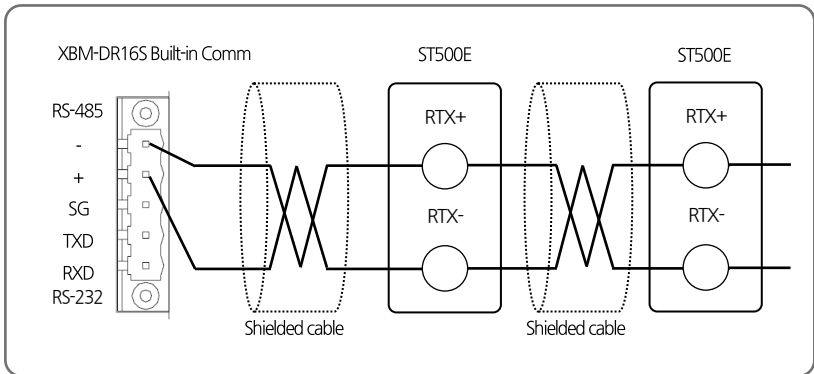

4.6.3. ST500E Setting

- Refer to 4.4.3 ST500E Setting

4.6.4. PLC Setting

- Connection to PLC

- ① Connect PC and LS PLC and execute XG5000
- ② Select 'Project -> Open from PLC' from menu
- ③ Set parameters according to connection method and click on 'Access'

- Communication setting of module

- ① From 'XG5000 Project' window, select 'Network Composition -> Basic Network -> New PLC [BOS0 Built-in Cnet]'
- ② Set relevant channels in Basic Setting window as below

Item		Set Value	
Access Setting	Transmission speed	38400	ST500E Default Value
	Data bit	8	ST500E Default Value
	Stop bit	1	ST500E Default Value
	Parity bit	NONE	ST500E Default Value

- ④ After setting is complete, select 'Online -> Write to PLC' from menu
- ⑤ Complete setting by clicking on 'Confirm' on 'Write' window and changing PLC setting to Writing.

4.6.5. Data Monitoring and Setting

■ ST500E Data Monitoring

- ① Access PLC by using GX5000
- ② Select 'Monitor -> Device Monitor' from menu
- ④ Select 'D' area on 'Device Monitor' window and check relevant register

- Based upon default value of data map setting, the register area data are as follows.

ADDRESS.1	ADDRESS.2	ADDRESS.3	Parameter	Value
D1000	D1030	D1060	Trigger	0
D1001	D1031	D1061	Communication status flag	1, 0 repeat
D1002	D1032	D1062	NPV	-
D1003	D1033	D1063	NSP	-
D1004	D1034	D1064	TSP	-
D1005	D1035	D1065	MVOUT	-
D1006	D1036	D1066	HOUT	-
D1007	D1037	D1067	COUT	-
D1008	D1038	D1068	NOWSTS	-
D1009	D1039	D1069	ALSTS	-
D1010	D1040	D1070	DISTS	-
D1011	D1041	D1071	HBCD	-
D1015	D1045	D1075	R-S[RUN/STOP]	-
D1016	D1046	D1076	AT	-
D1017	D1047	D1077	SP1	-
D1018	D1048	D1078	U.SLP	-
D1019	D1049	D1079	D.SLP	-
D1020	D1050	D1080	Alarm Value 1	-
D1021	D1051	D1081	Alarm High Value 1	-
D1022	D1052	D1082	Alarm Low Value 1	-
D1023	D1053	D1083	Alarm Value 2	-
D1024	D1054	D1084	Alarm High Value 2	-
D1025	D1055	D1085	Alarm Low Value 2	-
D1026	D1056	D1086	HBCD	-
D1027	D1057	D1087	ALBS	-

RO Area , RW Area

■ **ST500E Set Value Monitoring**

- ① Enter '2 (Read Set Value)' in the register relevant to Trigger Area (D1000)
- ② After the trigger is changed to '2' and data writing is complete in RW area, the trigger is changed to '0' and the process is complete
- ③ Check the values in RW Area(D1015~D1029)

■ **Changing SP through Writing ST500E Set Value**

- ① Enter set value '50' in the register relevant to SP(D1017)
- ③ Enter '1 (Read Set Value)' in the register relevant to Trigger (D1000)
- ⑤ After the trigger is changed to '1' and writing from PLC to ST500E is complete, the trigger is changed to '0' and the process is complete.

4.7. Connection to YOKOGAWA PLC

4.7.1. Connection Diagram

- Next is an example of composition for programless communication with YOKOGAWA PLC.

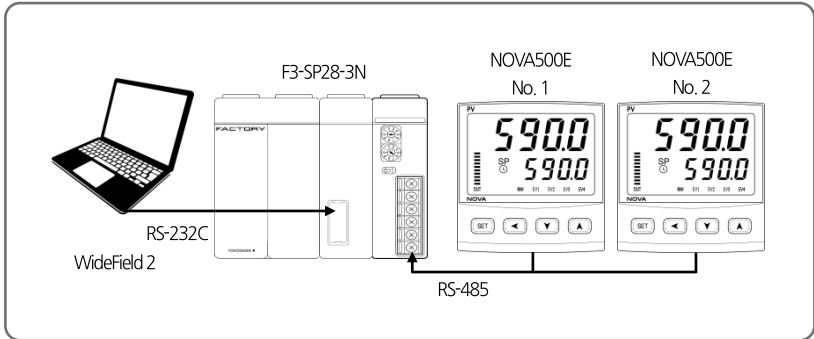

4.7.2. Communication Wiring

- Wire ST500E and LC11-2F as below.

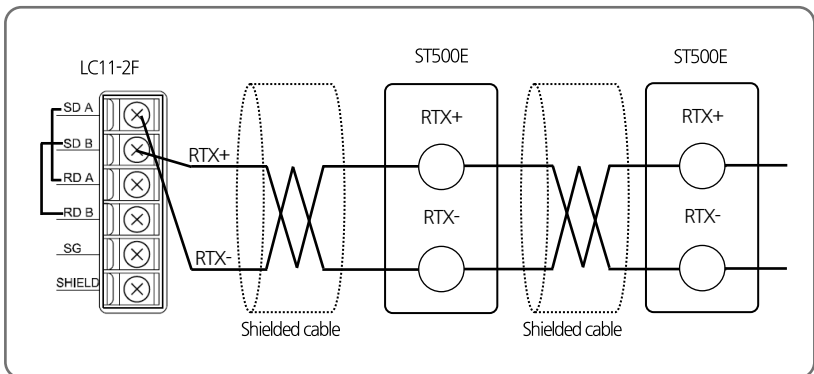

4.7.3. ST500E Setting

- Refer to 4.4.3 ST500E Setting



Data area of YOKOGAWA PLC starts at '1'. Make sure not to set start address of ST500E at '0'.

4.7.4. PLC Setting

- Setting communication module

Open right cover of LC11-2F and set up as below.

Item		Set Value	
SW1		38.4kbps(9)	ST500E Default Value
SW2	Character Length	8bit(ON)	-
	Check Sum	YES(ON)	-
	Terminator	YES(ON)	-

4.7.5. Data Monitoring and Setting

- ST500E Data Monitoring

- ① Access PLC using WideField2
- ② Select 'Online ->Device Monitor-> D Data Register' and check relevant register

- Based upon default value of data map setting, the register area data are as follows.

RO Area

ADDRESS.1	ADDRESS.2	ADDRESS.3	Parameter	Value
D1000	D1030	D1060	Trigger	0
D1001	D1031	D1061	Communication status flag	1, 0 repeat
D1002	D1032	D1062	NPV	-
D1003	D1033	D1063	NSP	-
D1004	D1034	D1064	TSP	-
D1005	D1035	D1065	MVOUT	-
D1006	D1036	D1066	HOUT	-
D1007	D1037	D1067	COU	-
D1008	D1038	D1068	NOWSTS	-
D1009	D1039	D1069	ALSTS	-
D1010	D1040	D1070	DISTS	-
D1011	D1041	D1071	HBCD	-

RW Area

ADDRESS.1	ADDRESS.2	ADDRESS.3	Parameter	값
D1014	D1044	D1074	R-S[RUN/STOP]	-
D1015	D1045	D1075	AT	-
D1016	D1046	D1076	SP1	-
D1017	D1047	D1077	U.SLP	-
D1018	D1048	D1078	D.SLP	-
D1019	D1049	D1079	Alarm Value 1	-
D1020	D1050	D1080	Alarm High Value 1	-
D1021	D1051	D1081	Alarm Low Value 1	-
D1022	D1052	D1082	Alarm Value 2	-
D1023	D1053	D1083	Alarm High Value 2	-
D1024	D1054	D1084	Alarm Low Value 2	-
D1025	D1055	D1085	HBCD	-
D1026	D1056	D1086	ALBS	-

■ ST500E Set Value Monitoring

- ① Enter '2 (Read Set Value)' in the register relevant to Trigger Area (D1000)
- ② After the trigger is changed to '2' and data writing is complete in RW area, the trigger is changed to '0' and the process is complete
- ③ Check the values in RW Area(D1015~D1029)

■ Changing SP through Writing ST500E Set Value

- ① Enter set value '50' in the register relevant to SP(D1017)
- ③ Enter '1 (Read Set Value)' in the register relevant to Trigger (D1000)
- ⑤ After the trigger is changed to '1' and writing from PLC to ST500E is complete, the trigger is changed to '0' and the process is complete.

4.8. Connection to KEYENCE PLC

4.8.1. Connection Diagram

- Next is an example of composition for programless communication with KEYENCE PLC.

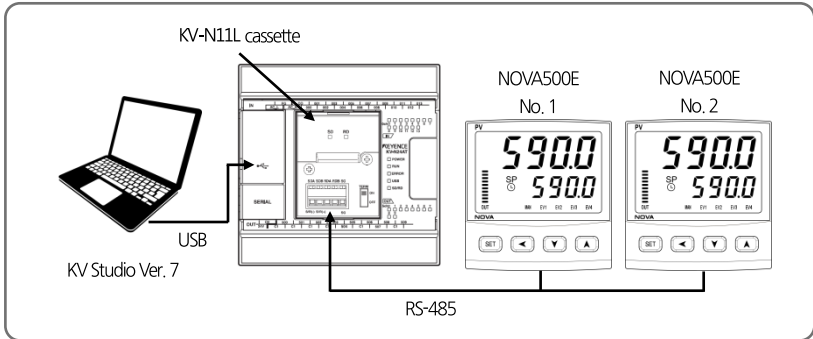

4.8.2. Communication Wiring

- Wire ST500E and KV-N11L Cassette as below.

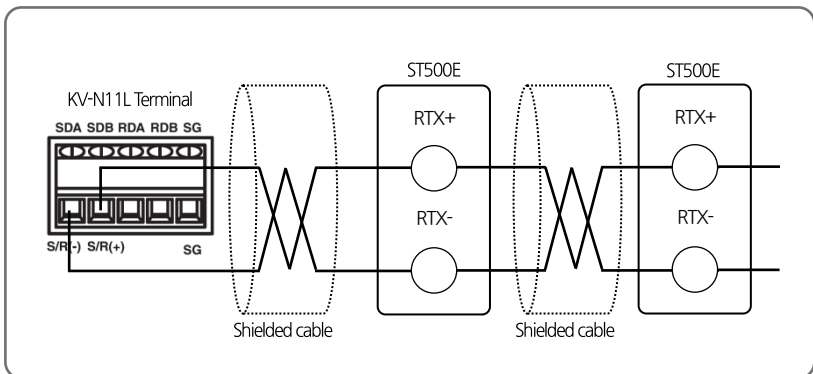

4.8.3. ST500E Setting

- Refer to 4.4.3 ST500E Setting

4.8.4. PLC Setting

■ Communication module setting

- ① Connect PC and KV-N14DT and execute KV Studio
- ② Select 'Monitor/Simulator -> Setup communication -> Setup Communication' from menu
- ③ Select USB as communication method and click on 'OK'
- ③ Select 'Monitor/Simulator -> Read from PLC' from menu and click on 'Execute' on Read PLC window
- ④ After reading PLC, double click on 'Unit configuration -> KV-N14' on Workspace window
- ⑤ Set 'Extension cassette(port 1)' items in Unit Editor window as below. Click on 'Apply' and close window.

Item	Set Value	
Operation Mode	Modbus slave mode	-
Interface	RS-485(2 Wire - type)	-
Baud rate	38400	ST500E Default Value
Stop bit	1	ST500E Default Value
Parity	NONE	ST500E Default Value
Modbus slave station No. setting method	Unit editor	-
Modbus slave station No.	1	-

- ⑥ Select 'Monitor/Simulator -> Transfer to PLC' from menu and select 'Execute' Transfer PLC window.

4.8.5. Data Monitoring and Setting

■ ST500E Data Monitoring

- ① Access PLC using KV Studio
- ② Select 'Monitor/Simulator -> Monitor Mode' from menu
- ④ Select 'Monitor/Simulator -> Batch monitor window' from menu and check data in Batch monitor window.

- Based upon default value of data map setting, the register area data are as follows.

ADDRESS.1	ADDRESS.2	ADDRESS.3	Parameter	Value
DM1000	DM1030	DM1060	Trigger	0
DM1001	DM1031	DM1061	Communication status flag	1, 0 repeat
DM1002	DM1032	DM1062	NPV	-
DM1003	DM1033	DM1063	NSP	-
DM1004	DM1034	DM1064	TSP	-
DM1005	DM1035	DM1065	MVOUT	-
DM1006	DM1036	DM1066	HOUT	-
DM1007	DM1037	DM1067	COU	-
DM1008	DM1038	DM1068	NOWSTS	-
DM1009	DM1039	DM1069	ALSTS	-
DM1010	DM1040	DM1070	DISTS	-
DM1011	DM1041	DM1071	HBCD	-
DM1015	DM1045	DM1075	R-S[RUN/STOP]	-
DM1016	DM1046	DM1076	AT	-
DM1017	DM1047	DM1077	SP1	-
DM1018	DM1048	DM1078	U.SLP	-
DM1019	DM1049	DM1079	D.SLP	-
DM1020	DM1050	DM1080	Alarm Value 1	-
DM1021	DM1051	DM1081	Alarm High Value 1	-
DM1022	DM1052	DM1082	Alarm Low Value 1	-
DM1023	DM1053	DM1083	Alarm Value 2	-
DM1024	DM1054	DM1084	Alarm High Value 2	-
DM1025	DM1055	DM1085	Alarm Low Value 2	-
DM1026	DM1056	DM1086	HBCD	-
DM1027	DM1057	DM1087	ALBS	-

RO Area , RW Area

■ **ST500E Set Value Monitoring**

- ① Enter '2 (Read Set Value)' in the register relevant to Trigger Area (DM1000)
- ② After the trigger is changed to '2' and data writing is complete in RW area, the trigger is changed to '0' and the process is complete
- ③ Check the values in uploaded RW Area(D1015~D1029)

■ **Changing SP through Writing ST500E Set Value**

- ① Enter set value '50' in the register relevant to SP(D1017)
- ③ Enter '1 (Read Set Value)' in the register relevant to Trigger (D1000)
- ⑤ After the trigger is changed to '1' and writing from PLC to ST500E is complete, the trigger is changed to '0' and the process is complete.

4.9. Connection to SIEMENS PLC

4.9.1. Connection Diagram

- Next is an example of composition for programless communication with SIEMENS PLC.

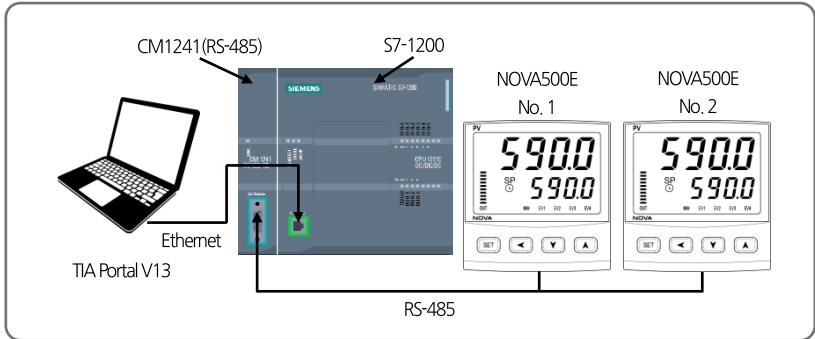

4.9.2. Communication Wiring

- Wire ST500E and CM1241 as below.

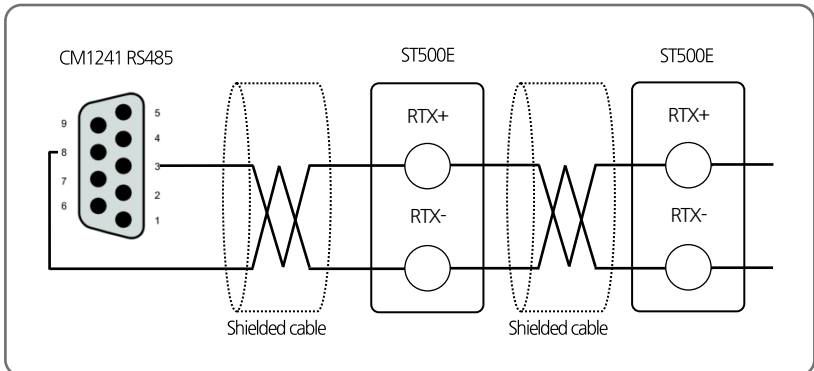

4.9.3. ST500E Setting

- Refer to 4.4.3 ST500E Setting

4.9.4. PLC Setting

■ CM1241 (RS-485) Module Setting

- ① Create Slave PLC Project
- ② Set Port Configuration of CM1241 (RS-485) from Device Configuration in Slave PLC.

Item	Set Value
Transmission rate	9.6kbps
Parity	Even parity
Data bits	8bit per character
Stop bits	1
Wait time	1

- ③ Check Hardware Identifier of CM1241.

■ Slave PLC Sample Logic Programming

- ① Create Global DB from sending and receiving data and enter parameters as below.

Item	Set Value
Name	MB_HOLD_REG
Data type	Struct
Offset	0.0
Retain	Checked
Accessible from HMI	Checked
Visible in HMI	Checked
Set point	Unchecked

- ② Call MB_COMM_LOAD from OB1 and enter parameters as below.

Item	Set Value
REQ	first scan(Address : %M1.0)
PORT	296(Check CM1241 Hardware Identifier)
BAUD	38400
PARITY	0
MB_DB	MB_SLAVE_DB
DONE	Tag_1(Address : %M200.0)
ERROR	Tag_2(Address : %M200.1)
STATUS	Tag_3(Address : %MW202)

③ Call MB_SLAVE from OB1 and enter parameters as below.

Item	Set Value
MB_ADDR	1
MB_HOLD_REG	P#DB3.DBX0.0WORD2000
NDR	-
DR	0
ERROR	MB_SLAVE_DB
STATUS	Tag_4(Address : %MW203)

4.9.5. Data Monitoring and Setting

■ ST500E Data Monitoring

- ① Connect to PLC using TIA Portal V13.
- ② 30 words are allocated in line with the order of ST500E connected to MB_HOLD_REG in MB_SLAVE_DB.

■ Based upon default value of data map setting, the register area data are as follows.

ADDRESS.1	ADDRESS.2	ADDRESS.3	Parameter	Value
DB1000	DB1030	DB1060	Trigger	0
DB1001	DB1031	DB1061	Communication status flag	1, 0 repeat
DB1002	DB1032	DB1062	NPV	-
DB1003	DB1033	DB1063	NSP	-
DB1004	DB1034	DB1064	TSP	-
DB1005	DB1035	DB1065	MVOUT	-
DB1006	DB1036	DB1066	HOUT	-
DB1007	DB1037	DB1067	COU	-
DB1008	DB1038	DB1068	NOWSTS	-
DB1009	DB1039	DB1069	ALSTS	-
DB1010	DB1040	DB1070	DISTS	-
DB1011	DB1041	DB1071	HBCD	-
DB1014	DB1044	DB1074	R-S[RUN/STOP]	-
DB1015	DB1045	DB1075	AT	-
DB1016	DB1046	DB1076	SP1	-
DB1017	DB1047	DB1077	U.SLP	-
DB1018	DB1048	DB1078	D.SLP	-
DB1019	DB1049	DB1079	Alarm Value 1	-
DB1020	DB1050	DB1080	Alarm High Value 1	-
DB1021	DB1051	DB1081	Alarm Low Value 1	-
DB1022	DB1052	DB1082	Alarm Value 2	-
DB1023	DB1053	DB1083	Alarm High Value 2	-
DB1024	DB1054	DB1084	Alarm Low Value 2	-
DB1025	DB1055	DB1085	HBCD	-
DB1026	DB1056	DB1086	ALBS	-

RO Area , RW Area

■ ST500E Set Value Monitoring

- ① Enter '2 (Read Set Value)' in the register relevant to Trigger Area (DB1000)
- ② After the trigger is changed to '2' and data writing is complete in RW area, the trigger is changed to '0' and the process is complete
- ③ Check the values in the uploaded RW Area(D1015~D1029)

■ Changing SP through Writing ST500E Set Value

- ① Enter set value '50' in the register relevant to SP(D1017)
- ③ Enter '1 (Read Set Value)' in the register relevant to Trigger (D1000)
- ⑤ After the trigger is changed to '1' and writing from PLC to ST500E is complete, the trigger is changed to '0' and the process is complete.

5. Other Communication Functions

5.1. SYNC Communication

- SYNC Communication sends operation information (Run/Stop, SP) of master control unit to up to 31 slave units and sync operating conditions.

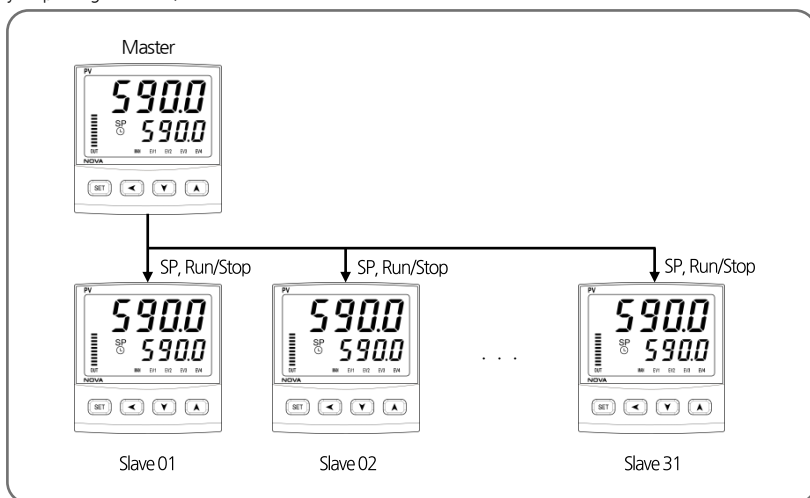

5.1.1 SYNC-Master

- **Master Setting**
 - Change COM.P to SYNC-Master (SYN.M) to set as SYNC-Master.
- **Models that can be set as Master**
 - They are SP590E, SP580E, SP570E, SP540E, ST590E, ST580E, ST570E and ST540E.

5.1.2 SYNC-Slave

- **Slave Setting**
 - Change COM.P to SYNC-Slave(SYN.S) to set as SYNC-Slave..
 - Change SP type (SPSL) to Remote Set Point(RSP).
- **Models that can be set as Slave**
 - They are ST590E, ST580E, ST570E and ST540E.

5.2. Broadcast Mode

- Broadcast Mode sends the same command to all ST500Es connected to higher communication unit to carry out the same task.

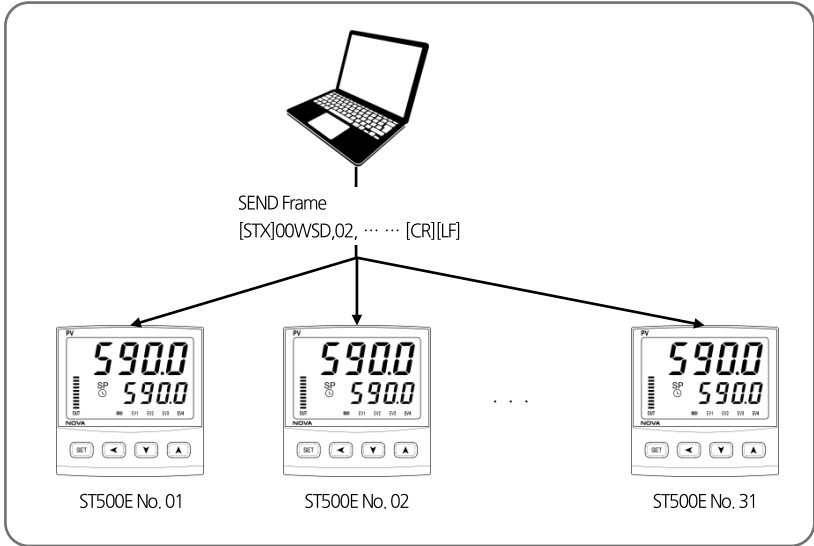

- **Broadcast Mode Communication Method**

- To communicate with Broadcast Mode, set Frame Address to '00' and send



NOTE

Only applies to Write-related commands.

- **Broadcast Mode Usable Protocols**

- Only applicable to the following protocols : PC-LINK, PC-LINK+SUM, MODBUS-RTU and MODBUS-ASCII

5.3. Service Port

- Service port is a communication port for setting parameters and updating firmwares.
- You can check Micro-USB port by removing the 'Service Port' sticker as shown below.

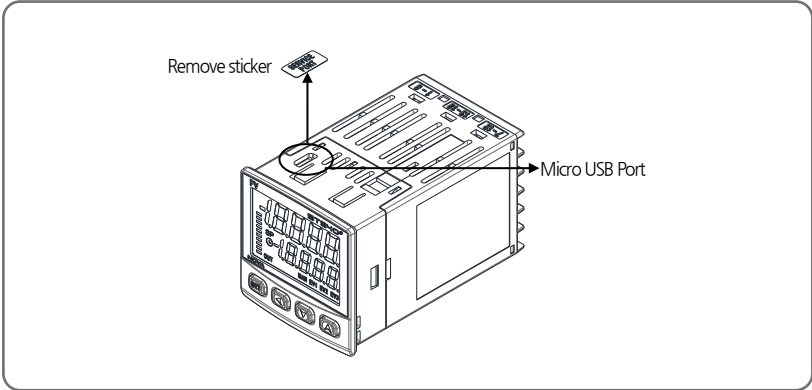

■ Service Port Specifications

Parameter	Set Value
Protocol	PCC1(PC-LINK+SUM)
Transmission speed	38400bps
Stop bit	1
Parity bit	NONE
Data length	8
Communication address	1

- The Service Port requires a Micro-USB cable and a converter that are sold separately.

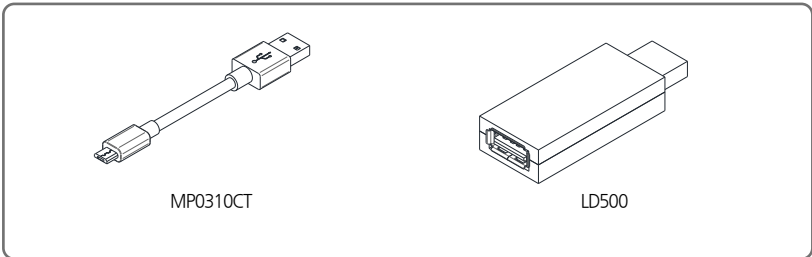

6. Register Guide

- D-Register is a group of data that can check the all status of ST500E through communication.
- They are in groups of 100 according to their contents as the following.

D-Register Range	Group Name	Description	Read	Write
D0001~D0099	PROCESS	Basic operation info display D-Register group	○	◆
D0100~D0199	FUNCTION	Operation setting D-Register group	○	○
D0200~D0299	SET POINT	SP setting D-Register group	○	○
D0300~D0399	SIGNAL/TIMER	Signal/timer setting D-Register group	○	○
D0400~D0499	ALARM	Alarm setting D-Register group	○	○
D0500~D0599	PID	PID setting D-Register group	○	○
D0600~D0699	IN/OUT	Input/control & trans output setting D-Register group	○	△
D0700~D0799	PLC/NPL	PLC setting D-Register group	○	△

- : Able to read or write in all parameters within applicable range.
- △ : Able to partially read or write within applicable range.
- ◆ : Unable to write in all parameters within applicable range.

6.1. PROCESS

- PROCESS Group stores basic data generated during operation. Of the data includes Bit Map which displays various states in bit as the following.
- Status Information D-Register

D-Reg.	Symbol	Description
D0001	NPV	Current measured value
D0002	NSP	Current set value
D0003	TSP	Target value
D0005	SP.SL	SP number under operation
D0006	MVOUT	Control output quantity
D0007	H.OUT	Heater output quantity
D0008	C.OUT	Cooler output quantity
D0009	PID.NO	Currently applied PID number
D0010	NOW.STS	Operation status information
D0014	ALM.STS	Alarm information
D0015	DI.STS	DI information
D0017	SIG.STS	Signal information
D0019	ERROR	Error information
D0020	PROC.TIME	Operating time information
D0021	VVP	[Position proportional control] Current valve position
D0030	HB.CD	Heater current value

- Status Information Register Bit Map Information

BIT	NOW STATUS	ALARM STATUS	DI STATUS	SIGNAL STATUS	ERROR STATUS
	D0010	D0014	D0015	D0017	D0019
0	RUN/STOP	ALM1	DI1	IS1	
1		ALM2	DI2	IS2	
2		ALM3			
3		ALM4			
4		EVENT1			
5		EVENT2			
6		EVENT3(Optional)			
7		EVENT4(Optional)			
8		HBA			+OVER
9		LBA			-OVER
10		TIMER1			S.OPN
11		TIMER2			
12	AT				
13	AUTO/MAN				
14					
15					

6.2. FUNCTION GROUP

- FUNCTION Group is composed of D-Registers pertinent to operation and function setting.

D-Reg.	Symbol	Description
D0101	RUN/STOP	Set operation status(0: RUN, 1: STOP)
D0105	AUTO/MAN	Set AUTO/MAN
D0106	MVOUT(C.OUT)	Set output quantity in MAN
D0107	C.OUT	Set cooler output quantity in MAN
D0116	PWR.M	Set operation after blackout
D0121	AT	Set auto tuning operation
D0122	AT-G	Set AT gain value
D0131	S-TM	Set wait time to operation during reserved operation
D0132	P-TM	Set operating time
D0134	ON/OFF	Set ON/OFF control
D0135	US1	User screen registration 1
D0136	US2	User screen registration 2
D0137	LOCK	Set key lock
D0138	DI,SL	Set external contact input
D0139, D0140	DSP.H, DSP.L	Set upper/lower limits of sensor input values

6.3. SET POINT GROUP

- Set Point Group is composed of D-Registers pertinent to set values.

D-Reg.	Symbol	Description
D0200	SP,SL	Set SP type
D0201~D0204	SP1 ~ SP4	Set values of Set Value 1~4
D0211, D0212	SP.RH, SP.RL	Set upper/lower limits of Set Values
D0214	TM.U	Set time unit for time-related parameters
D0216	U.SLP	Increasing SLOPE Set Value
D0217	D.SLP	Decreasing SLOPE Set Value

6.4. SIGNAL/TIMER GROUP

- SIGNAL Group is composed of D-Registers for setting Inner Signal.

D-Reg.	Symbol	Description
D0301	1.IST	Set type of Inner Signal 1
D0302	1.ISB	Set direction of Inner Signal 1
D0303	1.SIH	Set upper limit of Inner Signal 1
D0304	1.ISL	Set lower limit of Inner Signal 1
D0305	1.ISD	Set delay time of Inner Signal 1
D0306	2.IST	Set type of Inner Signal 2
D0307	2.ISB	Set direction of Inner Signal 2
D0308	2.SIH	Set upper limit of Inner Signal 2
D0309	2.ISL	Set lower limit of Inner Signal 2
D0310	2.ISD	Set delay time of Inner Signal 2
D0311	1.TM.S	Set source of Timer 1
D0312	1.TM.T	Set type of Timer 1
D0313	1.TM.1	Set Time 1 for Timer 1
D0314	1.TM.2	Set Time 2 for Timer 1
D0315	2.TM.S	Set source of Timer 2
D0316	2.TM.T	Set type of Timer 2
D0317	2.TM.1	Set Time 1 for Timer 2
D0318	2.TM.2	Set Time 2 for Timer 2
D0319	1.TM.U	Set time unit for Timer 1
D0320	2.TM.U	Set time unit for Timer 2

6.5. ALARM GROUP

- ALARM Group is composed of D-Registers for setting alarms.

D-Reg.	Symbol	Description
D0401~D0404	ALT1 ~ ALT4	Set types of Alarm 1~4
D0406~D0409	AL1 ~ AL4	Set alarm values of Alarm 1~4
D0411~D0414	A1.DB ~ A4,DB	Set dead bands of Alarm 1~4
D0416~D0419	A1.DY ~ A4,DY	Set delay times of Alarm 1~4
D0421~D0424	A1.H ~ A4,H	Set upper deviation limit for Alarm 1~4
D0426~D0429	A1.L ~ A4,L	Set lower deviation limit for Alarm 1~4
D0430	SK,DV	Set alarm deviation for maintenance section
D0432	HB,CS	Set set value for heater break alarm
D0433	HB,DB	Set dead band of heater break alarm
D0434	PWR,F	Set power frequency of heater break alarm
D0435	CT,R	Set sensor current step-up ratio for heater break alarm
D0436	LBA,U	Set use of loop break alarm
D0437	LBA,D	Set dead band of loop break alarm
D0438	LBA,T	Set time for loop break alarm
D0440	AL1.SPH	Alarm1 set high deviation
D0441	AL2.SPH	Alarm2 set high deviation
D0442	AL3.SPH	Alarm3 set high deviation
D0443	AL4.SPH	Alarm4 set high deviation
D0445	AL1.SPL	Alarm1 set low deviation
D0446	AL2.SPL	Alarm2 set low deviation
D0447	AL3.SPL	Alarm3 set low deviation
D0448	AL4.SPL	Alarm4 set low deviation
D0450	B,GRP	Set bar graph type(0:MV, 1:CUR)
D0451	HB,BH	Set heater break graph high
D0452	HB,BL	Set heater break graph low
D0454~D0547	AL1.MODE~AL4.MODE	Set Alarm mode 1~4(0:ALWA, 1:RUN)
D0459~D0462	VAL.1.P~VAL4.P	[Position proportional control] Set valve alarm value 1~4
D0464~D0467	VAL1.DB~VAL4.DB	[Position proportional control] Set valve alarm dead band 1~4

6.6. PID GROUP

- PID Group is composed of D-Registers for PID setting.

D-Reg.	Symbol	Description
D0501	ARW	Set deviation to prevent overload
D0502	FUZZY	Set use of FUZZY function
D0503	C.MOD	Set operating mode under PID control
D0511	1. P	Set proportional constant for PID1
D0512	1. I	Set intergration time for PID1
D0513	1. D	Set derivative time for PID1
D0514	1. MR	Manually set integration time for PID1
D0515	1. P _C	Set proportional construct for cooler PID1
D0516	1. I _C	Set integration time for cooler PID1
D0517	1. D _C	Set derivative time for cooler PID1
D0518	1. DB	Set heating/cooling dead band for PID1
.	.	.
.	.	.
D0541	4. P	Set proportional constant for PID4
D0542	4. I	Set intergration time for PID4
D0543	4. D	Set derivative time for PID4
D0544	4. MR	Manually set integration time for PID4
D0545	4. PC	Set proportional construct for cooler PID4
D0546	4. IC	Set integration time for cooler PID4
D0547	4. DC	Set derivative time for cooler PID4
D0548	4. DB	Set heating/cooling dead band for PID4
D0519	1. RP	Set PID1 section
D0529	2. RP	Set PID2 section
D0539	RP.HY	Set hysteresis when selected PID Group in PID
D0549	RDV	Set deviation of PID

6.7. IN/OUT GROUP

- IN/OUT Group is composed of D-Register for setting input and control output.

D-Reg.	Symbol	Description
D0601	IN-T	Set sensor type
D0602	IN-U	Set sensor unit
D0603, D0604	IN.RH, IN.RL	Set upper/lower limits of input range
D0605	IN.DP	Set decimal place
D0606, D0607	IN.SH, IN.SL	Set upper/lower limits of input scale
D0608	IN.FL	Set measurement value filter
D0609	B.SL	Select Burn-Out
D0610	R.SL	Select reference contact compensation function
D0611 ~ D0613	BS.P1 ~ BS.P3	Set piece bias 1~3 to set bias values
D0615 ~ D0619	BS0~ BS4	Set piece bias 0~4 to set bias ranges
D0621	AL.BS	Set offset for all bias
D0622	D.FL	Select filter function for measured values
D0624 ~ D0625	OUT1, OUT2	Set OUT1, OUT2 operation
D0627 ~ D0630	EV1 ~ EV4	Set output operation for EVENT 1~4
D0631, D0633	HEAT1, HEAT2	Set output type for OUT1, 2(Heating)
D0632, D0634	COOL1, COOL2	Set output type for OUT1, 2(Cooling)
D0637	O.ACT	Set control output operation (Forward / Reverse)
D0638	CT	Set output cycle
D0639	CT _c	Set cooler output cycle
D0641, D0642	OH, OL	Set upper/lower limits for control output
D0644	HYS	Set hysteresis during ON/OFF control output
D0646	PO	Set emergency output value
D0647	PO _c	Set output value during cooling emergency
D0648, D0649	HYS.H, HYS.L	Set hysteresis upper/lower temp range under ON-OFF control
D0651	RET.T	Set transmission output type
D0652, D0653	RET.H, RET.L	Set transmission output upper/lower limits
D0655	OPR	Set output process rate
D0657	O.LED	Set MV OUT lamp operation
D0685	V.TT	[Position proportional control] Set valve travel time
D0686	V.HYS	[Position proportional control] Set hysteresis during valve output
D0687	V.DB	[Position proportional control] Set dead band during valve output
D0688	V.PDB	[Position proportional control] Set PV dead band
D0689	V.PHS	[Position proportional control] Set PV hysteresis
D0690	V.CMD	[Position proportional control] Set Valve control mode (0:FB.C, 1:FB.VC, 2:VRT.C)
D0691	V.A/M	[Position proportional control] Set valve auto/man(0:AUTO, 1:MAN)
D0692	V.CAL	[Position proportional control] Set valve auto calibration(0:OFF, 1:ON)

6.8. COMM GROUP

- COMM Group is composed of D-Registers for setting communication and checking current set values.

D-Reg.	Symbol	Description
D0661	COM.P	Set communication protocol
D0662	BAUD	Set communication speed
D0663	PRTY	Set parity bit
D0664	S.BIT	Set stop bit
D0665	D.LEN	Set data length
D0666	ADDR	Set communication address
D0667	RP.TM	Set response time
D0668	RBS	Set value added to SLAVE during cooperative operation
D0673	COM.P	Read communication protocol
D0674	BAUD	Read communication speed
D0675	PRTY	Read parity bit
D0676	S.BIT	Read stop bit
D0677	D.LEN	Read data length
D0678	ADDR	Read communication address
D0679	RP.TM	Read response time

6.9. PLC GROUP

- PLC Group is composed of D-Register to set programless communication.

D-Reg.	Symbol	Description
D0710	SW.TM	Set send delay time
D0711	RW.TM	Set receive wait time
D0712	MU.NO	Set max number of connection
D0713	R.TYP	Set register type
D0714	S.ADR	Set start address
D0715	MAP.S	Set Data map
D0716~D0728	RO.01~RO.13	Set read area address 1 ~13
D0729~D0743	RW.01~RW.15	Set read / write area address 1 ~15

6.10. NPL GROUP

- NPL Group is composed of D-Register that can check the current set value used during Programless Communication

D-Reg.	Signs	Description
D0751	N.SWT	Send delay time
D0752	N.RWT	receive waiting time
D0754	N.RTY	Register type
D0755	N.SAD	Start address
D0757~D0769	N.O01~N.O13	Read area address 1 ~ 13
D0770~D0784	N.W01~N.W15	Read/write area address 1~15

6.11. D-Register Table

D-Reg.	PROCESS	FUNCTION	SET POINT	SIGNAL	ALARM	PID	IN/OUT	PLC
	0	100	200	300	400	500	600	700
0			SP.SL					
1	NPV	STOP/RUN	SP1	1.IST	ALT1	ARW	IN.T	
2	NSP		SP2	1.ISB	ALT2	FUZZY	IN.U	
3	TSP		SP3	1.ISH	ALT3	C.MD	IN.RH	
4			SP4	1.ISL	ALT4		IN.RL	
5	SP.SL	AUTO/MAN		1.ISD			IN.DP	
6	MVOUT	MVOUT(H.OUT)		2.IST	AL1		IN.SH	
7	H.OUT	C.OUT		2.ISB	AL2		IN.SL	
8	C.OUT			2.ISH	AL3		IN.FL	
9	PID.NO.			2.ISL	AL4		B.SL	
10	NOW.STS			2.ISD			R.SL	SW.TM
11			SP.RH	1.TM.S	A1.DB	1.P	BS.P1	RW.TM
12			SP.RL	1.TM.T	A2.DB	1.I	BS.P2	MU.NO
13				1.TM.1	A3.DB	1.D	BS.P3	R.TYPE
14	ALM.STS		TM.U	1.TM.2	A4.DB	1.MR		S.ADR
15	DI.STS			2.TM.S		1.PC	B50	MAP.S
16		PWR.M	U.SLP	2.TM.T	A1.DY	1.IC	B51	RO.01
17	SIG.STS		D.SLP	2.TM.1	A2.DY	1.DC	B52	RO.02
18				2.TM.2	A3.DY	1.DB	B53	RO.03
19	ERROR			1.TM.U	A4.DY	1.RP	B54	RO.04
20	PROC.TIME			2.TM.U				RO.05
21	VVP	AT			AL1.H	2.P	AL.B5	RO.06
22		AT-G			AL2.H	2.I	D.FL	RO.07
23					AL3.H	2.D		RO.08
24					AL4.H	2.MR	OUT1	RO.09
25						2.PC	OUT2	RO.10
26					AL1.L	2.IC		RO.11
27					AL2.L	2.DC	EV1	RO.12
28					AL3.L	2.DB	EV2	RO.13
29					AL4.L	2.RP	EV3	RW.01
30	HB.CD				SK.DV		EV4	RW.02
31		S-TM				3.P	HEAT1	RW.03
32		P-TM			HB.CS	3.I	COOL1	RW.04
33					HB.DB	3.D	HEAT2	RW.05
34		ON/OFF			PWR.F	3.MR	COOL2	RW.06
35		US1			CT.R	3.PC		RW.07
36		US2			LBA.U	3.IC		RW.08
37		LOCK			LBA.D	3.DC	O.ACT	RW.09
38		DI.SL			LBA.T	3.DB	CT	RW.10
39		DSP.H				RP.HY	CTC	RW.12
40		DSP.L			AL1.SPH			RW.13
41					AL2.SPH	4.P	OH	RW.14
42					AL3.SPH	4.I	OL	RW.15
43					AL4.SPH	4.D		
44						4.MR	HYS	
45					AL1.SPL	4.PC		
46					AL2.SPL	4.IC	PO	
47					AL3.SPL	4.DC	POC	
48					AL4.SPL	4.DB	HYS.H	
49						RDV	HYS.L	

D-Reg.	PROCESS	FUNCTION	SET POINT	SIGNAL	ALARM	PID	IN/OUT	PLC
	0	100	200	300	400	500	600	700
50					B.GRP			
51					HB.BH		RET.T	N.SWT
52					HB.BL		RET.H	N.RWT
53							RET.L	
54					AL1.MODE			N.RTY
55					AL2.MODE		OPR	N.SAD
56					AL3.MODE			
57					AL4.MODE		O.LED	N.001
58								N.002
59					VAL1.P			N.003
60								N.004
61					VAL3.P		COM.P	N.005
62					VAL4.P		BAUD	N.006
63							PRTY	N.007
64					VAL1.DB		S.BIT	N.008
65					VAL2.DB		D.LEN	N.009
66					VAL3.DB		ADDR	N.010
67					VAL4.DB		RP.TM	N.011
68							RBS	N.012
69								N.013
70								N.W01
71								N.W02
72								N.W03
73							COM.P	N.W04
74							BAUD	N.W05
75							PRTY	N.W06
76							S.BIT	N.W07
77							D.LEN	N.W08
78							ADDR	N.W09
79							RP.TM	N.W010
80								N.W011
81								N.W012
82								N.W013
83								N.W014
84							V.CT	N.W015
85							V.TT	
86							V.HYS	
87							V.DB	
88							V.PDB	
89							V.PHS	
90							V.CMD	
91							V.A/M	
92							V.CAL	
93								
94								
95								
96								
97								
98								
99								