

NOVA500^e SERIES

Instruction Manual SS510^e (Signal Converter)



WELCOME

Thank you for purchasing furnace controller production.
Please use after read instruction manual for safety.
Free to contact our sales Div. for
production inquiry and after service.

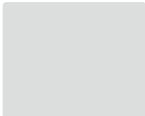

Various



As a signal converter, it supports a variety of input and output signal conversion and output signal conversion, a product with a display function can then Min, Max value memory.



Copyright

Copyright© 2016 Samwon technology Co., Ltd

This operation manual is a work protected by the copyright law. A part or entire of this manual shall not be copied, air sent, distributed, translated or changed into the form to be read by electronic media or machine without prior written consent of Samwon technology Co., Ltd.



MSP-REM-S31-
NOVAESERIES

Part **I** **Instruction
Manual**



Safety Guide

Used symbol mark in this Instruction manual



- It means the "Handle with care" or "Cautions"

In case of violation of this point, it may cause the death, severe injury or the extreme damage on the product.

- (1) Product : It is marked on the points to be acknowledged certainly to protect the human body and device.
- (2) Instruction manual : It describes the cautions to prevent the cases of endangered situation on the life and body of the user due to the electric shock and so on.



- It means "Ground terminal"

Make the earth with the ground in case of product installation and controlling the product.



- It means the "supplementary explanation"

It describes the points to supplement the explanation.



- It describes the "references"

It describes the information and pages of reference to be referred.

Cautions in this Instruction manual

- Please deliver for the end user to possess always and keep it in the place accessible at any time.
- Use the product after full understanding of this installation manual.
- This installation manual does not warrant any other things because it is a description of the details for the function.
- A part or whole of this manual shall not be edited or copied randomly.
- The descriptions in this manual may be changed randomly without pre notice or warning.
- Even though this manual was made with elaboration, it will be appreciated if you inform to the purchasing point (Dealer shop and etc) or sales team in our company in case of deficiency, mistake or omission in the contents.

Safety Guide

Cautions for the safety and modification (Change) of the product

- Please use this product after full understanding on the safety cautions in this manual for the protection and safety for this product and the system connected to this system.
- Our company is not responsible to the damages occurred by using or handling or unattended using not relying on this installation manual.
- Please install at the outside of this product when the additional protection and safety circuit is installed. Separately for the protection and safety for this product and the system connected to this system.
- The internal modification (Change) and addition to this product are prohibited.
- Do not disassemble, repair and modify of this product because it becomes the reasons for electric shock, fire and malfunction.
- In case of changing the part or the consumables of this product, please contact to the sales department of our company.
- Do not contact to the moisture with this product. It may cause the failure on this product.
- Do not apply the strong impact on this product. It may cause the damage and failure on this product.

With regard to the exemption for the responsibility of this product

- We are not responsible for any warranty on this product besides the defined cases in the quality assurance condition of our company.
- We are not responsible for the direct or indirect damages on the user of any third party due to the not expectable defect or the natural disaster in use of this product.

With regard to the quality assurance condition of this product

- The warranty period shall be one year from the purchasing of this product. Free of charge repair is available only for the cases of out of order occurred from normal use conditions.
- The repair due to the out of order occurred after the warranty period shall be repaired at the actual cost according to the defined condition by our company.
- The out of order occurred within the warranty period shall be repaired at the actual cost for the following cases in spite of within the warranty period.
 - (1) Out of order due to the mistake or fault of the user (Ex: Initialization by losing the password and etc.)
 - (2) Out of order due to the natural disaster(Ex: Fire and flood and etc)
 - (3) Out of order due to the movement of product after installation.
 - (4) Out of order due to the random disassemble, change or damage on the product.
 - (5) Out of order due to the electric power instability.
 - (6) Others
- Please contact to the purchasing points or sales part of our company when after sales service is necessary because of the failure on the product.

Safety Guide

Environmental precautions for installation.

- Be sure to operate the controller installed on a panel to prevent electric shock.
- To install the controller, do select a location where:
 - (1) No one may accidentally touch terminal.
 - (2) Mechanical vibrations are minimal.
 - (3) No corrosive gas is present.
 - (4) Temperature fluctuation is minimal.
 - (5) Temperature can be maintained. (50 °C below / 10 °C over)
 - (7) No direct heat radiation is present.
 - (8) No magnetic disturbances are caused
 - (9) No water is splashed.
 - (10) No flammable materials are around.
 - (11) No wind blows. (prevent Dust with salt)
 - (12) No ultraviolet rays are present.

Precautions of Controller Mounting.

- Keep the input circuit wiring as far as possible away from power and ground circuit.
- Keep the controllers in 10°C ~ 50°C/ 20 % ~ 90 % RH, Warming up needed to use controller when temperature is below 10°C in advance.
- Do not mount front panel facing downward.
- To prevent electric shock, be sure to turn off and the source circuit breaker before wiring.
- The power consumptions are 100-240VAC, 50/60Hz, 10VAmax and operate without power switching in advance.
- No work in wet hands (it caused electric shock)
- Follow operation by precaution in the manual to avoid fire, electric shock, loss of life etc.
- Requested to follow mounting and operation methods just indicated in this manual.
- Refer the way of grounding connection, however, keep away for grounding to Gas pipe, water pipe, lightning rod etc.
- Be sure not to power connection before finishing of wiring between each contact point.
- Not close and wrapping the heat hole in back case of controller.



Rated Voltage and Power Consumption

- This product runs on 24V DC, 3.2VA Max.
 - Risk of electric shock and fire if use power source in rating other than specified.
-

Engineering Units - EU, EUS

- EU and EUS are used for the scaling of the parameters of the controller.
- When the sensor type (IN-T) or the high limit, low limit of input range is changed, the parameters expressed in EU(), EUS() are changed in proportion to current data. (However, the high/low range setting data is initialized.)

☞ EU() : Value of engineering unit depending on the range of instrument

☞ EUS() : Value of engineering unit depending on the span of instrument

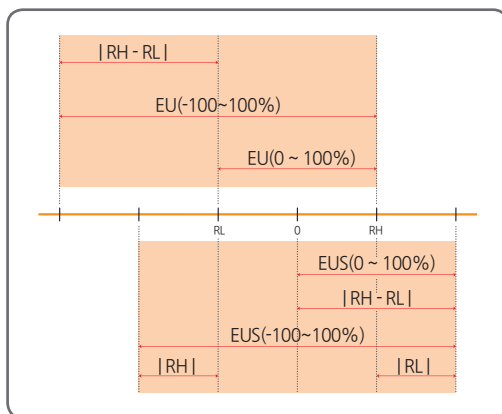

RL : Low limit of input range

RH : High limit of input range

※ The Range of EU(), EUS()

	Range	Center point
EU(0 ~ 100%)	RL ~ RH	$ RH - RL /2 + RL$
EU(-100 ~ 100%)	$-(RH - RL + RL) \sim RH$	RL
EUS(0 ~ 100%)	$0 \sim RH - RL $	$ RH - RL /2$
EUS(-100 ~ 100%)	$- RH - RL \sim RH - RL $	0

※ Ex) INPUT = TC.K2

RANGE = -200.0°C(RL) ~ 1370.0°C(RH)

	Range	Center point
EU(0 ~ 100%)	-200.0 ~ 1370.0°C	585.0°C
EU(-100 ~ 100%)	-1770.0 ~ 1370.0°C	-200.0°C
EUS(0 ~ 100%)	0 ~ 1570.0°C	785.0°C
EUS(-100 ~ 100%)	-1570.0 ~ 1570.0°C	0.0°C

Displays of the product

Numbers · Character in 7-Segment

- Numbers · Character in 7-Segment LED Display

0	1	2	3	4	5	6	7
0	1	2	3	4	5	6	7
8	9	.	-	/	Half -	Half 1	Half -1
8	9	.	-	/	Half -	Half 1	Half -1

Alphabets in 7-Segment

- Alphabets in 7-Segment LED Display

A, a	B, b	C, c	D, d	E, e	F, f	G, g	H, h
A, a	B, b	C, c	D, d	E, e	F, f	G, g	H, h
I, i	J, j	K, k	L, l	M, m	N, n	O, o	P, p
I, i	J, j	K, k	L, l	M, m	N, n	O, o	P, p
Q, q	R, r	S, s	T, t	U, u	V, v	W, w	X, x
Q, q	R, r	S, s	T, t	U, u	V, v	W, w	X, x
Y, y	Z, z						
Y, y	Z, z						



Precautions
Numeric 5 and alphabet S appear the same way

Contents

I Instruction Manual	1
1. Product Dimensions and Installation	8
1.1. Dimension and Panel Cutout.....	8
1.2. How to install Mount	9
1.3. Power Cable Specification	10
1.4. Terminal Specification	10
1.5. Dimension and Panel Cutout.....	11
1.6. Power Cable Wiring	12
1.7. Analog Input Wiring.....	13
1.7.1. RTD Input	13
1.7.2. DC Voltage Input	13
1.7.3. DC Current Input	13
1.8. Retransmission Output Wiring	14
1.9. Communication Wiring (RS485)	15
1.10. Multi Connection Wiring.....	15
2. Control Keys and Display	16
3. Flow of Operating Display	17
4. Parameter Map	18
5. Setting Up Parameter in each Group	20

Contents

5.1. Control Functions Group(G.CTL)	20
5.1.1. PV High/Low Display	20
5.1.2. Min/Max Initialization	20
5.1.3. User Screen Setting	21
5.1.4. PV Display High/Low Limit Setting	21
5.1.5. Key Lock Setting	22
5.1.6. Password Setting	22
5.1.7. Initialization of The Controller	22
5.2. Input Group(G.IN)	23
5.2.1. Input Type Setting	23
5.2.2. Input Unit Setting	23
5.2.3. Input Range Setting	25
5.2.4. Decimal Point Setting	25
5.2.5. PV Display Range Setting	26
5.2.6. Input Filter Setting	26
5.2.7. Display Filter Setting	27
5.2.8. PV Direction Setting during Sensor-Open	27
5.2.9. Reference Junction Compensation Setting	27
5.2.10. All Bias Setting	28
5.2.11. Piece Bias Setting	28
5.3. Retransmission Group(G.RET)	31
5.3.1. High/Low Limits of Retransmission Setting	31
5.4. Communication Group(G.COM)	32
5.5. PLC Group(G.PLC)	34
5.6. Now PLC Display Group(G.NPL)	37
6. Display Error and Correction	39
II Communication Manual	41

1. Product Dimensions and Installation

1.1. Dimension and Panel Cutout

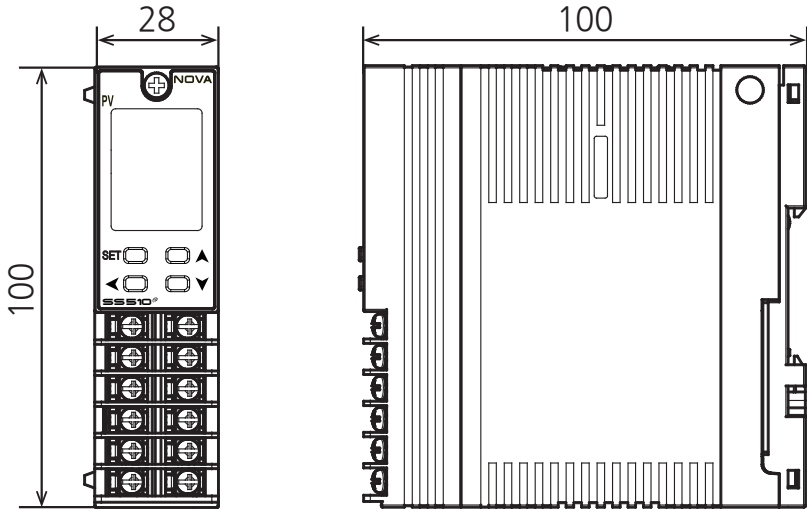

1.2. How to install Mount

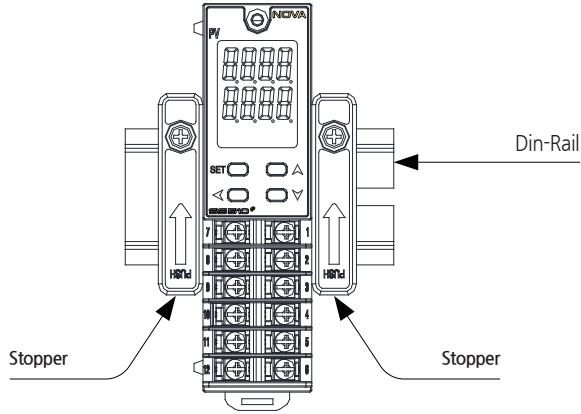

- It should be installed using a Din-Rail stopper.

Caution when fastening the mount



- Do not apply excessive force when fastening the mount on the account that the part may become damaged.
- Max torque when fastening the mount should not exceed $0,25N \cdot m$.

1.3. Power Cable Specification

- Vinyl insulated wire 0.9~2.0mm

1.4. Terminal Specification

- Use M3 screw-compatible crimp-on terminals with insulating sleeve as shown below.

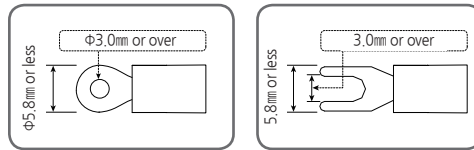

- First Turn off the source circuit breaker, check to ensure that the power cable is not conducting electricity using a tester, and then proceed with wiring in the manner.
 - Never touch the terminal in the rear panel to prevent electric shock when power is supplied to the controller.
 - Be sure to turn off the electric power before wiring.
- Bind the wires connected to the controller terminals neatly together in order to prevent electromagnetic wave radiation.
- Recommended tightening torque : 0.4N·m ~ 0.55N·m

1.5. Dimension and Panel Cutout

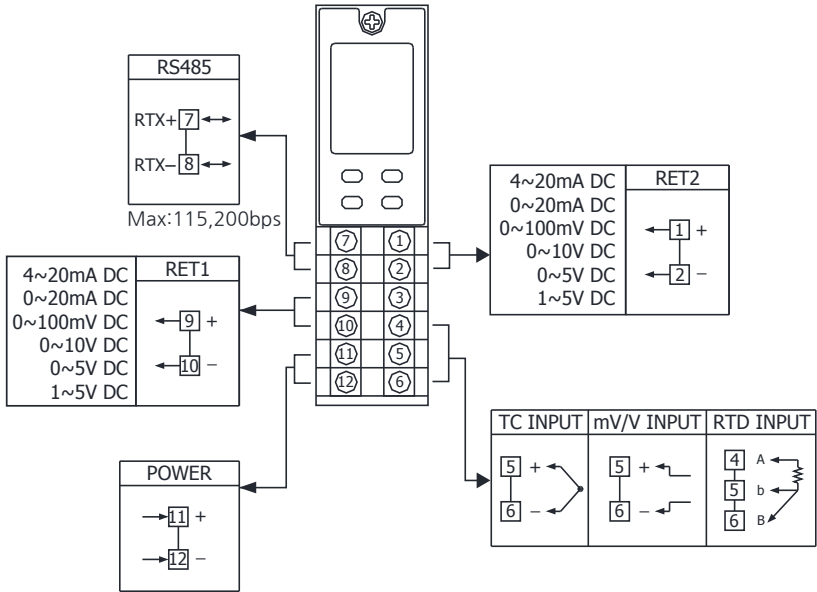

1.6. Power Cable Wiring

- Use Vinyl insulation wire (KSC 3304) or higher leveled cable for power cable connection.
- Use the main power disconnect device in case of abnormal situations occur.

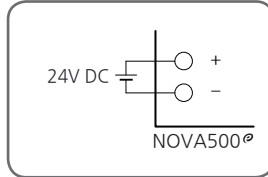

- For power connection, make sure that N-phase and L-phase are connected.
- Turn off the power of NOVA500[®] when wiring the terminal to prevent electrical shock.

1.7. Analog Input Wiring



- Be sure to connect to correct polarities, Connecting to a wrong polarity may cause unexpected malfunction.
- Use shielded wires and ground the shielding to an independent grounding point.
- Keep the input circuit wiring as far as possible away from the power and ground circuit.
- Use a wire having a low conductor resistance and no three-wire resistance differential.

1.7.1. RTD Input

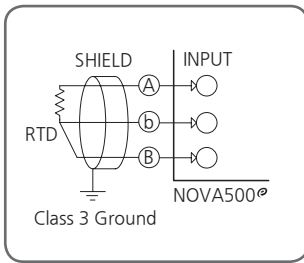

1.7.2. DC Voltage Input

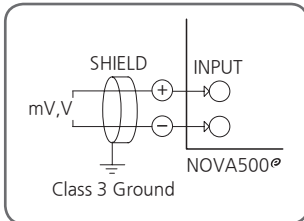

1.7.3. DC Current Input

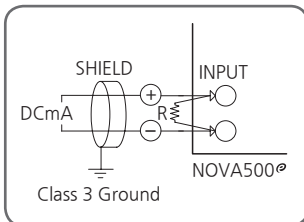

1.8. Retransmission Output Wiring



- To prevent electric shock, be sure to turn off the NOVA500[®] Controller and the source circuit breaker before wiring.
- Be sure to connect to correct polarities. Connecting to a wrong polarity may cause serious trouble.
- Use shielded wires for the wiring and, Be sure to connect independently(1 point grounding)

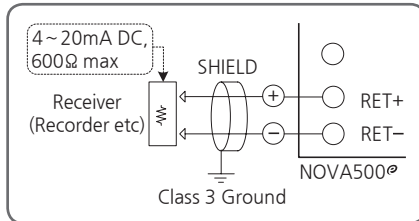

▲ Retransmission Output(RET)



To prevent electric shock, be sure to turn off the NOVA500[®] controller and the source circuit breaker before connection/disconnection of the receiver as well as wiring.

1.9. Communication Wiring (RS485)

- Up to 31 slave controllers (NOVA500[®]) series instruments equipped with communication option can be multidrop-connected.
- Be sure to connect terminating resistors (220Ω, 1/4W) to slave and master controllers at communication-channel ends as shown above.

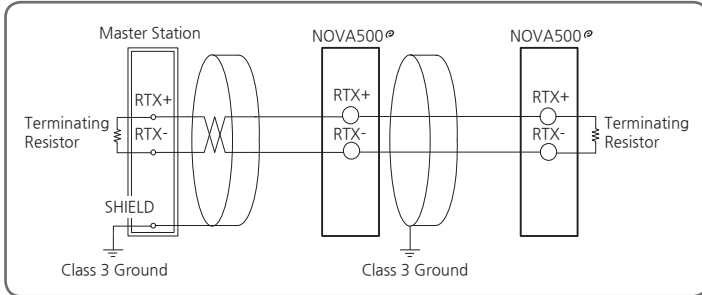

To prevent electric shock, be sure to turn off the NOVA500[®] control and source circuit breaker before Communication wiring.

1.10. Multi Connection Wiring

- If the multi option, because power and communication signals are internally connected. Only one unit may be wiring.
- It can connect up to 10 multi connections.

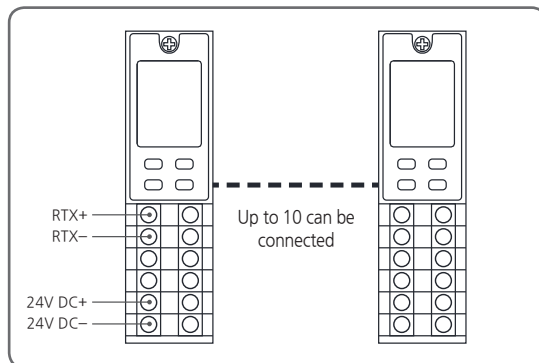

2. Control Keys and Display

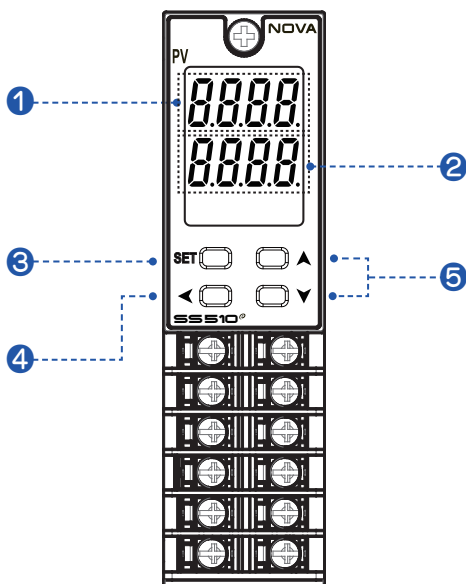

No.	Contents
①	PV display, Parameter Symbol
②	Parameter Set
③	<ul style="list-style-type: none"> • Used in switching between parameters or registering parameter settings. • Used to change Display screen from RUN screen. • Pressing the SET key for 3 sec from the RUN screen. → Move to the SET screen. • Pressing the SET key for 3 sec from the SET screen. → Move to the RUN screen.
④	Used when shifting position to modify value
⑤	Used to change the value of parameters. Used to move between Group

3. Flow of Operating Display

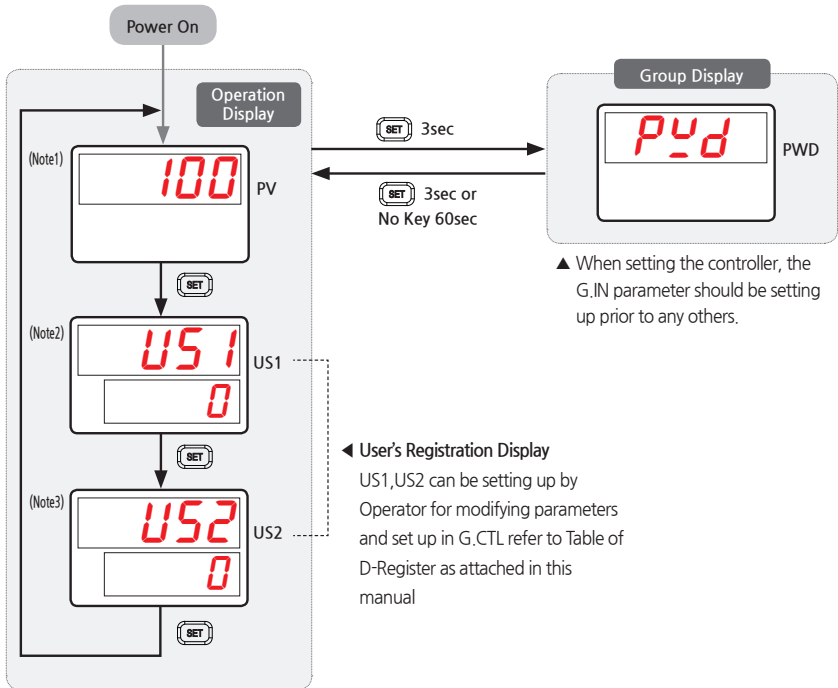

(Note1) : Run 1 Screen Initial display after power on

(Note2) : If the User Screen1 is set

(Note3) : If the User Screen2 is set

4. Parameter Map

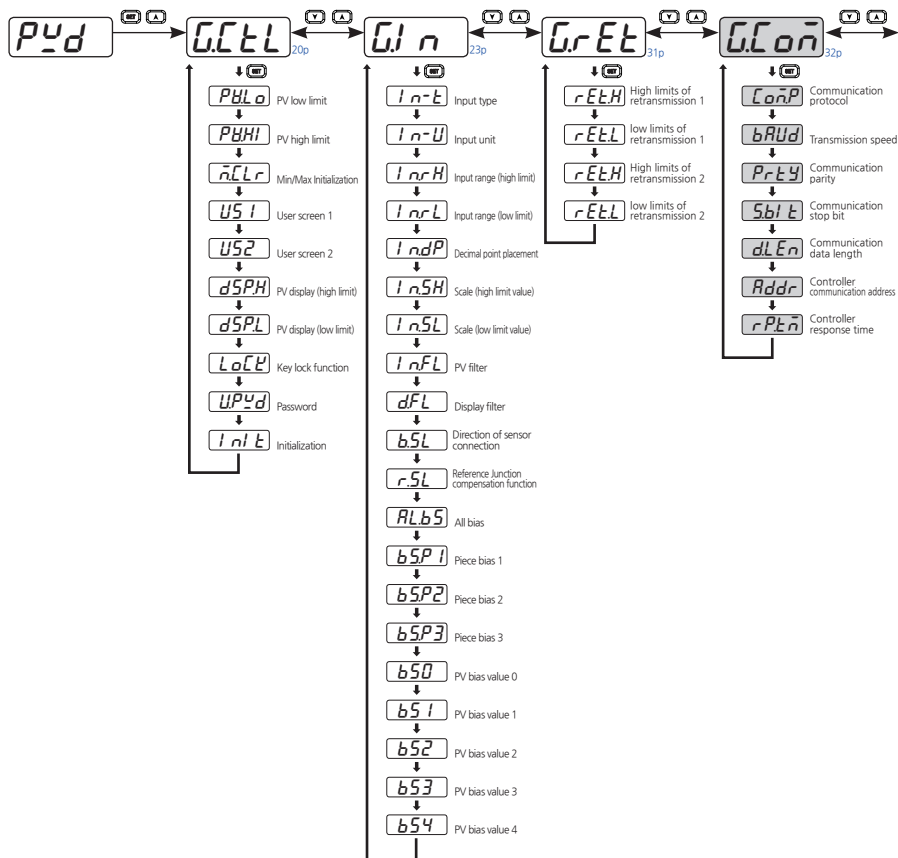

 : Option

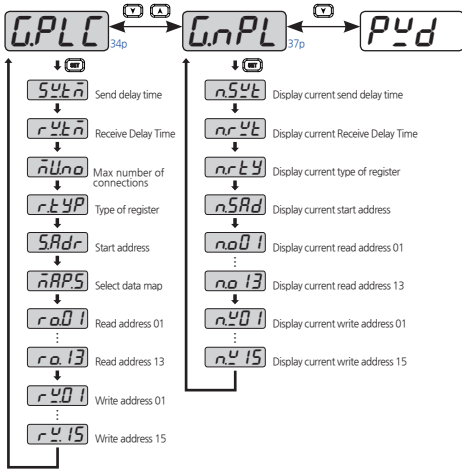

5. Setting Up Parameter in each Group

5.1. Control Functions Group(G.CTL)



- Parameter for setting control parameters.

5.1.1. PV High/Low Display



- Parameter for setting PV input values of low limits. (It is initialized at Power On/Off.)



- Parameter for setting PV input values of high limits. (It is initialized at Power On/Off.)

Symbol	Parameter	Setting range	Unit	Default	Display
PV.LO	PV Low Value	EU(-5.0 ~ 105.0%)	EU	EU(100.0%)	Always
PV.HI	PV High Value	EU(-5.0 ~ 105.0%)	EU	EU(0.0%)	Always

5.1.2. Min/Max Initialization



- Parameter for setting Clear PV.LO, PV.HI of PV value.

Symbol	Parameter	Setting range	Unit	Default	Display
M.CLR	Min Max Clear	OFF, ON	ABS	OFF	Always

5.1.3. User Screen Setting



- Parameter for setting user screen to display most frequently used parameters on screen.
- Refer to Communication Manual D-Register to input.



Symbol	Parameter	Setting range	Unit	Default	Display
US1	User Screen1	OFF, D-Register No.(0001 ~ 1299)	ABS	OFF	Always
US2	User Screen2	OFF, D-Register No.(0001 ~ 1299)	ABS	OFF	Always

5.1.4. PV Display High/Low Limit Setting



- Parameter for setting high/low limits of sensor input values on PV screen.
- Only values on and within DSP.H / DSP.L will be displayed on PV screen, although exceeding values are input from the sensor.
- However, the controller will operate according to the actual sensor values.

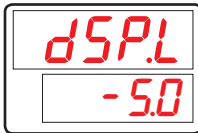

Symbol	Parameter	Setting range	Unit	Default	Display
DSP.H	Display High Limit	EU(-5.0 ~ 105.0%) (DSP.L < DSP.H)	EU	EU(105.0%)	Always
DSP.L	Display Low Limit		EU	EU(-5.0%)	Always

5.1.5. Key Lock Setting

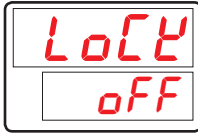

- Parameter to counteract irregular operations due to erroneous input keys.
- If LOCK is ON, all parameter settings become restricted including SP.

Symbol	Parameter	Setting range	Unit	Default	Display
LOCK	Key Lock	OFF, ON	ABS	OFF	Always

5.1.6. Password Setting



- Parameter for setting controller password.
- Once U.P.W.D is set, password must be entered to access Control Group (G.CTL). If you set a password and input values do not match, you can not enter the parameters of the group in the future.
- Default U.P.W.D password is '0'.

Symbol	Parameter	Setting range	Unit	Default	Display
U.P.W.D	User Password	0 ~ 9999	ABS	0	Always



- Do not forget your password.
- If the password is misplaced, the unit is inaccessible by users. Please send the unit to our service department.

5.1.7. Initialization of The Controller



- Parameter for initiating controller.
- All controller parameters are initialized by switching INIT to ON. (However, communication is not initialized.)

Symbol	Parameter	Setting range	Unit	Default	Display
INIT	Parameter Initialization	OFF, ON	ABS	OFF	Always



- Switching INIT to ON will initialize all controller parameters to default settings. Please be careful.

5.2. Input Group(G.IN)



■ Group of input parameters.

- ☞ Input Type (IN-T) : Thermocouple (TC), Resistive thermal detector (RTD), DC volt (DCV).
- ☞ In case of TC or RTD, the sensor type and temperature range should be selected.
- ☞ In case of DCV, the input types are classified with the range of input voltage.



Input Group parameter settings must be adjusted first as they can influence initialization of other group parameters.

5.2.1. Input Type Setting

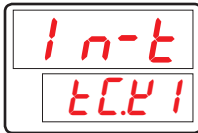

- Parameter for setting sensor input types.
- Refer to [Table 1] Sensor input types to adjust settings.

Symbol	Parameter	Setting range	Unit	Default	Display
IN-T	Input Sensor Type	For more detail, refer to [Table 1] Sensor input types	ABS	TC.K1	Always

5.2.2. Input Unit Setting

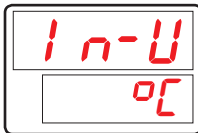

- Select “C” or “F” for input unit .
- Changing IN-U will automatically convert temperature ranges in appropriate unit.
- IN-U is only applicable when sensor type (IN-T) is TC or RTD.
- Refer to [Table 1] Sensor input types to check temperature settings.

Symbol	Parameter	Setting range	Unit	Default	Display
IN-U	Input Unit	°C / °F	ABS	°C	IN-T = TC or RTD



Once sensor type is changed, all parameters are initialized. (However, communication is not initialized.) Please be careful.

[Table1] Sensor input types

* Display range : -5% ~ +105%

Group	Symbol	Temp.Range(°C)	Temp.Range(°F)	Measurement Range
T/C	TC.K1	-200 ~ 1370	-300 ~ 2500	Range $\pm 0.1\% \pm 1$ digit for temperature greater than 0°C Range $\pm 0.2\% \pm 1$ digit for temperature less than 0°C
	TC.K2	-199.9 ~ 999.9	0 ~ 2300	
	TC.J	-199.9 ~ 999.9	-300 ~ 2300	
	TC.E	-199.9 ~ 999.9	-300 ~ 1800	
	TC.T	-199.9 ~ 400.0	-300 ~ 750	
	TC.R	0 ~ 1700	32 ~ 3100	Temperature range $\pm 0.15\% \pm 1$ digit
	TC.B	0 ~ 1800	32 ~ 3300	Range $\pm 0.15\% \pm 1$ digit for temperature greater than 400°C Range $\pm 5\% \pm 1$ digit for temperature less than 400°C
	TC.S	0 ~ 1700	32 ~ 3100	Temperature range $\pm 0.15\% \pm 1$ digit
	TC.L	-199.9 ~ 900.0	-300 ~ 1600	Range $\pm 0.1\% \pm 1$ digit for temperature greater than 0°C Range $\pm 0.2\% \pm 1$ digit for temperature less than 0°C
	TC.N	-200 ~ 1300	-300 ~ 2400	TRange $\pm 0.1\% \pm 1$ digit for temperature greater than 0°C Range $\pm 0.25\% \pm 1$ digit for temperature less than 0°C
	TC.U	-199.9 ~ 400.0	-300 ~ 750	Range $\pm 0.1\% \pm 1$ digit for temperature greater than 0°C Range $\pm 0.2\% \pm 1$ digit for temperature less than 0°C
	TC.W	0 ~ 2300	32 ~ 4200	Temperature range $\pm 0.2\% \pm 1$ digit
TC.PL	0 ~ 1390	32 ~ 2500	Temperature range $\pm 0.1\% \pm 1$ digit	
TC.C	0 ~ 2320	32 ~ 4200	Temperature range $\pm 0.2\% \pm 1$ digit	
RTD	PTA	-199.9 ~ 850.0	-300 ~ 1560	Temperature range $\pm 0.1\% \pm 1$ digit
	PTB	-199.9 ~ 500.0	-199.9 ~ 999.9	
	PTC	-19.99 ~ 99.99	-4.0 ~ 212.0	Inquire separately
	PTD	-199.9 ~ 850.0	-300 ~ 1560	Temperature range $\pm 0.1\% \pm 1$ digit
	JPTA	-199.9 ~ 500.0	-199.9 ~ 999.9	Temperature range $\pm 0.1\% \pm 1$ digit
	JPTB	-150.0 ~ 150.0	-199.9 ~ 300.0	Inquire separately
DCV	2V	0.400 ~ 2.000V(-1999 ~ 9999)		Temperature range $\pm 0.1\% \pm 1$ digit
	5V	1.000 ~ 5.000V(-1999 ~ 9999)		
	10V	0.00 ~ 10.00V(-1999 ~ 9999)		
	20MV	-10.00 ~ 20.00mV(-1999 ~ 9999)		
	100MV	0.0 ~ 100.0mV(-1999 ~ 9999)		

* Performance at standard operating status at 23 \pm 2°C, 55 \pm 10%RH, and 50/60Hz* When receiving 4~20mA DC signal, select DCV 5V (1~5V DC) and connect 250 Ω resistance.

5.2.3. Input Range Setting

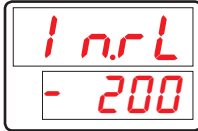

- Parameter for setting high/low limits for sensor input.
- TC, RTD Input
Once sensor type is selected, input range for TC and RTD will be determined according to [Table1] Sensor input types.
Input ranges for IN.RH and IN.RL can be changed within given range.
Decimal placement cannot be changed.
- DCV, mV Input
Determining input range after selecting a sensor type is the same for voltage input. Input ranges for IN.RH and IN.RL can be changed within given range.

Symbol	Parameter	Setting range	Unit	Default	Display
IN.RH	Input Range High	Refer to [Table1] Sensor input types within Input type. (IN.RH > IN.RL)	EU	EU(100%)	Always
IN.RL	Input Range Low		EU	EU(0.0%)	Always



Input range setting Example

- When using a range of [Table1] Sensor input types to select the thermocouple input range of -200 ~ 1370 °C hereafter, setting "500" to "-100", Low Range High Range setting items on the setting items, -100 ~ 500 °C this is limited.

5.2.4. Decimal Point Setting

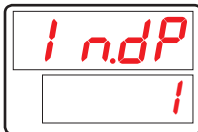

- Parameter for setting decimal placement, if sensor input type is mV or V.

Symbol	Parameter	Setting range	Unit	Default	Display
IN.DP	Input Dot Position	0~3	ABS	1	IN-T = DCV



Changing this parameter will change decimal placement for all parameters pertinent to PV, including those relevant to EU and EUS.

5.2.5. PV Display Range Setting

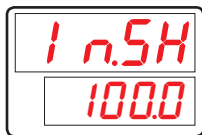

- Parameter for setting high limit for scale, if sensor input type is mV or V.

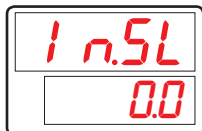

- Parameter for setting low limit for scale, if sensor input type is mV or V.

Symbol	Parameter	Setting range	Unit	Default	Display
IN.SH	Input Scale High	- 10000~19999, but INSH > INSL	ABS	100.0	IN-T = DCV
IN.SL	Input Scale Low	Decimal place will conform to IN.DP		0.0	IN-T = DCV



PV display range setting example

- Select the input voltage(V, mV) to the input type, and the range is 1~5V and scaled display need to be 0~100 IN-T : 5V.
- IN.SH : 100(5V input is scaled to "100" display).
- IN.SL : 0(1V input is scaled to "0" display).

5.2.6. Input Filter Setting

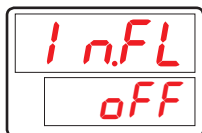

- Parameter for setting PV filter to moderate PV run-outs due to disturbance and noise.

Symbol	Parameter	Setting range	Unit	Default	Display
IN.FL	Input Sensor Filter	OFF, 1 ~ 120	ABS	OFF	Always

5.2.7. Display Filter Setting



- Parameter for moderating PV run-outs due to delicate sensor reaction under normal operation.

Symbol	Parameter	Setting range	Unit	Default	Display
D.FL	Display Filter	OFF, 1~120	ABS	OFF	Always

5.2.8. PV Direction Setting during Sensor-Open

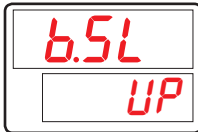

- Parameter for setting sensor direction during sensor-open.
- If B.SL value is UP, PV will operate upwards of sensor input. If B.SL value is DOWN, PV will operate downwards of sensor input.
- B.SL default setting is UP. (However, when input mV and V, it will be initialized to OFF. 10V, 20mV and 100mV will not be S.OPN checked.)

Symbol	Parameter	Setting range	Unit	Default	Display
B.SL	Burn Out Select (Note1)	OFF, UP, DOWN	ABS	UP (DCV=OFF)	Always

* (Note1) : S.OPN(Sensor-Open) = B.OUT(Burn-Out)

5.2.9. Reference Junction Compensation Setting

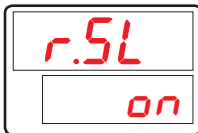

- Parameter for setting use of RJC (Reference Junction Compensation), in case the sensor input type is TC (thermocouple).

Symbol	Parameter	Setting range	Unit	Default	Display
R.SL	RJC Select	ON, OFF	ABS	ON	IN-T = TC

5.2.10. All Bias Setting

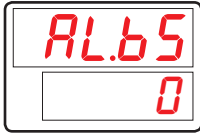

- Adjusts offsets of all bias values for PV display.
- PV display value = input value + all bias (AL.BS).

Symbol	Parameter	Setting range	Unit	Default	Display
AL.BS	All Bias Value	EUS(-100.0 ~ 100.0%)	EUS	EUS(0.0%)	Always

5.2.11. Piece Bias Setting

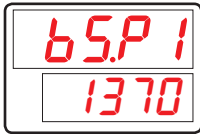

- Parameter for setting piece bias to set BIAS to PV value.
- Up to 4 references can be set for bias.
 - Reference 1 : IN,RL(IN,SL) ↔ BS,P1
 - Reference 2 : BS,P1 ↔ BS,P2
 - Reference 3 : BS,P2 ↔ BS,P3
 - Reference 4 : BS,P3 ↔ IN,RH(IN,SH)
- For more details, refer to [Fig.1] Example of Piece Bias and [Fig.2] Example of Piece Bias Formula .

Symbol	Parameter	Setting range	Unit	Default	Display
BS,P#n	Reference Bias Point	EU(0.0 ~ 100.0%) IN,RL ≤ BS,P1 ≤ BS,P2 ≤ BS,P3 ≤ IN,RH	EU	EU(100.0%)	Always

#n = 1~3



- Parameter for setting the PV value correction value(BIAS) to be applied to domestic correction.
- For more details, refer to [Fig.1] Example of Piece Bias and [Fig.2] Example of Piece Bias Formula .

Symbol	Parameter	Setting range	Unit	Default	Display
BS#n	Bias Value for BS,P Point	EUS(-100.0~100.0%)	EUS	0	Always

#n = 0~4



Example of Piece Bias

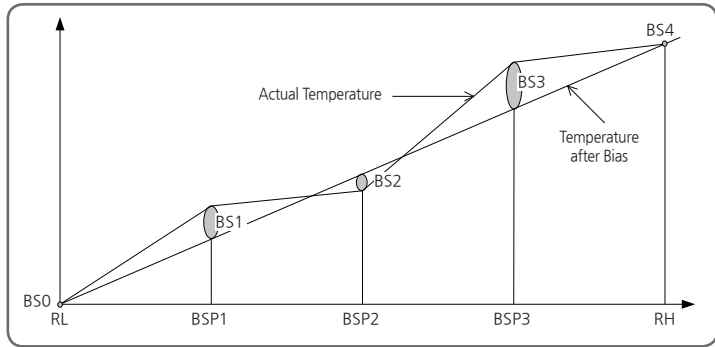

[Fig.1] Example of Piece Bias

- There are +2°C in 25°C, -1°C in 50°C, +3°C in 75°C as temperature deviation in measuring actual temperature in range from 0°C ~100°C, and try to take a Piece Bias, each Bias set value are shown as belows.

RL = 0°C, BSP1=25°C, BSP2=50°C, BSP3=75°C, RH=100°C

BS0 = 0°C, BS1=-2°C, BS2=+1°C, BS3=-3°C, BS4=0°C

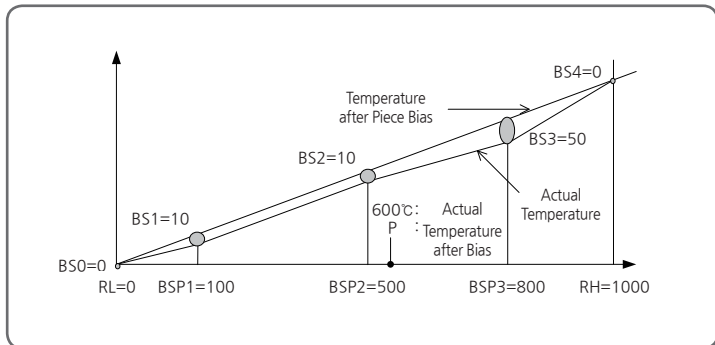

[Fig.2] Example of Piece Bias Formula

- Temperature Bias Value = Temperature after Bias - Actual Temperature
- Temperature in 600°C(P) after Bias

$$P = 600 + (600 - \text{BPS2}) \times \frac{\text{BS3} - \text{BS2}}{\text{BSP3} - \text{BSP2}} + \text{BS2}$$



NOTE

Processing PV Input

- If PV is less than EU(-5%) or greater than EU(-105%), PV will be -OVR or OVR.
- For internal operation, PV will be set -5%, 105% .
 - $PV > EU(105\%)$: PV = 105%, PV = OVR
 - $EU(-5\%) \leq PV \leq EU(105\%)$: PV = PV
 - $PV < EU(-5\%)$: PV = -5%, PV = -OVR

-
- All parameters are reset to change the sensor types.
(However, communication and A/M are not initialized.)
 - If you change the input type and input range, so the parameters, that is unit related to the input range is changed according to the EU or EUS parameters are input range should be set ahead of the sensor type parameter with units of the EU or EUS.



CAUTION

- **Setting Example**
 - Pt100 Ω sensor is used in the range of -50.0~500.0 $^{\circ}$ C and display 1 decimal place.
 - IN-T = PTA \rightarrow PTA (-200.0~850.0 $^{\circ}$ C range) uses a pressure sensor.
 - IN-U = $^{\circ}$ C \rightarrow Display unit is $^{\circ}$ C.
 - IN.RH = 500.0
 - IN.RL = -50.0

5.3. Retransmission Group(G.RET)

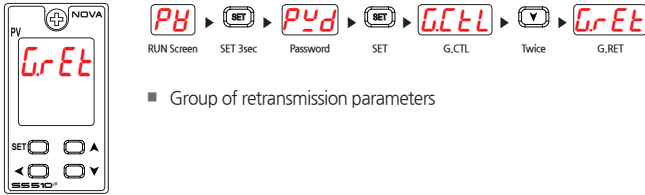

5.3.1. High/Low Limits of Retransmission Setting

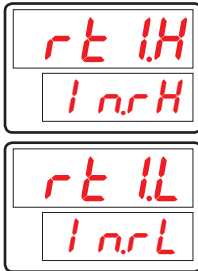

- Parameter for setting high/low limits for retransmission
- If type of retransmission output is PV or SP, high limit (20mA) and low limit (4mA) are set as RT#n.H and RT#n.L, respectively.

Symbol	Parameter	Setting range	Unit	Default	Display
RT#n.H	Retransmission High Limit	T/C, RTD : IN.RH ~ IN.RL mV, V : IN.SH ~ IN.SL (RT1.H > RT1.L)	EU	IN.RH	Always
RT#n.L	Retransmission Low Limit	T/C, RTD : IN.RH ~ IN.RL mV, V : IN.SH ~ IN.SL (RT1.H > RT1.L)	EU	IN.RL	Always

#n = 1~2

5.4. Communication Group(G.COM)



- Group of communication parameters
- For more details, refer to Communication Manual.



- Parameter for setting communication Protocol.

Symbol	Parameter	Setting range	Unit	Default	Display
COM.P	Communication Protocol	PCC0, PCC1, MBS.A, MBS.R, P.OMR, P.MIT, P.LG, P.YKO, P.KEN, P.SIE	ABS	PCC1	Option

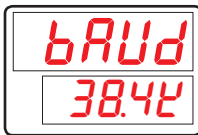

- Parameter for setting communication speed (BAUD RATE).

Symbol	Parameter	Setting range	Unit	Default	Display
BAUD	Baud Rate	9600, 19200, 38.4K, 57.6K, 115.2K	ABS	38.4K	Option

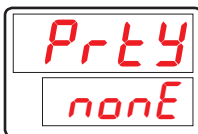

- Parameter for setting Communication Parity.

Symbol	Parameter	Setting range	Unit	Default	Display
PRTY	Parity	NONE, EVEN, ODD	ABS	NONE	Option

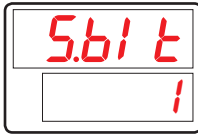

- Parameter for setting Communication Stop Bit.

Symbol	Parameter	Setting range	Unit	Default	Display
S.BIT	Stop Bit	1, 2	ABS	1	Option



- Parameter for setting Communication Data Length.
- Parameter 'D.LEN' is not display when 'COM.P' sets 'MODBUS ASCII' or 'RTU'

Symbol	Parameter	Setting range	Unit	Default	Display
D.LEN	Data Length	7, 8	ABS	8	Option and COM.P = PCC0, PCC1

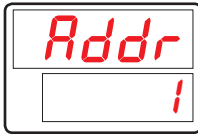

- Parameter for setting Communication Address for controller.

Symbol	Parameter	Setting range	Unit	Default	Display
ADDR	Address	1 ~ 99 (Max 31 can connect)	ABS	1	Option



- Parameter for setting Communication Response Time.
- The RP.TM is a Waiting Time to return upper device after processing received commands when controller received it from upper device.
- The setting of RP.TM is setting by 10 msec times. In case of RP.TM = 0, If the processing of commands is over, it returns response to upper device.

Symbol	Parameter	Setting range	Unit	Default	Display
RP.TM	Response Time	0 ~ 10 (x10ms)	ABS	0	Option

5.5. PLC Group(G.PLC)



- Group of PLC parameters
- PLC Group is displayed when selected PLC Protocol in Communication Protocol(Range of COM.P : P.OMR, P.MIT, P.LG, P.YKO, P.KEN and P.SIE)
- For more details, refer to Communication Manual.



- Parameter for setting Send Delay Time



- Parameter for setting Receive Delay Time

Symbol	Parameter	Setting range	Unit	Default	Display
SW.TM	Send Delay Time	0~50	ABS	10	COM.P = PLC
RW.TM	Receive Delay Time	500~1000	ABS	1000	



- Parameter for setting Max Number of Connections.

Symbol	Parameter	Setting range	Unit	Default	Display
MU.NO	Max Number Of Connections	1~31	ABS	1	COM.P = PLC

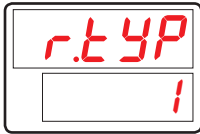

- Parameter for setting Type of Register.

Symbol	Parameter	Setting range	Unit	Default	Display
R.TYP	Register Type	0~3	ABS	0	COM.P = PLC



- Parameter for setting Start Address.

Symbol	Parameter	Setting range	Unit	Default	Display
S.ADR	Start Address	0~FFFF	ABS	03E8	COM.P = PLC



- Parameter for setting Data Map.

Symbol	Parameter	Setting range	Unit	Default	Display
MAP.S	Data Map Select	MAS.M, LOC.M	ABS	MAS.M	COM.P = PLC



■ Parameter for Setting Read Address.

Symbol	Parameter	Setting range	Unit	Default	Display
RO.01	Read Address 01	OFF, 0~200	ABS	151	COM.P = PLC
⋮	⋮	⋮	⋮	⋮	⋮
RO.13	Read Address 13	OFF, 0~200	ABS	OFF	COM.P = PLC



■ Parameter for setting Write Address.

Symbol	Parameter	Setting range	Unit	Default	Display
RW.01	Write Address 01	OFF, 0~150	ABS	1	COM.P = PLC
⋮	⋮	⋮	⋮	⋮	⋮
RW.15	Write Address 15	OFF, 0~150	ABS	OFF	COM.P = PLC

5.6. Now PLC Display Group(G.NPL)



- Group of PLC Display parameters
- PLC Display Group is displayed when selected PLC Protocol in Communication Progocol(Range of COM.P : P.OMR, P.MIT, P.LG, P.YKO, P.KEN and P.SIE)

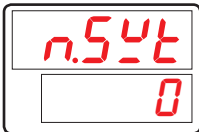

- Parameter for dispalying Now Send Delay Time

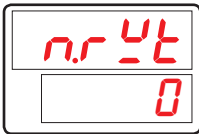

- Parameter for dispalying Now Receive Delay Time

Symbol	Parameter	Setting range	Unit	Default	Display
N.SWT	Now Send Delay Time	Reading area	ABS	0	COM.P = PLC
N.RWT	Now Receive Delay Time	Reading area	ABS	0	COM.P = PLC

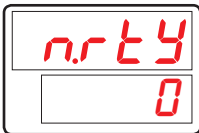

- Parameter for dispalying Now Register Type

Symbol	Parameter	Setting range	Unit	Default	Display
N.RTY	Now Register Type	Reading area	ABS	0	COM.P = PLC

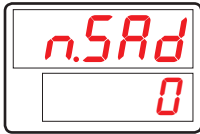

■ Parameter for dispalying Now Start Address

Symbol	Parameter	Setting range	Unit	Default	Display
N.SAD	Now Start Address	Reading area	ABS	0	COM.P = PLC



■ Parameter for dispalying Now Read Address

Symbol	Parameter	Setting range	Unit	Default	Display
N.O01	Now Read Address 01	Reading area	ABS	OFF	COM.P = PLC
⋮	⋮	⋮	⋮	⋮	⋮
N.O13	Now Read Address 13	Reading area	ABS	OFF	COM.P = PLC



■ Parameter for dispalying Now Write Address

Symbol	Parameter	Setting range	Unit	Default	Display
N.W01	Now Write Address 01	Reading area	ABS	OFF	COM.P = PLC
⋮	⋮	⋮	⋮	⋮	⋮
N.W15	Now Write Address 15	Reading area	ABS	OFF	COM.P = PLC

6. Display Error and Correction

[Table3] Display Error and Correction

Display Error	Error Contents	Correction
E.SYS	Eeprom, Data Loss	Ask Repair
E.RJC	RJC Sensor Failure	Ask Repair
Light off Decimal point of SP	Communication Failure	Comm Cable Check
S.OPN	Sensor Open	Sensor Check

Part **II** **Communication
Manual**



Table of Contents

1. Communication Overview	5
1.1. SS510E Communication	5
1.2. Communication Wiring	5
1.3. Communication Parameters	6
2. PC-LINK Communication	8
2.2. CHECK SUM	9
2.3. Type of Commands	10
2.3.1. RSD Command	11
2.3.2. RRD Command	12
2.3.3. WSD Command	13
2.3.4. WRD Command	14
2.3.5. STD Command	15
2.3.6. CLD Command	16
2.3.7. AMI Command	17
2.3.8. Error Code	18
3. MODBUS Communication	19
3.1. Composition of MODBUS Communication Command	19
3.2. Communication Function Code	20
3.2.1. Function Code - 03	21
3.2.2. Function Code - 06	22
3.2.3. Function Code - 08	23
3.2.4. Function Code - 16	24

Table of Contents

4. Programless Communication	25
4.1. Overview.....	25
4.2. Communication Setting	25
4.2.1. Protocol Setting	26
4.2.2. Baud rate, Parity bit, Stop Bit and Data Length Setting	26
4.2.3. Communication Address Setting	27
4.2.4. Send Delay Time, Receive Wait Time	27
4.2.5. Max Number of Connections	27
4.2.6. Register Type Setting	27
4.2.7. Start Address Setting	28
4.2.8. Data Map Setting	29
4.2.9. Memory Area Setting	31
4.3. Data Processing and Communication Status	34
4.3.1. Communication Procedure with PLC	34
4.4. Connection to OMRON PLC	36
4.4.1. Connection Diagram	36
4.4.2. Communication Wiring	36
4.4.3. SS510E Setting	37
4.4.4. PLC Setting	38
4.4.5. Data Monitoring and Setting	39
4.5. Connection to MITSUBISHI PLC	40
4.5.1. Connection Diagram	40
4.5.2. Communication Wiring	40
4.5.3. SS510E Setting	41
4.5.4. PLC Setting	41
4.5.5. Data Monitoring and Setting	42

Table of Contents

4.6. Connection to LG PLC	43
4.6.1. Connection Diagram	43
4.6.2. Communication Wiring	43
4.6.3. SS510E Setting	44
4.6.4. PLC Setting	44
4.6.5. Data Monitoring and Setting	45
4.7. Connection to YOKOGAWA PLC	46
4.7.1. Connection Diagram	46
4.7.2. Communication Wiring	46
4.7.3. SS510E Setting	47
4.7.4. PLC Setting	47
4.7.5. Data Monitoring and Setting	47
4.8. Connection to KEYENCE PLC	48
4.8.1. Connection Diagram	48
4.8.2. Communication Wiring	48
4.8.3. SS510E Setting	49
4.8.4. PLC Setting	49
4.8.5. Data Monitoring and Setting	49
4.9. Connection to SIEMENS PLC	51
4.9.1. Connection Diagram	51
4.9.2. Communication Wiring	51
4.9.3. SS510E Setting	52
4.9.4. PLC Setting	52
4.9.5. Data Monitoring and Setting	53

Table of Contents

5. Other Communication Function.....	54
5.1. Broadcast Mode	54
5.2. Service Port	55
6. Register Guide	56
6.1. PROCESS	57
6.2. FUNCTION GROUP	58
6.3. IN/OUT GROUP	58
6.4. COMM GROUP	59
6.5. PLC GROUP.....	59
6.9. NPL GROUP	60
6.9. D-Register Table	61

1. Communication Overview

1.1. SS510E Communication

- SS510E employs the half-duplex RS-485 communication interface which enables connections up to 31 devices.

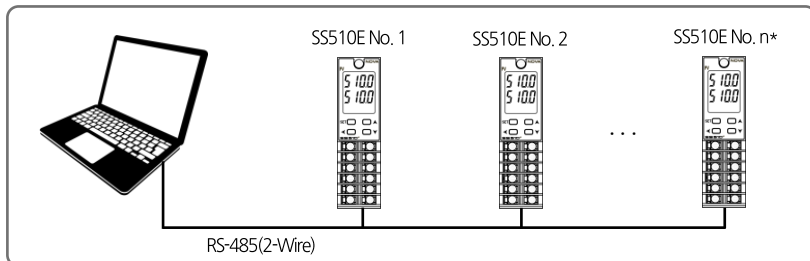

*MAX 31EA

1.2. Communication Wiring

- The RS-485 communication wiring between SS510E and devices are as follows.

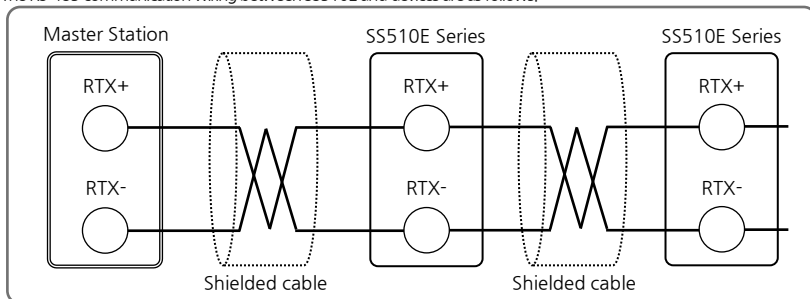

1.3. Communication Parameters

- Communication parameters are to set the communication conditions and their contents are as follows.

Communication Group Parameters

Parameter	Meaning	Set Value	Description	Initial Value
COM.P	Communication protocol	0	Standard protocol	
		1	Standard protocol + Check Sum	○
		2	MODBUS ASCII	
		3	MODBUS RTU	
		4	SYNC-Master	
		5	SYNC-Slave	
		6	Omron PLC	
		7	Mitsubishi PLC	
		8	LG PLC	
		9	Yokogawa PLC	
		10	Keyence PLC - Modbus slave mode	
11	Siemens PLC			
BAUD	Baud rate	0	9600bps	
		1	19200bps	
		2	38400bps	○
		3	57600bps	
		4	115200bps	
PRTY	Parity bit	NONE	No parity	○
		EVEN	Even parity	
		ODD	Odd parity	
S.BIT	Stop bit	1	1bit	○
		2	2bits	
D.LEN	Data length	7	7bits	
		8	8bits	
ADDR	Address	1~99	Address setting	1
RP.TM	Response time	1 ~ 10	Response time	0
R.BS	Remote SP	-	SP during synchronization	EUS(0.0%)



NOTE

- For the communication settings to apply, turn off and on the device.

PLC Group Parameters

Parameter	Meaning	Set Value	Description	Initial Value
SW.TM	Send delay time	0~50	Send delay [unit :ms]	10
RW.TM	Receive wait time	500~1000	Receive delay [unit :ms]	1000
M.Unit	Max number of units for connection	1~31	Max number of units for connection to programless communication	1
R.TYP	Register type	0~3	Send/receive data area	0
S.ADR	Start address	0~FFFF	Start address setting	3E8
MAP.S	Select data map	0, 1	'0' : Master, '1' : Local	0
RO.01~RO.13	Read area setting	1~200	Reading area address setting[13Ea]	-
RW.01~RW.15	Write area setting	1~150	Writing area address setting[15Ea]	-



NOTE

- PLC Group is displayed when PLC Protocol is selected in Communication Protocol (COM.P).

2. PC-LINK Communication

2.1. Composition of PC-LINK Communication Commands

- Basic communication commands that send data from communication units to SS510E are as follows.

PC-LINK Protocol

①	②	③	④	⑤	⑦	⑧
STX	SS510E address	Command	,	Data by command rule	CR	LF

PC-LINK+SUM Protocol

①	②	③	④	⑤	⑥	⑦	⑧
STX	SS510E address	Command	,	Data by command rule	SUM	CR	LF

① Communication command start text

Indicates start of communication command with STX, an ASCII code, with code value of 0x02

② SS510E address

Indicates unit address, the SS510E unit number for communication.

③ Command

Command for communication(Refer to 2.3. Type of Commands)

④ Separator

Indicates the separators that separate command and data using commas

⑤ Data

Indicates certain strings conforming to communication commands

⑥ SUM

Each of texts between STX and SUM is converted from the 1-byte (8-bit) code to 2-digit (hexadecimal) ASCII codes

⑦, ⑧ End-of-text character

An ASCII code that indicates the end of communication command and expressed as CR(0x0D) or LF(0x0A).

2.2. CHECK SUM

Example of SUM

When reading D-Register from NPV(D0001) to SP.SL(D0005)

Send : [STX]01RSD,05,0001[CR][LF]

Send(incl. CheckSum) : [STX]01RSD,05,0001C8[CR][LF]

- As shown below, each text from 01RSD,05,0001 converted into ASCII code and added as a hexadecimal number is 2C8.

The last two digits, C8, is used as CheckSum.

Text	0	1	R	S	D	,	0	5	,	0	0	0	1
Ascii	30	31	52	53	44	2C	30	35	2C	30	30	30	31



ASCII Control Code Chart

Prefix Suffix	0	1	2	3	4	5	6	7
0	NUL	DLE	SPACE	0	@	P	`	P
1	SOH	DC1	!	1	A	Q	a	q
2	STX	DC2	"	2	B	R	b	r
3	ETX	DC3	#	3	C	S	c	s
4	EOT	DC4	\$	4	D	T	d	t
5	ENQ	NAK	%	5	E	U	e	u
6	ACK	SYN	&	6	F	V	f	v
7	BEL	ETB	'	7	G	W	g	w
8	BS	CAN	(8	H	X	h	x
9	HT	EM)	9	I	Y	i	y
A	LF	SUB	*	:	J	Z	j	z
B	VT	ESC	+	;	K	[k	{
C	FF	FS	,	<	L	¥	l	
D	CR	GS	-	=	M]	m	}
E	SO	RS	.	>	N	^	n	~
F	SI	US	/	?	O	_	o	DEL

2.3. Type of Commands

- Communication commands can be categorized into Self-Information Command to read information of SS510E and Read / Write Command to read or write values in D-Register.

Self-Information Command

Command	Description
AMI	Displays SS510E model name and Version-Revision

Read/Write Command

Command	Description
RSD	Continuous reading of D-Register
RRD	Random reading of D-Register
WSD	Continuous writing of D-Register
WRD	Random writing of D-Register
STD	Random registration of D-Register
CLD	Call D-Register from STD

- Each command may read or write up to 64 D-Registers. In case of STD / CLD, registered items are initialized when power is turned off and register after turned on.

2.3.1. RSD Command

- A command used to read a series of data in D-Register.

Transmission Format

Bytes	1	2	3	1	2	1	4	2	1	1
Description	STX	SS510E address	RSD	,	Number	,	D-Reg.	SUM	CR	LF

Reception Format

Bytes	1	2	3	1	2	1	4	1	...
Description	STX	SS510E address	RSD	,	OK	,	Data - 1	,	...

1	4	2	1	1
,	Data - n	SUM	CR	LF

- Number : 1 ~ 64
- Data : Hexadecimal number without decimal point

Example

- When reading D-Register from PV.LO(D0022) PV.HI(D0023)

Send : [STX]01RSD,02,0001[CR][LF]

Send (incl. CheckSum) : [STX]01RSD,02,0001C6[CR][LF]

([STX] = 0x02, [CR] = 0x0d, [LF] = 0x0a)

- When received PV.LO(D0022) value is 30.0 and PV.HI(D0023) value is 50.0

Send : [STX]01RSD,OK,012C,01F4[CR][LF]

Send (incl. CheckSum) : [STX]01RSD,OK,012C,01F4C8[CR][LF]

- Process of converting the received PV value of hexadecimal number data to display

① Conversion to decimal number : 01F4(hexadecimal number) → 500(decimal number)

② Multiply 0.1 to converted value : 500 * 0.1 → 50.0

2.3.2. RRD Command

- A command used to read random data in D-Register.

Transmission Format

Bytes	1	2	3	1	2	1	4	1	...
Description	STX	SS510E address	RRD	,	Number	,	D-Reg. - 1	,	...

1	4	2	1	1
,	Data - n	SUM	CR	LF

Reception Format

Bytes	1	2	3	1	2	1	4	1	...
Description	STX	SS510E address	RRD	,	OK	,	Data - 1	,	...

1	4	2	1	1
,	Data - n	SUM	CR	LF

- Number : 1 ~ 64
- Data : Hexadecimal number without decimal point

Example

- When reading D-Register from NPV(D0001) to PV.LO(D0022)

Send : [STX]01RRD,02,0001,0022[CR][LF]

Send(incl. CheckSum) : [STX]01RRD,02,0001,0022B2[CR][LF]

- When received NPV(D0001) value is 50.0 and PV.LO(D0022) value is 30.0

Send : [STX]01RRD,OK,01F4,012C[CR][LF]

Send(incl. CheckSum) : [STX]01RRD,OK,01F4,012C18[CR][LF]

2.3.3. WSD Command

- A command used to write a series of data in D-Register.

Transmission Format

Bytes	1	2	3	1	2	1	4	1	4
Description	STX	SS510E address	WSD	,	Number	,	D-Reg.	,	Data - 1

1	...	1	4	2	1	1
,	...	,	Data - n	SUM	CR	LF

Reception Format

Bytes	1	2	3	1	2	2	1	1
Description	STX	SS510E address	WSD	,	Number	,	D-Reg.	,

- Number : 1 ~ 64
- Data : Hexadecimal number without decimal point

Example

- When writing data on IN.RH(D0603) and IN.RL(D0604) in input range

IN.RH setting: 1000 → To hexadecimal (0x03E8)

IN.RL setting: -100 → To hexadecimal (0xFF9C)

Send : [STX]01WSD,02,0603,03E8,FF9C[CR][LF]

Send(incl. CheckSum) : [STX]01WSD,02,0603,03E8,FF9C12[CR][LF]

2.3.4. WRD Command

- A command used to write random data in D-Register.

Transmission Format

Bytes	1	2	3	1	2	1	4	1	4
Description	STX	SS510E address	WRD	,	Number	,	D-Reg. - 1	,	Data - 1

1	...	1	4	1	4	2	1	1
,	...	,	D-Reg. - n	,	Data - n	SUM	CR	LF

Reception Format

Bytes	1	2	3	1	2	2	1	1
Description	STX	SS510E address	WRD	,	OK	SUM	CR	LF

- Number : 1 ~ 64
- Data : Hexadecimal number without decimal point

Example

- When writing data on IN.RH(D0603) and IN.RL(D0604) in input range

IN.RH setting : 1000 → Remove decimal place(1000)→ To hexadecimal (0x03E8)

IN.RL setting : -100 → Remove decimal place(-100)→ To hexadecimal (0xFF9C)

Send : [STX]01WRD,02,0603,03E8,0604,FF9C[CR][LF]

Send(incl. CheckSum) : [STX]01WRD,02,0603,03E8,0604,FF9C07[CR][LF]

2.3.5. STD Command

- A command to pre-register D-Register on SS510E.

Transmission Format

Bytes	1	2	3	1	2	1	4	1	4
Description	STX	SS510E address	STD	,	Number	,	D-Reg. - 1	,	D-Reg. - 2

1	...	1	4	1	4	2	1	1
,	...	,	D-Reg. - n	,	Data - n	SUM	CR	LF

Reception Format

Bytes	1	2	3	1	2	2	1	1
Description	STX	SS510E address	STD	,	OK	SUM	CR	LF

- Number : 1 ~ 64

Example

- When registering NPV(D0001) and, NSP(D0002)

Send : [STX]01STD,03,0001,0002[CR][LF]

Send(incl. CheckSum) : [STX]01STD,03,0001,0002B5[CR][LF]

2.3.6. CLD Command

- A command to read pre-registered D-Register by STD command from SS510E.

Transmission Format

Bytes	1	2	3	2	1	1
Description	STX	SS510E address	CLD	SUM	CR	LF

Reception Format

Bytes	1	2	3	1	2	1	4	1	4
Description	STX	SS510E address	CLD	,	OK	,	Data - 1	,	Data - 2

1	...	1	4	1	4	2	1	1
,	...	,	Data - (n-1)	,	Data - n	SUM	CR	LF

- Data : Hexadecimal number without decimal point

Example

Send : [STX]01CLD[CR][LF]
 Send(incl. CheckSum) : [STX]01CLD34[CR][LF]

2.3.7. AMI Command

- A command used to check information on SS510E.

Transmission Format

bytes	1	2	3	2	1	1
Description	STX	SS510E address	AMI	SUM	CR	LF

Reception Format

bytes	1	2	3	1	2	1
Description	STX	SS510E address	AMI	,	OK	,

9	1	7	2	1	1
Model name	SPACE	Version-Revision	SUM	CR	LF

Example

- When checking information on SS510E

```

Send           : [STX]01AMI[CR][LF]
Send(incl. CheckSum) : [STX]01AMI38[CR][LF]
Receive        : [STX]01AMI,OK SL54:4848[SP]V00-R00[CR][LF]
Receive(incl. CheckSu) : [STX]01AMI,OK SL54:4848[SP]V00-R0006[CR][LF]

```

2.3.8. Error Code

- The following is sent from SS510E when in error during communication.

Bytes	1	2	2	2	2	1	1
Description	STX	SS510E address	NG	Error code	SUM	CR	LF

Error Codes

Error Code	Description	Note
01	When designated a nonexistent command	
02	WHen designated a nonexistent D-Register	
04	Data setting error	Use of ineffective texts or data (Data employs hexadecimal numbers, 0~9 and A~F)
08	Wrong format	-Format different from designated command -Number different from designated number
11	Checksum error	
12	Monitoring command error	No designated monitoring command
00	Other errors	

3. MODBUS Communication

3.1. Composition of MODBUS Communication Command

- MODBUS communication comes in two modes, ASCII and RTU.

Data Format

Description	ASCII	RTU
Prefix	:(colon)	None
Suffix	[CR][LF]	None
Data Length	7-bit(fixed)	8-bit(fixed)
Data Format	ASCII	Binary
Error Detection	LRC (Longitudinal Redundancy Check)	CRC-16 (Cyclic Redundancy Check)
Data Interval	Less than 1s	Below 24-bit time

- Frame composition is as follows.

Modbus ASCII

Prefix	Communication Address	Function Code	Data	LRC Check	Suffix
1 character	2 characters	2 characters	N characters	2 characters	2 characters (CR+LF)

Modbus RTU

Prefix	Communication Address	Function Code	Data	CRC Check	Suffix
None	8-bit	8-bit	N * 8-bit	16-bit	None

N : Number of hexadecimal data

3.2. Communication Function Code

- MODBUS Communication Function Codes are composed of function codes to read and write D-Register and Loop-Back detection function codes.

Function Code	Description
03	Continuous reading of D-Register
06	Writing of single D-Register
08	Diagnostics(Loop-Back Test)
16	Continuous writing of D-Register



NOTE

When using MODBUS protocol, because D-Register starts from 0, 1 must be subtracted from the numbers in D-Register table.

3.2.1. Function Code - 03

- Function Code – 03 can continuously read up to 64 items in D-Register.

Transmission Format

Description	ASCII	RTU
Communication Prefix	:(Colon)	None
Communication Address	2 characters	8-bit
Function Code - 03	2 characters	8-bit
D-Register Hi	2 characters	8-bit
D-Register Lo	2 characters	8-bit
Number to Read Hi	2 characters	8-bit
Number to Read Lo	2 characters	8-bit
Error Detection	2 characters	16-bit
Communication Suffix	2 characters(CR+LF)	None

Example

- When reading D-Register from PV.LO(D0022) to PV.HI(D0023)

MODBUS ASCII : :010300150002FA[CR][LF]

MODBUS RTU : 010300150002C40B



Apply numbers from D-Register table subtracted by 1.

NOTE

Reception Format

Description	ASCII	RTU
Communication Prefix	:(Colon)	None
Communication Address	2 characters	8-bit
Function Code - 03	2 characters	8-bit
Data Bytes	2 characters	8-bit
Data - 1 Hi	2 characters	8-bit
Data - 1 Lo	2 characters	8-bit
...
Data - n Hi	2 characters	8-bit
Data - n Lo	2 characters	8-bit
Error Detection	2 characters	16-bit
Communication Suffix	2 characters(CR+LF)	None

Example

- When the received NPV(D0001) value is 25.0 and NSP(D0002) value is 100.0

MODBUS ASCII : :01030400FA03E813[CR][LF]

MODBUS RTU : 01030400FA03E8DABC

3.2.2. Function Code - 06

- Function Code - 06 allows the sure to enter a single D-Register entry.

Transmission Format

Description	ASCII	RTU
Communication Prefix	:(Colon)	None
Communication Address	2 characters	8-bit
Function Code - 06	2 characters	8-bit
D-Register Hi	2 characters	8-bit
D-Register Lo	2 characters	8-bit
Write Data Hi	2 characters	8-bit
Write Data Lo	2 characters	8-bit
Error Detection	2 characters	16-bit
Communication Suffix	2 characters(CR+LF)	None

Example

- When setting 1000 to IN.RH(D0603) for operation

MODBUS ASCII : :0106025B03E8B1[CR][LF]

MODBUS RTU : 0106025B03E8F91F



Apply numbers from D-Register table subtracted by 1.

NOTE

Reception Format

Description	ASCII	RTU
Communication Prefix	:(Colon)	None
Communication Address	2 characters	8-bit
Function Code - 06	2 characters	8-bit
D-Register Hi	2 characters	8-bit
D-Register Lo	2 characters	8-bit
Write Data Hi	2 characters	8-bit
Write Data Lo	2 characters	8-bit
Error Detection	2 characters	16-bit
Communication Suffix	2 characters(CR+LF)	None

Example

- Under normal setting, the user will receive as the following.

MODBUS ASCII : :0106025B03E8B1[CR][LF]

MODBUS RTU : 0106025B03E8F91F

3.2.3. Function Code - 08

- Function Code - 08 is used for self-diagnosis.

Transmission Format

Description	ASCII	RTU
Communication Prefix	:(Colon)	None
Communication Address	2 characters	8-bit
Function Code - 08	2 characters	8-bit
Diagnosis Code Hi	2 characters	8-bit
Diagnosis Code Lo	2 characters	8-bit
Data Hi	2 characters	8-bit
Data Lo	2 characters	8-bit
Error Detection	2 characters	16-bit
Communication Suffix	2 characters(CR+LF)	None

Example

- When sent the following frame for self-diagnosis
 MODBUS ASCII : :010800000002F5[CR][LF]
 MODBUS RTU : 01080000000261CA

Reception Format

Description	ASCII	RTU
Communication Prefix	:(Colon)	None
Communication Address	2 characters	8-bit
Function Code - 08	2 characters	8-bit
Diagnosis Code Hi	2 characters	8-bit
Diagnosis Code Lo	2 characters	8-bit
Data Hi	2 characters	8-bit
Data Lo	2 characters	8-bit
Error Detection	2 characters	16-bit
Communication Suffix	2 characters(CR+LF)	None

Example

- Under normal setting, the user will receive as the following.
 MODBUS ASCII : :010800000002F5[CR][LF]
 MODBUS RTU : 01080000000261CA

3.2.4. Function Code - 16

- Function Code - 16 allows the user to enter up to 64 items in a series of D-Register.

Transmission Format

Description	ASCII	RTU
Communication Prefix	:(Colon)	None
Communication Address	2 characters	8-bit
Function Code - 16	2 characters	8-bit
D-Register Hi	2 characters	8-bit
D-Register Lo	2 characters	8-bit
Number to Write Hi	2 characters	8-bit
Number to Write Lo	2 characters	8-bit
Data Bytes	2 characters	8-bit
Data - 1 Hi	2 characters	8-bit
Data - 1 Lo	2 characters	8-bit
...
Data - n Hi	2 characters	8-bit
Data - n Lo	2 characters	8-bit
Error Detection	2 characters(CR+LF)	None
Communication Suffix	2 characters	16-bit

Example

- When setting 1000 and -100 to IN.RH(D0603) and IN.RL(D0604), respectively to change setting
 MODBUS ASCII : :0110025B00020403E8FF9C06[CR][LF]
 MODBUS RTU : 0110025B000204000100326FA9

Reception Format

Description	ASCII	RTU
Communication Prefix	:(Colon)	None
Communication Address	2 characters	8-bit
Function Code - 16	2 characters	8-bit
D-Register Hi	2 characters	8-bit
D-Register Lo	2 characters	8-bit
Number to Write Hi	2 characters	8-bit
Number to Write Lo	2 characters	8-bit
Error Detection	2 characters	16-bit
Communication Suffix	2 characters(CR+LF)	None

Example

- Under normal setting, the user will receive as the following.
 MODBUS ASCII : :0110025B000290[CR][LF]
 MODBUS RTU : 0110025B000231A3

4. Programless Communication

4.1. Overview

- SS510E can regulate the controller through parameter read/write function without protocol PLC and programs. Also, the Slave Module can receive information from Master Module without additional setting and send them to PLC.

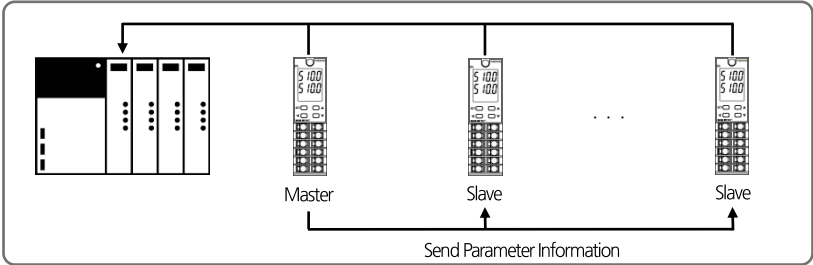

4.2. Communication Setting

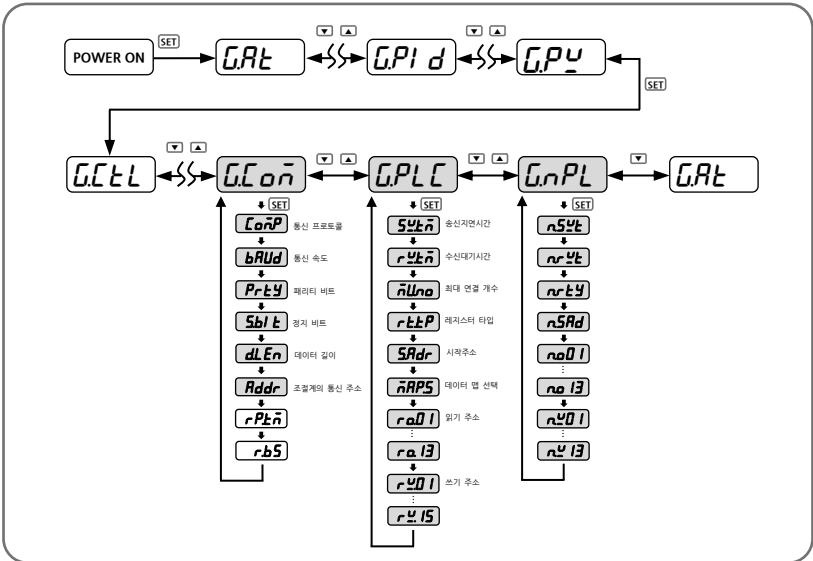

4.2.1. Protocol Setting

- Built-in PLC protocols in SS510E are OMRON, MITSUBISHI, LG, YOKOGAWA, KEYENCE and SIEMENS. The PLC can control and communicate without ladder programs.

Group	Parameter	Set Value	Description
G.Coñ	CoñP	P.oñr	OMRON SYSMAC Protocol
		P.ñi t	MITSUBISHI MELSEC Q/QnACPU Protocol
		P. LG	LG MASTER-K(XGK, XGB, XBC) Protocol
		P.YEo	YOKOGAWA FA-M3 Protocol
		P.YEñ	KEYENCE MODBUS RTU Protocol
		P.SI E	SIEMENS MODBUS RTU Protocol

4.2.2. Baud rate, Parity bit, Stop Bit and Data Length Setting

- For setting speed, parity bit, stop bit and data length for communication.

Group	Parameter	Set Value	Description	
G.Coñ	bAUd	9600	9600	Set communication speed
		19200	19200	
		384E	38400(Initial Value)	
		576E	57600	
		1152E	115200	
	Prty	nonE	NONE(Initial Value)	Set communication parity
		EYEñ	EVEN	
		odd	ODD	
	Sbit	1, 2	Set communication stop bit (Initial Value : 1)	
	dLEñ	7, 8	Set communication data length (Initial Value : 8)	

4.2.3. Communication Address Setting

- SS510E Series can set up to addresses 1 to 99, where the first, 1, is Master. Master unit is essential for PLC communication.

Group	Parameter	Set Value	Description
<i>GCon</i>	<i>Addr</i>	<i>1~99</i>	Set communication address(Initial Value : 1)

4.2.4. Send Delay Time, Receive Wait Time

- Sets send delay time and receive wait time. Send delay time denotes delay time required for SS510E to send data and receive wait time denotes waiting time for a response from PLC.

Group	Parameter	Set Value	Description
<i>GPLC</i>	<i>Sytn</i>	<i>0~50</i>	Send delay time (Initial Value : 10ms)
	<i>rytn</i>	<i>500~1000</i>	Receive wait time (Initial Value : 1000ms)

4.2.5. Max Number of Connections

- Max number of connections indicate number of SP590E connected to PLC - the value must be set according to number of modules.

Group	Parameter	Set Value	Description
<i>GPLC</i>	<i>nUno</i>	<i>1~31</i>	Set max connections (Initial Value : 1)

4.2.6. Register Type Setting

- Sets register type. This parameter sets send / receive memory area of PLC.

Group	Parameter	Set Value	Description	
			MITSUBISHI PLC	Other PLC
<i>GPLC</i>	<i>rtyp</i>	<i>0</i>	D Register	D Register (fixed)
		<i>1</i>	W Register	
		<i>2</i>	R Register	
		<i>3</i>	ZR Register	

4.2.7. Start Address Setting

- Sets start address of PLC memory area. 30 words are uniformly allocated to PLC area according start address setting.

Group	Parameter	Set Value	Description
<i>GP.LC</i>	<i>SAdr</i>	<i>0~FFFF</i>	Start Address Setting (Initial Value :03E8[1000])

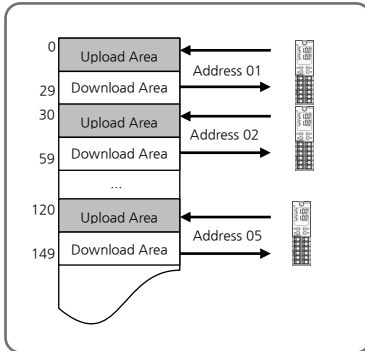

When Start Address of Product is 0

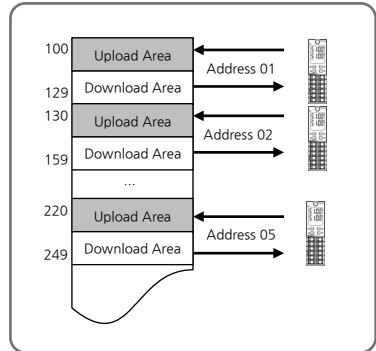

When Start Address of Product is 100[0064]



NOTE

- S5S10E(Slave) Start Address : Start Address (Master) + (SS510E Address - 1) * 30

4.2.8. Data Map Setting

- Data Map Setting is composed of 'MASTER' setting that uses information by copying them from a master module and copying into a slave module, and 'LOCAL' setting that uses information in SSS10E.

Group	Parameter	Set Value	Description
G.PLC	nAPS	nASn	MASTER Setting (Initial Value)
		LoLn	LOCAL Setting

- If Data Map Setting is MASTER, the slave module receives send delay time, receive wait time, register type, start address and data map information from master module and enter the data into PLC memory area.
- Parameter information from MASTER can be checked in G.NPL Group.

Group	Parameter	Set Value	Description
G.NPL	nSyt	-	Send delay time information
	nrYt	-	Receive wait time information
	nrty	-	Register type information
	nSAd	-	Start address information
	n0.01 ~ n0.13	-	Read area address information [13EA]
	nY.01 ~ nY.15	-	Write area address information[15EA]



- G.NPL Group is a read-only parameter.

Master Setting

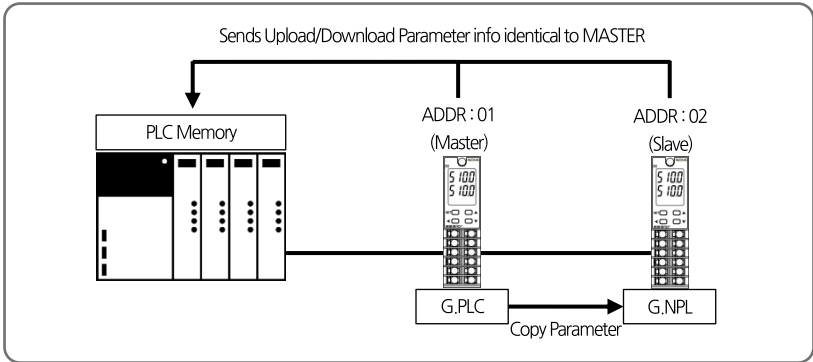

- Master Setting must be composed of the same product group (SP, ST, SD and SL) for normal operation.

LOCAL Setting

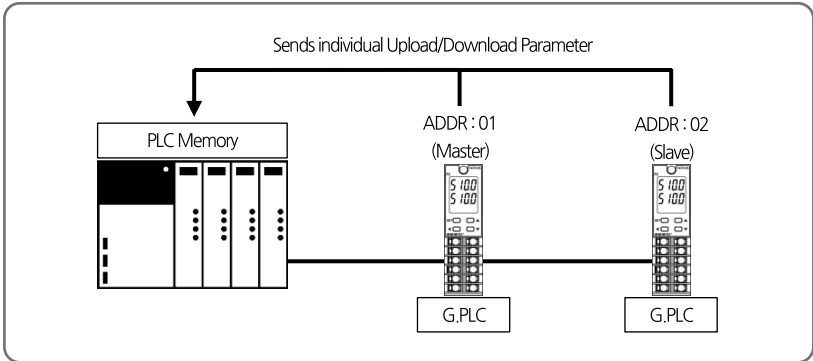

4.2.9. Memory Area Setting

- Sets 13 read-only parameters and 15 read/write parameters to be sent to PLC memory area.
- Users can built a data map by referring to the upload/download setting table and send data map information to PLC memory area.

Group	Parameter	Set Value	Description
<i>G.PLC</i>	<i>ro.01</i> ~ <i>ro.13</i>	<i>1~200</i>	Set read area address [13EA]
	<i>rw.01</i> ~ <i>rw.15</i>	<i>1~150</i>	Set write area address [15EA]

Example

- Setting 161[PROC.TIME] of RO.01 in 151[NPV] will send PROC.TIME value to RO.01 area in PLC.

SS510E Data Map Initial Setting Chart

Parameter	Setting Range	Initial Value	
RO.01	OFF[Not Set], 1 ~ 200	151	NPV
RO.02	OFF[Not Set], 1 ~ 200	OFF	-
RO.03	OFF[Not Set], 1 ~ 200	OFF	-
RO.04	OFF[Not Set], 1 ~ 200	OFF	-
RO.05	OFF[Not Set], 1 ~ 200	OFF	-
RO.06	OFF[Not Set], 1 ~ 200	OFF	-
RO.07	OFF[Not Set], 1 ~ 200	OFF	-
RO.08	OFF[Not Set], 1 ~ 200	OFF	-
RO.09	OFF[Not Set], 1 ~ 200	OFF	-
RO.10	OFF[Not Set], 1 ~ 200	OFF	-
RO.11	OFF[Not Set], 1 ~ 200	OFF	-
RO.12	OFF[Not Set], 1 ~ 200	OFF	-
RO.13	OFF[Not Set], 1 ~ 200	OFF	-
RW.01	OFF[Not Set], 1 ~ 150	OFF	-
RW.02	OFF[Not Set], 1 ~ 150	OFF	-
RW.03	OFF[Not Set], 1 ~ 150	OFF	-
RW.04	OFF[Not Set], 1 ~ 150	OFF	-
RW.05	OFF[Not Set], 1 ~ 150	OFF	-
RW.06	OFF[Not Set], 1 ~ 150	OFF	-
RW.07	OFF[Not Set], 1 ~ 150	65	ALBS
RW.08	OFF[Not Set], 1 ~ 150	OFF	-
RW.09	OFF[Not Set], 1 ~ 150	OFF	-
RW.10	OFF[Not Set], 1 ~ 150	OFF	-
RW.11	OFF[Not Set], 1 ~ 150	OFF	-
RW.12	OFF[Not Set], 1 ~ 150	OFF	-
RW.13	OFF[Not Set], 1 ~ 150	OFF	-
RW.14	OFF[Not Set], 1 ~ 150	OFF	-
RW.15	OFF[Not Set], 1 ~ 150	OFF	-

UPLOAD/DOWNLOAD Setting Table

	Set Value	Parameter	
U/D	65	ALBS	D0621
U	151	NPV	D0001

PLC Register Table

	SS510E Address	Parameter	
BASIC	Start Address + (SS510E ADDRESS - 1) * 30 + 0	Trigger	READ/WRITE
	Start Address + (SS510E ADDRESS - 1) * 30 + 0	Communication Status Flag (STS.F)	READ
R E A D	Start Address + (SS510E ADDRESS - 1) * 30 + 2	RO.01	READ
	Start Address + (SS510E ADDRESS - 1) * 30 + 3	RO.02	READ
	Start Address + (SS510E ADDRESS - 1) * 30 + 4	RO.03	READ
	Start Address + (SS510E ADDRESS - 1) * 30 + 5	RO.04	READ
	Start Address + (SS510E ADDRESS - 1) * 30 + 6	RO.05	READ
	Start Address + (SS510E ADDRESS - 1) * 30 + 7	RO.06	READ
	Start Address + (SS510E ADDRESS - 1) * 30 + 8	RO.07	READ
	Start Address + (SS510E ADDRESS - 1) * 30 + 9	RO.08	READ
	Start Address + (SS510E ADDRESS - 1) * 30 + 10	RO.09	READ
	Start Address + (SS510E ADDRESS - 1) * 30 + 11	RO.10	READ
	Start Address + (SS510E ADDRESS - 1) * 30 + 12	RO.11	READ
	Start Address + (SS510E ADDRESS - 1) * 30 + 13	RO.12	READ
	Start Address + (SS510E ADDRESS - 1) * 30 + 14	RO.13	READ
R E A D & W R I T E	Start Address + (SS510E ADDRESS - 1) * 30 + 15	RW.01	READ/WRITE
	Start Address + (SS510E ADDRESS - 1) * 30 + 16	RW.02	READ/WRITE
	Start Address + (SS510E ADDRESS - 1) * 30 + 17	RW.03	READ/WRITE
	Start Address + (SS510E ADDRESS - 1) * 30 + 18	RW.04	READ/WRITE
	Start Address + (SS510E ADDRESS - 1) * 30 + 19	RW.05	READ/WRITE
	Start Address + (SS510E ADDRESS - 1) * 30 + 20	RW.06	READ/WRITE
	Start Address + (SS510E ADDRESS - 1) * 30 + 21	RW.07	READ/WRITE
	Start Address + (SS510E ADDRESS - 1) * 30 + 22	RW.08	READ/WRITE
	Start Address + (SS510E ADDRESS - 1) * 30 + 23	RW.09	READ/WRITE
	Start Address + (SS510E ADDRESS - 1) * 30 + 24	RW.10	READ/WRITE
	Start Address + (SS510E ADDRESS - 1) * 30 + 25	RW.11	READ/WRITE
	Start Address + (SS510E ADDRESS - 1) * 30 + 26	RW.12	READ/WRITE
	Start Address + (SS510E ADDRESS - 1) * 30 + 27	RW.13	READ/WRITE
	Start Address + (SS510E ADDRESS - 1) * 30 + 28	RW.14	READ/WRITE
	Start Address + (SS510E ADDRESS - 1) * 30 + 29	RW.15	READ/WRITE

4.3. Data Processing and Communication Status

- Able to check communication status with PLC using parameters in BASIC area and read / write data using a trigger.

Parameter	Set Value	Description
Trigger (TRG)	0	Monitor : Reads READ area data
	1	Setting : Writes data on S5510E
	2	Set Value Monitor : Reads READ&WRITE area data
Status Flag (STS,F)	0, 1	Displays communication status

4.3.1. Communication Procedure with PLC

- When the trigger is 0

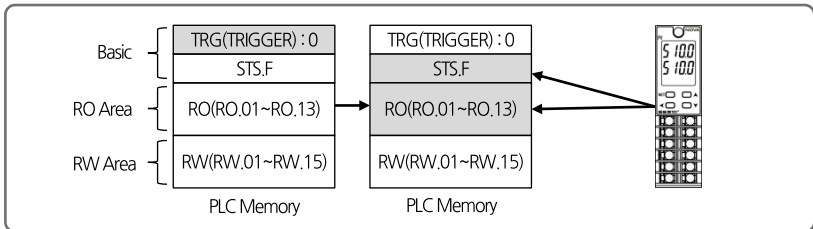

- ① When the trigger is set at 0, it writes READ area (RO.01~RO.13) data in NOVA500E to PLC and reverses communication status flag (0->1, 1->0) and write to PLC.

- When the trigger is 1

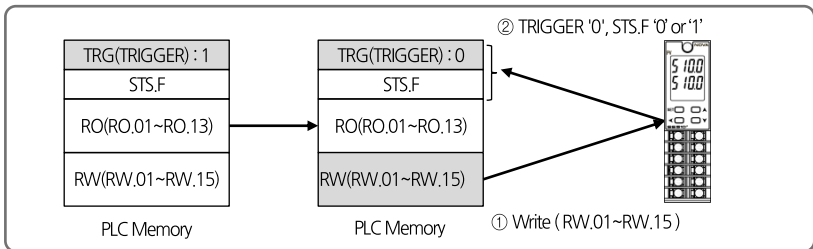

- ① When the trigger is set at 1 in PLC, it writes data in READ&WRITE area (RW.01~RW.15) to S5510E.
- ② Sets triggers from 1 to 0 and reverses communication flag value (0->1, 1->0) and write in PLC.



- It is important to check whether or not the READ & WRITE area is synchronized prior to writing set values as unsynchronized S5510E and PLC set values may influence current S5510E set values.

■ When trigger is 2

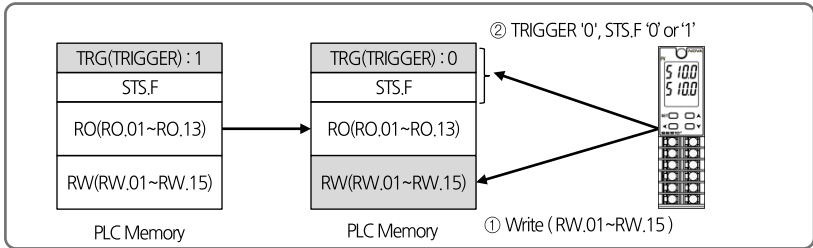

① When the trigger is set at 2 in PLC, it writes data in READ&WRITE area (RW.01~RW.15) to S510E.

② Sets triggers from 2 to 0 and reverses communication flag value (0->1, 1->0) and write in PLC.



- Because READ&WRITE area is prior to synchronization at first communication with PLC, the user must carry out synchronization after setting trigger to 2 (Set value monitor).

4.4. Connection to OMRON PLC

4.4.1. Connection Diagram

- Next is an example of composition for programless communication with OMRON SYSMAC CJ1M CPU11.

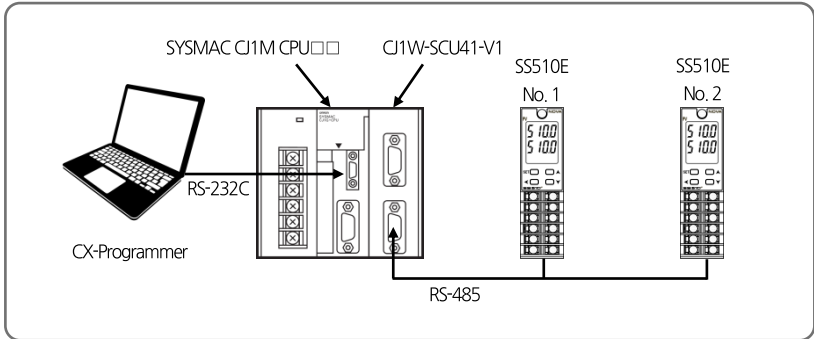

4.4.2. Communication Wiring

- Wire SS510E and CJ1W-SCU41-V1 communication modules as below.

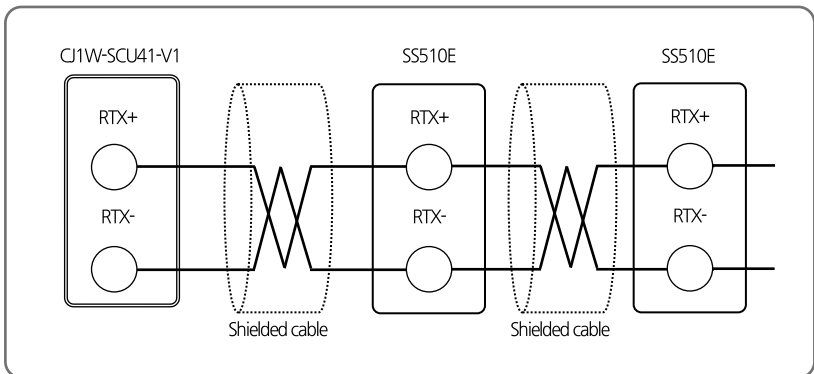

4.4.3. SS510E Setting

- Sets communication parameters pertinent to SS510E Series and PLC for programless communication.
- Refer to 4. Communication Setting and set as below.

1) **Sets protocol and communication address in G.COM. Employ default settings for remaining parameters.**

Set communication protocol according to PLC type by referring to 4.2.1 Protocol Setting. For communication address setting, set address of MASTER module to 1 and 2 for remaining module addresses.

Communication protocol setting(COM.P) : Set according to PLC type

- ▶ Transmission speed (BAUD) : 38400bps
- ▶ Parity bit(PRTY) : None
- ▶ Stop bit(S.BIT) : 1
- ▶ Data length(D.LEN) : 8
- ▶ Communication address(ADDR) : 1

2) **Set max number of connections in G,PLC. Employ default settings for remaining parameters.**

Set max number of connections as the last communication address to the current SS510E Series and set data map setting as 'MASTER'.

- ▶ Send delay time(SW.TM) : 10(msec)
- ▶ Receive wait time (RW.TM) : 1000(msec)
- ▶ Max number of connection(MU.NO) : Number of connections by SS510E Series
- ▶ Register type(R.TYP) : 0
- ▶ Start address setting(S.ADR) : 1000
- ▶ Data map setting(MAP.S) : MASTER

4.4.4. PLC Setting

■ Connecting to PLC

- ① Connect PC and OMRON PLC and execute CX-Programmer
- ② From menu, select 'PLC ->Auto Online'
- ③ Upload after a normal connection to PLC

■ Communication setting of module

- ① Select 'PLC -> Operating Mode -> Program' from menu
- ② Double click on 'I/O Table' on the 'Project' window
- ③ Double click on Main Rack on the 'PLC IO Table' window
- ④ Right click on Serial Communications Unit and select Software Switches
- ⑤ Make communication setting from relevant port on Serial CommS Unit Software Switches window. (Refer to SS510E Setting)

Item		Set Value	
Communication Settings	Baud	38400	SS510E Default Value
	Format	1, 8, 1, N	SS510E Default Value
	Mode	Default(Host Link)	SS510E Default Value

- ⑥ Upon completion, select 'Options ->Transfer to PLC' on the Serial CommS Unit Software Switches window to save.

4.4.5. Data Monitoring and Setting

■ SS510E Data Monitoring

- ① Access PLC using CX-Programmer
- ② Double click on 'Memory' on 'Project' window
- ③ Select 'D' on 'PLC Memory' window and click on 'Monitor'
- ④ Check up to 30 words of data per product in relevant register area

- Based upon default value of data map setting, the register area data are as follows.

ADDRESS.1	ADDRESS.2	ADDRESS.3	Parameter	Value
D1000	D1030	D1060	Trigger	0
D1001	D1031	D1061	Communication status flag	1, 0 repeat
D1002	D1032	D1062	NPV	-
D1021	D1051	D1081	ALBS	-

R0 Area , RW Area

■ SS510E Set Value Monitoring

- ① Enter '2 (Read Set Value)' in the register relevant to Trigger Area (D1000)
- ② After the trigger is changed to '2' and data writing is complete in RW area, the trigger is changed to '0' and the process is complete
- ③ Check the values in the uploaded RW Area(D1015-D1029)

■ Changing ALBS through Writing SS510E Set Value

- ① Enter set value '1' in the register relevant to ALBS(D1021)
- ③ Enter '1 (Read Set Value)' in the register relevant to Trigger (D1000)
- ⑤ After the trigger is changed to '1' and writing from PLC to SS510E is complete, the trigger is changed to '0' and the process is complete.

4.5. Connection to MITSUBISHI PLC

4.5.1. Connection Diagram

- Next is an example of composition for programless communication with MITSUBISHI Melec Q Series.

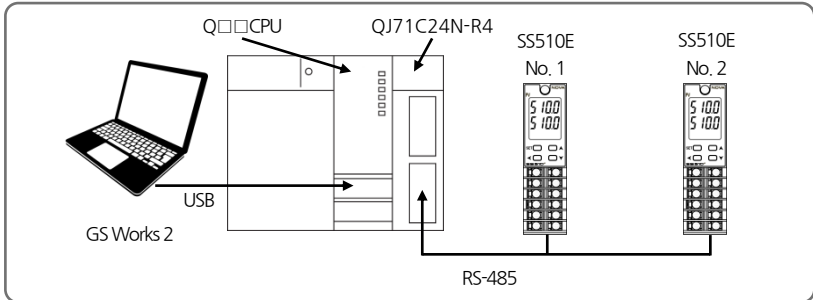

4.5.2. Communication Wiring

- Wire SS510E and QJ71C24N-R4 as below.

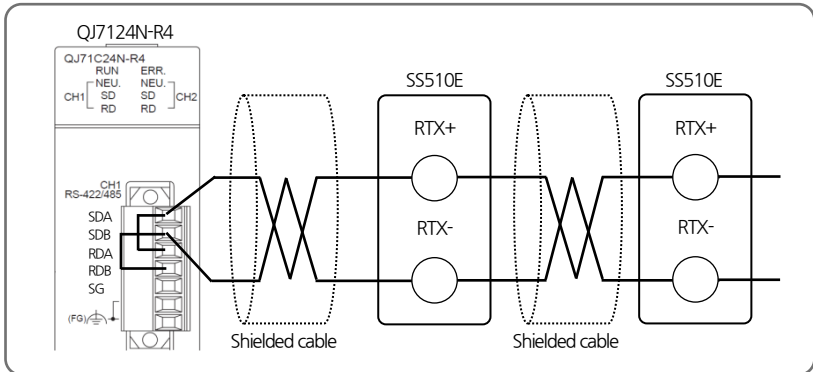

4.5.3. SS510E Setting

- Refer to 4.4.3 SS510E Setting

4.5.4. PLC Setting

■ Connection to PLC

- ① Connect PC and Melsec Q Series CPU and execute GX-Works2
- ② Select 'Online -> Read from PLC' from menu
- ③ Select QCPU(Q mode) and click on 'OK'
- ④ When 'Online Data Operation' window opens, click on 'Execute' to read data
- ⑤ After upload is complete, close the window

■ Communication setting of module

- ① Double click on 'Intelligent Function Module' on 'Navigation' window
- ② Double click on 'QJ71C24N-R4' module and then 'Switch Setting'
- ③ Set communication option parameters of channels connected to SS510E as shown below. (Refer to SS510E SETTING)

Item		Set Value	
Transmission setting	Operation setting	Independent	
	Data Bit	8	SS510E Default Value
	Parity Bit	None	SS510E Default Value
	Even/Odd Parity	None	
	Stop Bit	1	SS510E Default Value
	Sum check code	Exist	-
	Online Change	Enable	-
	Setting modifications	Enable	-
Communication rate setting		38400bps	SS510E Default Value
Communication protocol setting		MC protocol(format 4)	-
Station number setting(0-31)		0	

- ④ After setting is complete, select 'Online -> Write to PLC' from menu
- ⑤ When 'Online Data Operation' window opens, select 'Intelligent Function Module' and check relevant items
- ⑥ Complete setting by clicking on 'Execute'

4.5.5. Data Monitoring and Setting

■ SS510E Data Monitoring

- ① Access PLC using GS Works 2
- ② Select 'Online -> Monitor -> Device Buffer Memory Batch' from menu
- ③ Enter 'D1000' in 'Device Name' on 'Device Buffer Memory Batch' window
- ④ Check up to 30 words of data per product in relevant register area

- Based upon default value of data map setting, the register area data are as follows.

ADDRESS.1	ADDRESS.2	ADDRESS.3	Parameter	Value
D1000	D1030	D1060	Trigger	0
D1001	D1031	D1061	Communication status flag	1, 0 repeat
D1002	D1032	D1062	NPV	-
D1021	D1051	D1081	ALBS	-

R0 영역 , RW 영역

■ SS510E Set Value Monitoring

- ① Enter '2 (Read Set Value)' in the register relevant to Trigger Area (D1000)
- ② After the trigger is changed to '2' and data writing is complete in RW area, the trigger is changed to '0' and the process is complete
- ③ Check the values in the uploaded RW Area(D1015~D1029)

■ Changing ALBS through Writing SS510E Set Value

- ① Enter set value '1' in the register relevant to ALBS(D1021)
- ③ Enter '1 (Read Set Value)' in the register relevant to Trigger (D1000)
- ⑤ After the trigger is changed to '1' and writing from PLC to SS510E is complete, the trigger is changed to '0' and the process is complete.

4.6. Connection to LG PLC

4.6.1. Connection Diagram

- Next is an example of composition for programless communication with LS PLC(XBM-DR16S).

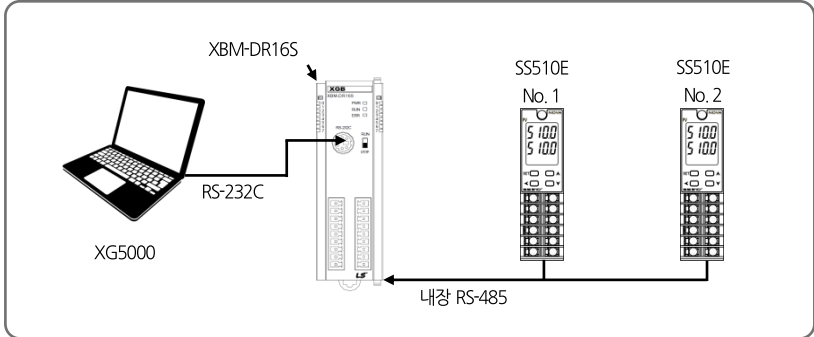

4.6.2. Communication Wiring

- Wire SS510E and XBM-DR16S communication modules as below.

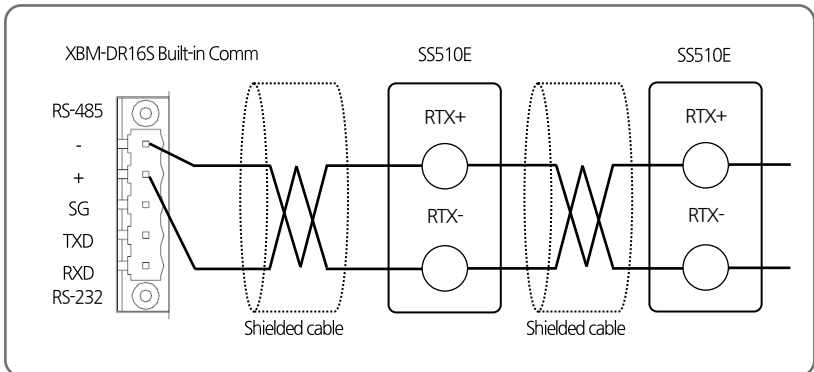

4.6.3. SS510E Setting

- Refer to 4.4.3 SS510E Setting

4.6.4. PLC Setting

■ Connection to PLC

- ① Connect PC and LS PLC and execute XG5000
- ② Select 'Project -> Open from PLC' from menu
- ③ Set parameters according to connection method and click on 'Access'

■ Communication setting of module

- ① From 'XG5000 Project' window, select 'Network Composition -> Basic Network -> New PLC [BOS0 Built-in Cnet]'
- ② Set relevant channels in Basic Setting window as below

Item		Set Value	
Access Setting	Transmission speed	38400	SS510E Default Value
	Data bit	8	SS510E Default Value
	Stop bit	1	SS510E Default Value
	Parity bit	NONE	SS510E Default Value

- ④ After setting is complete, select 'Online -> Write to PLC' from menu
- ⑤ Complete setting by clicking on 'Confirm' on 'Write' window and changing PLC setting to Writing.

4.6.5. Data Monitoring and Setting

■ SS510E Data Monitoring

- ① Access PLC by using GX5000
- ② Select 'Monitor -> Device Monitor' from menu
- ④ Select 'D' area on 'Device Monitor' window and check relevant register

- Based upon default value of data map setting, the register area data are as follows.

ADDRESS.1	ADDRESS.2	ADDRESS.3	Parameter	Value
D1000	D1030	D1060	Trigger	0
D1001	D1031	D1061	Communication status flag	1, 0 repeat
D1002	D1032	D1062	NPV	-
D1021	D1051	D1081	ALBS	-

R0 Area , RW Area

■ SS510E Set Value Monitoring

- ① Enter '2 (Read Set Value)' in the register relevant to Trigger Area (D1000)
- ② After the trigger is changed to '2' and data writing is complete in RW area, the trigger is changed to '0' and the process is complete
- ③ Check the values in the uploaded RW Area(D1015~D1029)

■ Changing ALBS through Writing SS510E Set Value

- ① Enter set value '1' in the register relevant to ALBS(D1021)
- ③ Enter '1 (Read Set Value)' in the register relevant to Trigger (D1000)
- ⑤ After the trigger is changed to '1' and writing from PLC to SS510E is complete, the trigger is changed to '0' and the process is complete.

4.7. Connection to YOKOGAWA PLC

4.7.1. Connection Diagram

- Next is an example of composition for programless communication with YOKOGAWA PLC.

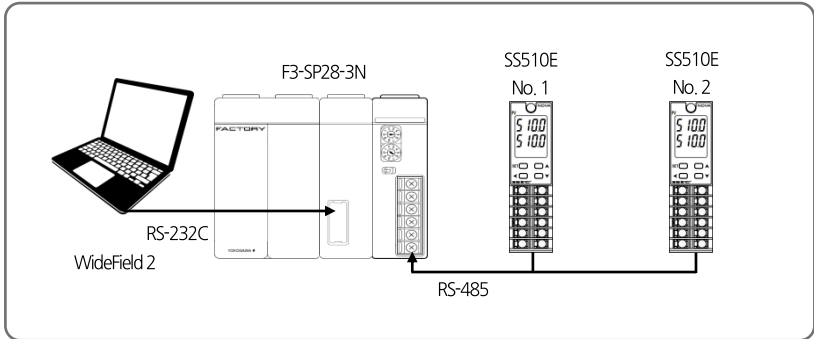

4.7.2. Communication Wiring

- Wire SS510E and LC11-2F as below.

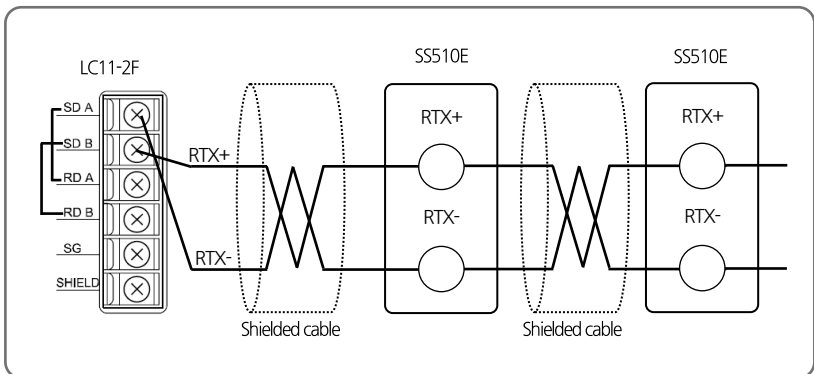

4.7.3. SS510E Setting

- Refer to 4.4.3 SS510E Setting



Data area of YOKOGAWA PLC starts at '1'. Make sure not to set start address of SS510E at '0'.

4.7.4. PLC Setting

- Setting communication module

Open right cover of LC11-2F and set up as below.

Item		Set Value	
SW1		38.4kbps(9)	SS510E Default Value
SW2	Character Length	8bit(ON)	-
	Check Sum	YES(ON)	-
	Terminator	YES(ON)	-

4.7.5. Data Monitoring and Setting

- SS510E Data Monitoring

- ① Access PLC using WideField2
- ② Select 'Online ->Device Monitor -> D Data Register' and check relevant register

- Based upon default value of data map setting, the register area data are as follows.

ADDRESS.1	ADDRESS.2	ADDRESS.3	Parameter	Value
D1000	D1030	D1060	Trigger	0
D1001	D1031	D1061	Communication status flag	1, 0 repeat
D1002	D1032	D1062	NPV	-
D1021	D1051	D1081	ALBS	-

RO Area , RW Area

- SS510E Set Value Monitoring

- ① Enter '2 (Read Set Value)' in the register relevant to Trigger Area (D1000)
- ② After the trigger is changed to '2' and data writing is complete in RW area, the trigger is changed to '0' and the process is complete
- ③ Check the values in the uploaded RW Area(D1015~D1029)

- Changing ALBS through Writing SS510E Set Value

- ① Enter set value '1' in the register relevant to ALBS(D1021)
- ③ Enter '1 (Read Set Value)' in the register relevant to Trigger (D1000)
- ⑤ After the trigger is changed to '1' and writing from PLC to SS510E is complete, the trigger is changed to '0' and the process is complete.

4.8. Connection to KEYENCE PLC

4.8.1. Connection Diagram

- Next is an example of composition for programless communication with KEYENCE PLC.

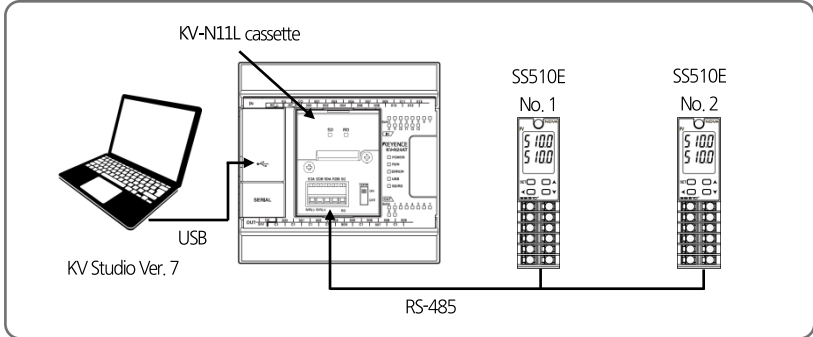

4.8.2. Communication Wiring

- Wire SS510E and KV-N11L Cassette as below.

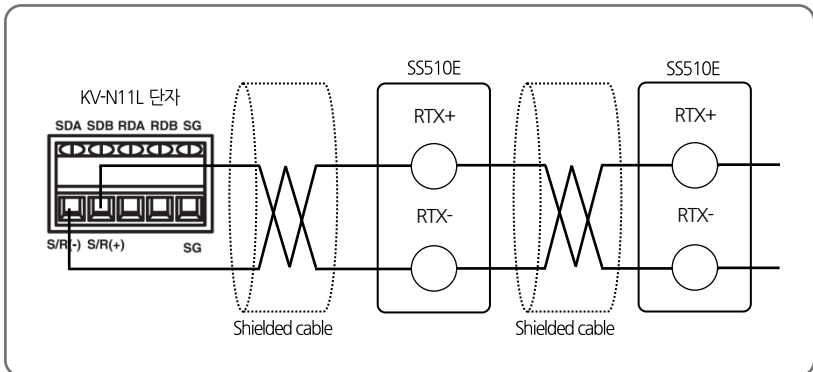

4.8.3. SS510E Setting

- Refer to 4.4.3 SS510E Setting

4.8.4. PLC Setting

- Communication module setting

- ① Connect PC and KV-N14DT and execute KV Studio
- ② Select 'Monitor/Simulator -> Setup communication -> Setup Communication' from menu
- ③ Select USB as communication method and click on 'OK'
- ③ Select 'Monitor/Simulator -> Read from PLC' from menu and click on 'Execute' on Read PLC window
- ④ After reading PLC, double click on 'Unit configuration -> KV-N14' on Workspace window
- ⑤ Set 'Extension cassette(port 1)' items in Unit Editor window as below. Click on 'Apply' and close window.

Item	Set Value	
Operation Mode	Modbus slave mode	-
Interface	RS-485(2 Wire - type)	-
Baud rate	38400	SS510E Default Value
Stop bit	1	SS510E Default Value
Parity	NONE	SS510E Default Value
Modbus slave station No. setting method	Unit editor	-
Modbus slave station No.	1	-

- ⑥ Select 'Monitor/Simulator -> Transfer to PLC' from menu and select 'Execute' Transfer PLC window.

4.8.5. Data Monitoring and Setting

- SS510E Data Monitoring

- ① Access PLC using KV Studio
- ② Select 'Monitor/Simulator -> Monitor Mode' from menu
- ④ Select 'Monitor/Simulator -> Batch monitor window' from menu and check data in Batch monitor window.

- Based upon default value of data map setting, the register area data are as follows.

ADDRESS.1	ADDRESS.2	ADDRESS.3	Parameter	Value
DM1000	DM1030	DM1060	Trigger	0
DM1001	DM1031	DM1061	Communication status flag	1, 0 repeat
DM1002	DM1032	DM1062	NPV	-
DM1021	DM1051	DM1081	ALBS	-

RO Area , RW Area

■ **SS510E Set Value Monitoring**

- ① Enter '2 (Read Set Value)' in the register relevant to Trigger Area (DM1000)
- ② After the trigger is changed to '2' and data writing is complete in RW area, the trigger is changed to '0' and the process is complete
- ③ Check the values in the uploaded RW Area(DM1015~DM1029)

■ **Changing ALBS through Writing SS510E Set Value**

- ① Enter set value '1' in the register relevant to ALBS(DM1021)
- ③ Enter '1 (Read Set Value)' in the register relevant to Trigger (DM1000)
- ⑤ After the trigger is changed to '1' and writing from PLC to SS510E is complete, the trigger is changed to '0' and the process is complete.

4.9. Connection to SIEMENS PLC

4.9.1. Connection Diagram

- Next is an example of composition for programless communication with SIEMENS PLC.

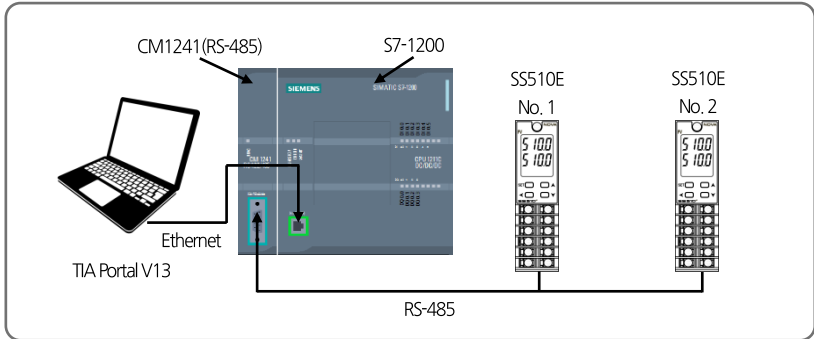

4.9.2. Communication Wiring

- Wire SS510E and CM1241 as below.

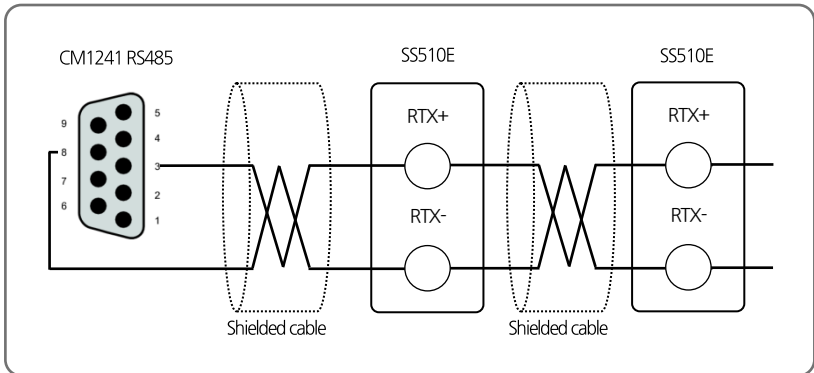

4.9.3. SS510E Setting

- Refer to 4.4.3 SS510E Setting

4.9.4. PLC Setting

■ CM1241 (RS-485) Module Setting

- ① Create Slave PLC Project
- ② Set Port Configuration of CM1241 (RS-485) from Device Configuration in Slave PLC.

Item	Set Value
Transmission rate	9.6kbps
Parity	Even parity
Data bits	8bit per character
Stop bits	1
Wait time	1

- ③ Check Hardware Identifier of CM1241.

■ Slave PLC Sample Logic Programming

- ① Create Global DB from sending and receiving data and enter parameters as below.

Item	Set Value
Name	MB_HOLD_REG
Data type	Struct
Offset	0.0
Retain	Checked
Accessible from HMI	Checked
Visible in HMI	Checked
Set point	Unchecked

- ② Call MB_COMM_LOAD from OB1 and enter parameters as below.

Item	Set Value
REQ	first scan(Address : %M1.0)
PORT	296(Check CM1241 Hardware Identifier)
BAUD	38400
PARITY	0
MB_DB	MB_SLAVE_DB
DONE	Tag_1(Address : %M200.0)
ERROR	Tag_2(Address : %M200.1)
STATUS	Tag_3(Address : %MW202)

③ Call MB_SLAVE from OB1 and enter parameters as below.

Item	Set Value
MB_ADDR	1
MB_HOLD_REG	P#DB3.DBX0.0WORD2000
NDR	-
DR	0
ERROR	MB_SLAVE_DB
STATUS	Tag_4(Address : %MW203)

4.9.5. Data Monitoring and Setting

■ S5510E Data Monitoring

- ① Connect to PLC using TIA Portal V13.
- ② 30 words are allocated in line with the order of S5510E connected to MB_HOLD_REG in MB_SLAVE_DB.

■ Based upon default value of data map setting, the register area data are as follows.

ADDRESS.1	ADDRESS.2	ADDRESS.3	Parameter	Value
DB1000	DB1030	DB1060	Trigger	0
DB1001	DB1031	DB1061	Communication status flag	1, 0 repeat
DB1002	DB1032	DB1062	NPV	-
DB1021	DB1051	DB1081	ALBS	-

RO Area , RW Area

■ S5510E Set Value Monitoring

- ① Enter '2 (Read Set Value)' in the register relevant to Trigger Area (DM1000)
- ② After the trigger is changed to '2' and data writing is complete in RW area, the trigger is changed to '0' and the process is complete
- ③ Check the values in the uploaded RW Area(DM1015~DM1029)

■ Changing ALBS through Writing S5510E Set Value

- ① Enter set value '1' in the register relevant to ALBS(DB1021)
- ③ Enter '1 (Read Set Value)' in the register relevant to Trigger (DB1000)
- ⑤ After the trigger is changed to '1' and writing from PLC to S5510E is complete, the trigger is changed to '0' and the process is complete.

5. Other Communication Function

5.1. Broadcast Mode

- Broadcast Mode sends the same command to all SS510Es connected to higher communication unit to carry out the same task.

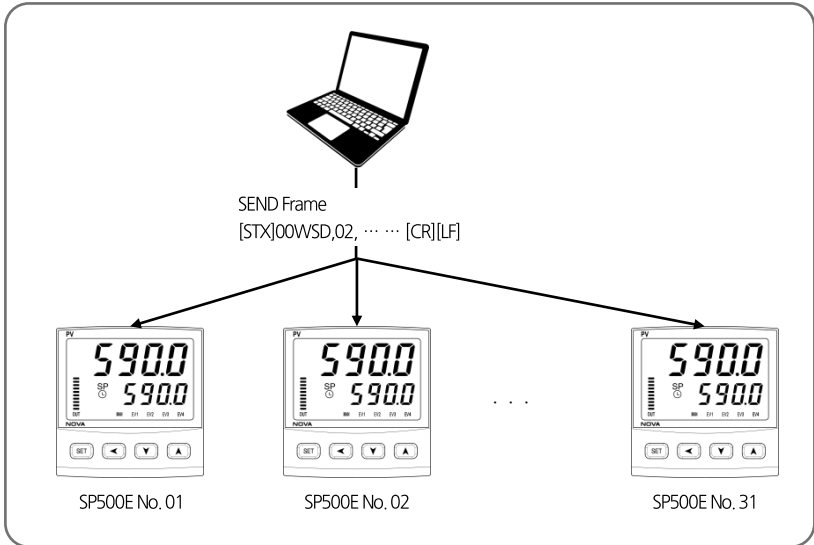

- **Broadcast Mode Communication Method**
 - To communicate with Broadcast Mode, set Frame Address to '00' and send



Only applies to Write-related commands.

- **Broadcast Mode Usable Protocols**
 - Only applicable to the following protocols : PC-LINK, PC-LINK+SUM, MODBUS-RTU and MODBUS-ASCII

5.2. Service Port

- Service port is a communication port for setting parameters and updating firmwares.
- You can check Micro-USB port by removing the 'Service Port' sticker as shown below.

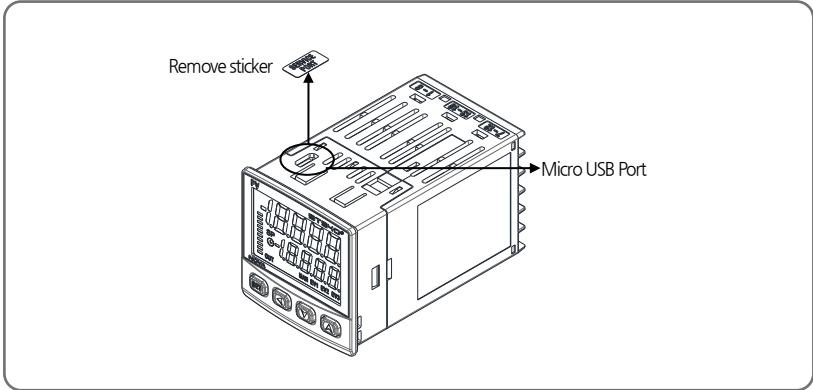

■ Service Port Specifications

Parameter	Set Value
Protocol	PCC1(PC-LINK+SUM)
Transmission speed	38400bps
Stop bit	1
Parity bit	NONE
Data length	8
Communication address	1

- The Service Port requires a Micro-USB cable and a converter that are sold separately.

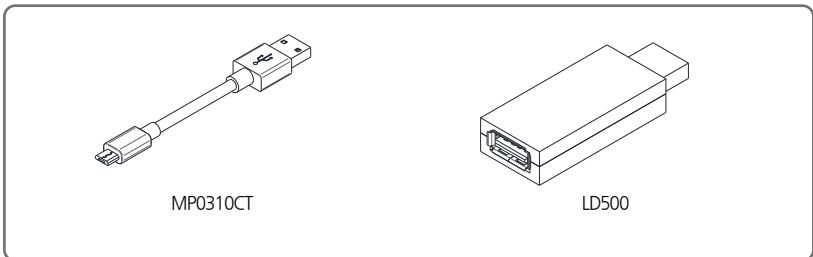

6. Register Guide

- D-Register is a group of data that can check the all status of SS510E through communication.
- They are in groups of 100 according to their contents as the following.

D-Register Range	Group Name	Description	Read	Write
D0001~D0099	PROCESS	Basic operation info display D-Register group	○	◆
D0100~D0299	FUNCTION	Operation setting D-Register group	○	○
D0600~D0699	IN/OUT	Input/control & trans output setting D-Register group	○	△
D0700~D0799	PLC/NPL	PLC setting D-Register group	○	△

- ○ : Able to read or write in all parameters within applicable range.
- △ : Able to partially read or write within applicable range.
- ◆ : Unable to write in all parameters within applicable range.

6.1. PROCESS

- PROCESS Group stores basic data generated during operation. Of the data includes Bit Map which displays various states in bit as the following.

- Status Information D-Register

D-Reg.	Symbol	Description
D0001	NPV	Current measured value
D0019	ERROR	Current set value
D0022	PV.LO	PV lower limit value
D0023	PV.HI	PV upper limit value

- Status Information Register Bit Map Information

BIT	ERROR STATUS
	D0019
0	
1	
2	
3	
4	
5	
6	
7	
8	+OVER
9	-OVER
10	S.OPN
11	
12	
13	
14	
15	

6.2. FUNCTION GROUP

- FUNCTION Group is composed of D-Registers pertinent to operation and function setting.

D-Reg.	Symbol	Description
D0135	US1	User screen registration 1
D0136	US2	User screen registration 2
D0137	LOCK	Set key lock
D0139	DSP.H	Set upper limits of sensor input values
D0140	DSP.L	Set lower limits of sensor input values

6.3. IN/OUT GROUP

- IN/OUT Group is composed of D-Register for setting input and control output.

D-Reg.	Symbol	Description
D0601	IN-T	Set sensor type
D0602	IN-U	Set sensor unit
D0603, D0604	IN.RH, IN.RL	Set upper/lower limits of input range
D0605	IN.DP	Set decimal place
D0606, D0607	IN.SH, IN.SL	Set upper/lower limits of input scale
D0608	IN.FL	Set measurement value filter
D0609	B.SL	Select Burn-Out
D0610	R.SL	Select reference contact compensation function
D0611 ~ D0613	BS.P1 ~ BS.P3	Set piece bias 1~3 to set bias values
D0615	BS0	Set bias for IN.RL
D0616 ~ D0618	BS1 ~ BS3	Set piece bias 1~3 to set bias ranges
D0619	BS4	Set bias for IN.RH
D0621	AL.BS	Set offset for all bias
D0622	D.FL	Select filter function for measured values
D0652	RT1.H	Set transmission output 1 upper limits
D0653	RT1.L	Set transmission output 1 lower limits
D0658	RT2.H	Set transmission output 2 upper limits
D0659	RT2.L	Set transmission output 2 lower limits

6.4. COMM GROUP

- COMM Group is composed of D-Registers for setting communication and checking current set values.

D-Reg.	Symbol	Description
D0661	COM.P	Set communication protocol
D0662	BAUD	Set communication speed
D0663	PRTY	Set parity bit
D0664	S.BIT	Set stop bit
D0665	D.LEN	Set data length
D0666	ADDR	Set communication address
D0667	RP.TM	Set response time
D0668	RBS	Set value added to SLAVE during cooperative operation
D0673	COM.P	Read communication protocol
D0674	BAUD	Read communication speed
D0675	PRTY	Read parity bit
D0676	S.BIT	Read stop bit
D0677	D.LEN	Read data length
D0678	ADDR	Read communication address
D0679	RP.TM	Read response time

6.5. PLC GROUP

- PLC Group is composed of D-Register to set programless communication.

D-Reg.	Symbol	Description
D0710	SW.TM	Set send delay time
D0711	RW.TM	Set receive wait time
D0712	MU.NO	Set max number of connection
D0713	R.TYP	Set register type
D0714	S.ADR	Set start address
D0715	MAP.S	Set Data map
D0716~D0728	RO.01~RO.13	Set read area address 1 ~13
D0729~D0743	RW.01~RW.15	Set read / write area address 1 ~15

6.9. NPL GROUP

- NPL Group is composed of D-Register that can check the current set value used during Programless Communication

D-Reg.	Signs	Description
D0751	N.SWT	Send delay time
D0752	N.RWT	receive waiting time
D0754	N.RTY	Register type
D0755	N.SAD	Start address
D0757~D0769	N.001~N.013	Read area address 1 ~ 13
D0770~D0784	N.W01~N.W15	Read/write area address 1~15

6.9. D-Register Table

D-Reg.	PROCESS	FUNCTION	SET POINT	SIGNAL	ALARM	PID	IN/OUT	PLC
	0	100	200	300	400	500	600	700
0								
1	NPV						IN.T	
2							IN.U	
3							IN.RH	
4							IN.RL	
5							IN.DP	
6							IN.SH	
7							IN.SL	
8							IN.FL	
9							B.SL	
10							R.SL	SW.TM
11							BS.P1	RW.TM
12							BS.P2	MU.NO
13							BS.P3	R.TYPE
14								S.ADR
15							B50	MAP.S
16							B51	RO.01
17							B52	RO.02
18							B53	RO.03
19	ERROR						B54	RO.04
20								RO.05
21							AL.B5	RO.06
22	PV.LO						D.FL	RO.07
23	PV.HI							RO.08
24								RO.09
25								RO.10
26								RO.11
27								RO.12
28								RO.13
29								RW.01
30								RW.02
31								RW.03
32								RW.04
33								RW.05
34								RW.06
35		US1						RW.07
36		US2						RW.08
37		LOCK						RW.09
38								RW.10
39		DSP.H						RW.12
40		DSP.L						RW.13
41								RW.14
42								RW.15
43								
44								
45								
46								
47								
48								
49								

D-Reg.	PROCESS	FUNCTION	SET POINT	SIGNAL	ALARM	PID	IN/OUT	PLC
	0	100	200	300	400	500	600	700
50								
51								N.SWT
52							RT1.H	N.RWT
53							RT1.L	
54								N.RTY
55								N.SAD
56								
57								N.001
58							RT1.H	N.002
59							RT1.L	N.003
60								N.004
61							COM.P	N.005
62							BAUD	N.006
63							PRTY	N.007
64							S.BIT	N.008
65							D.LEN	N.009
66							ADDR	N.010
67							RP.TM	N.011
68							RBS	N.012
69								N.013
70								N.W01
71								N.W02
72								N.W03
73							COM.P	N.W04
74							BAUD	N.W05
75							PRTY	N.W06
76							S.BIT	N.W07
77							D.LEN	N.W08
78							ADDR	N.W09
79							RP.TM	N.W010
80								N.W011
81								N.W012
82								N.W013
83								N.W014
84								N.W015
85								
86								
87								
88								
89								
90								
91								
92								
93								
94								
95								
96								
97								
98								
99								